

# MAINTENANCE MANUAL

# 9303

TRUE RMS RF LEVEL METER

# RACAL-DANA

**RACAL**

*The Electronics Group*

TRUE RMS RF LEVEL METER 9303

The changes listed below have been made to some instruments having serial numbers above 1500.

Changes found to apply to the instrument with which this manual is to be used should be incorporated in the manual by manuscript amendment.

PAGE 1-7

Accessories Provided. Fuse for 100/120V Delete '23-0052'  
Insert '23-0022'.

PAGE 3-1

Paragraph 3.2.2.1 Delete '1/4in x 1 1/4in', '23-0052' and '23-0056'  
Insert '5mm x 20mm', '23-0022' and '23-0031'.

PAGE 4-6

Paragraph 4.2.3. Line fuse Delete '1/4in x 1 1/4in'  
Insert '5mm x 20mm'.

PARTS LIST 1

FS2 Delete '23-0052' Insert '23-0022'  
Delete '23-0056' Insert '23-0031'

AC Power Plug Delete '23-3294' Insert '23-3420'.

PUBLICATION NUMBER TH 3174  
ISSUE 4.7.84

---

# 9303

TRUE RMS RF LEVEL METER

## **RACAL-DANA**

### **RACAL-DANA INSTRUMENTS INC.**

4 Goodyear Street, PO Box C 19541, Irvine, Ca 92713, USA.  
Telephone: (714) 859-8999. TWX: 910-595-1136, TLX: 678-341

### **RACAL-DANA INSTRUMENTS LTD.**

Duke Street, Windsor, Berkshire SL4 1SB, United Kingdom  
Telephone: Windsor (07535) 68101, TLX: 847013

### **RACAL-DANA INSTRUMENTS S.A.**

18 Avenue Dutartre, 78150 Le Chesnay, France  
Telephone: (3) 955-8888, TLX: 697 215

### **RACAL-DANA INSTRUMENTS GmbH**

Hermannstrasse 29, D-6078 Neu Isenburg, Federal Republic of Germany  
Telephone: 06102-2861/2, TLX: 412896

### **RACAL-DANA INSTRUMENTS ITALIA SRL**

20161 Milano, Via Angeloni 8, Italy  
Telephone: (02) 6459558/6468189 TLX: 315697

The logo for RACAL, consisting of the word "RACAL" in a bold, italicized, sans-serif font. Each letter is contained within a thick, black rectangular border, giving it a three-dimensional or blocky appearance.

---

**PUBLICATION DATE: NOVEMBER 1982**

Copyright ©1982 by Racal-Dana Instruments Ltd. Printed in England. All rights reserved.  
This book or parts thereof may not be reproduced in any form without written permission of the publishers.

TRUE RMS RF LEVEL METER 9303

The changes listed below have been made to some instruments having serial numbers above 1350.

Changes found to apply to the instrument with which this manual is to be used should be incorporated in the manual by manuscript amendment.

PARTS LIST 22

R126        Delete '5.6k' and '20-2562'  
              Insert '100' and '20-2101'

FIG 11

R126        Change value to 100.

TOXIC HAZARD

LITHIUM BATTERIES

THIS EQUIPMENT CONTAINS LITHIUM BATTERIES

1. Lithium batteries are dangerous only if the case is broken. Breakage may occur due to internal pressure as well as the application of external force. The following precautions should be strictly observed:-
  - (1) Do not attempt to recharge the battery.
  - (2) Do not short circuit the battery. Follow the instructions given regarding the order of terminal disconnection and reconnection when changing the battery.
  - (3) Do not attempt to solder connections to the battery body. When soldering connections to the connecting strips, maintain the heat required for the minimum possible time.
  - (4) Do not attempt to open the battery.
  - (5) Do not dispose of discharged batteries in normal waste containers whose contents may be incinerated.
2. If exposure to fumes or material from a damaged battery occurs, medical treatment should be sought as soon as possible.

TRUE RMS RF LEVEL METER 9303

The changes listed below have been made to some instruments having serial numbers above 1200.

Changes found to apply to the instrument with which this manual is to be used should be incorporated in the manual by manuscript amendment.

FIG.11

PARTS LISTS 23 AND 25

In some units a 74LS629, Racal-Dana part number 22-4688, is fitted in position IC15. When this is the case a 1820p +1% silver mica capacitor, Racal-Dana part number 21-2925 must be fitted in position C60. AR5155

PARTS LIST 17

Diodes	D2	Delete 'Not Used' Insert 'Voltage Regulator (BZX79C10) 22-1815'	AR5384
--------	----	--	--------

FIG.9

1C46 Add D2 as shown

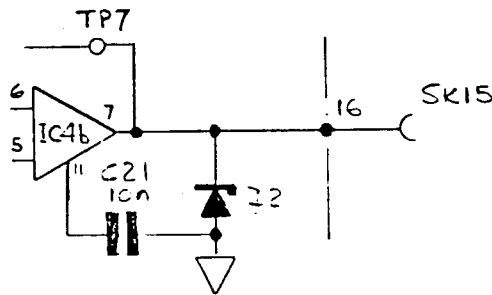

### 'POZIDRIV' SCREWS

The metric thread cross-head screws fitted to RACAL equipment are of the 'Pozidriv' type. Phillips and 'Pozidriv' screwdrivers are not interchangeable, and use of the wrong type of screwdriver may cause damage. POZIDRIV is a registered trade mark of G.K.N. Screws and Fasteners Ltd. 'Pozidriv' screwdrivers are manufactured by Stanley Tools Ltd.

### MOS ELECTRONIC DEVICES

This unit contains MOS devices, and care should be taken to avoid static discharge damage.

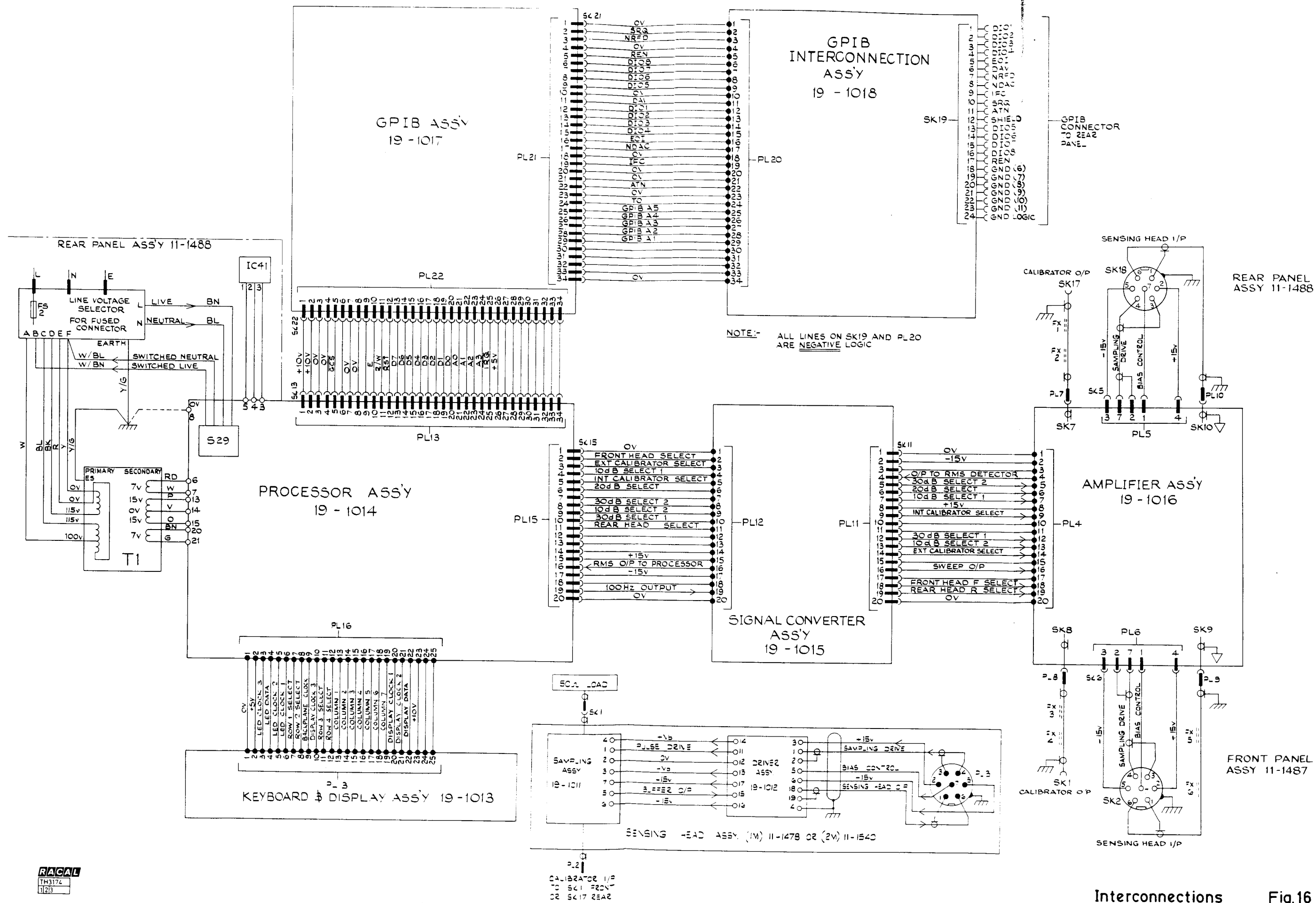

**RACAL**  
 TH3174  
 1123

2.2  
 CALIBRATOR I/P  
 SK1 REAR  
 SK17 REAR

Interconnections Fig.16



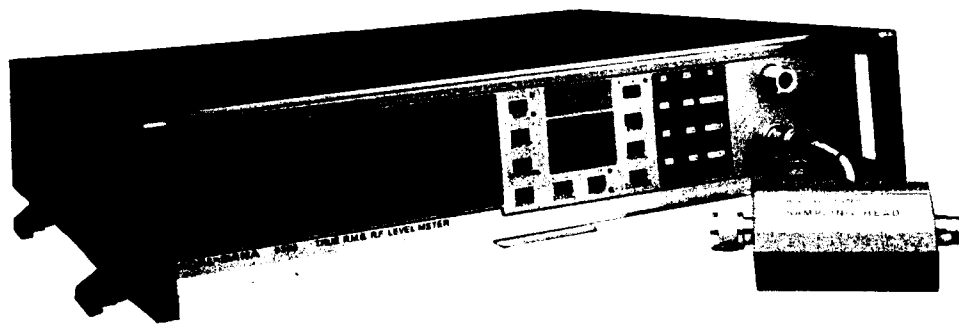

True R.M.S. R.F. Level Meter 9303

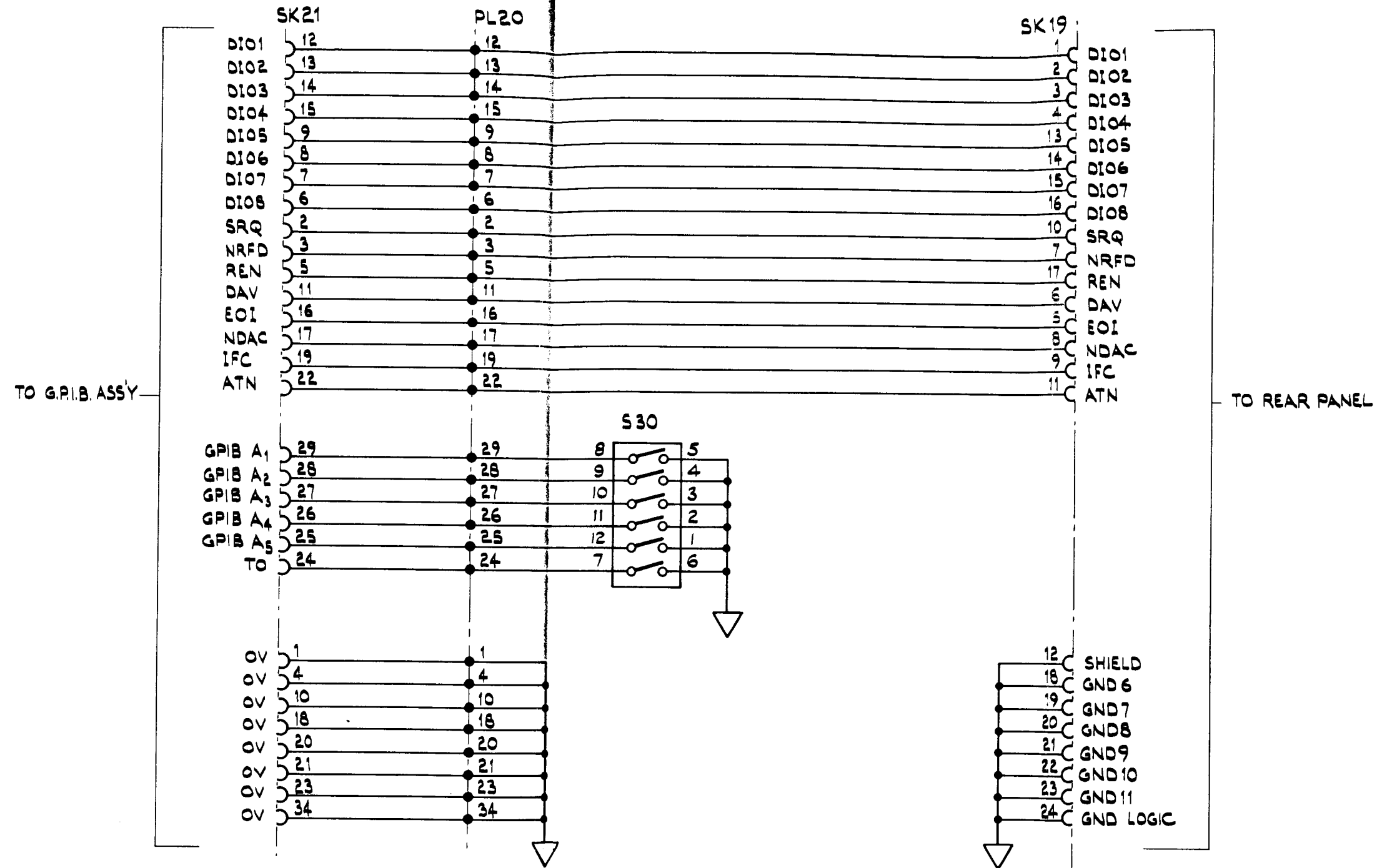

Circuit Diagram: GPIB  
Connector Assembly 19-1018

Fig.15

# TABLE OF CONTENTS

---

Section	Title	Page
1	<b>TECHNICAL SPECIFICATION</b>	<b>1-1</b>
1.1	Specification	1-1
2	<b>GENERAL DESCRIPTION</b>	<b>2-1</b>
2.1	Introduction	2-1
2.2	Measuring Head	2-1
2.3	Reduction of Display Jitter	2-2
2.4	Noise Cancellation	2-2
2.5	Measurement Principles	2-2
2.6	Storage of Front Panel Settings	2-3
2.7	GPIB Interface	2-3
2.8	Maintenance	2-3
3	<b>PREPARATION FOR USE</b>	<b>3-1</b>
3.1	Introduction	3-1
3.2	Power Supply	3-1
3.2.1	AC Voltage Range Setting	3-1
3.2.2.	Line Fuse	3-1
3.2.3	DC Fuse	3-2
3.2.4	Power Lead	3-2
3.3	Connection of Measuring Heads	3-2
3.4	Fitting the Fixed Rack Mounting Kit 11-1496	3-3
3.5	Removal and Replacement of the Covers	3-4
3.6	Preparation for Use With the GPIB	3-4
3.6.1	Interface Connector	3-4
3.6.2	Address Setting	3-5
4	<b>OPERATING INSTRUCTIONS</b>	<b>4-1</b>
4.1	Introduction	4-1
4.2	Description of Controls, Indicators and Connectors	4-1
4.2.2	Front Panel Items	4-1
4.2.3	Rear Panel Items	4-5
4.3	Switching On	4-8
4.4	Measuring Head Calibration	4-8
4.4.1	The FACTORY ECAL	4-8
4.4.1.2	Using the CALIBRATOR Sockets	4-9
4.4.1.3	Using an External Calibration Source	4-9
4.4.2	The USER ECAL	4-10
4.4.2.3	Using the CALIBRATOR Sockets	4-10
4.4.2.4	Using an External Calibration Source	4-11
4.4.2.5	USER ECAL Factor Enablement	4-11
4.5	Measuring Head Attachments	4-11
4.5.1	50 $\Omega$ Attenuators	4-11
4.5.2	Signal Amplifiers	4-12
4.5.3	High Impedance Probes	4-12
4.5.4	Low Impedance Probes	4-13

# TABLE OF CONTENTS (Continued)

Section	Title	Page
4.6	Display of ECAL Factors	4-13
4.7	Frequency Response	4-13
4.8	Setting of Averaging Time	4-14
4.9	Continuous Averaging Mode	4-15
4.10	Ranging Mode Setting	4-15
4.11	Voltage Primary Measurement Function	4-16
4.12	Power Primary Measurement Function	4-16
4.13	Ratio Measurements	4-17
4.14	Percentage Difference Measurements	4-18
4.15	Null Measurements	4-19
4.16	dB Measurements	4-19
4.17	Analogue Display	4-20
4.18	Storage of Front Panel Settings	4-20
4.19	Special Functions	4-21
4.20	Error Codes	4-21
4.21	Control Via the GPIB	4-24
4.22	Remote/Local Changeover	4-24
4.22.1	Local to Remote Changeover	4-24
4.22.2	Remote to Local Changeover	4-24
4.22.3	Local Lockout	4-25
4.23	Command Codes for Addressed Mode Operation	4-25
4.24	Entry of Numerical Values	4-34
4.25	Output Message Format	4-35
4.26	Status Byte Format	4-36
4.27	Service Request (SRQ) Output	4-36
4.28	Logic Levels	4-36
<b>5</b>	<b>PRINCIPLES OF OPERATION</b>	<b>5-1</b>
5.1	Introduction	5-1
5.2	Principles of Operation	5-1
5.2.1	Functional Systems	5-1
5.2.2	The Sampling System	5-1
5.2.3	The Analogue Processing System	5-2
5.2.4	The Microprocessor System	5-2
5.2.4.3	Digital Signal Processing	5-3
5.2.4.4	Instrument Control	5-3
5.2.5	The Keyboard/Display System	5-3
5.2.6	The Calibrator System	5-4
5.2.7	The GPIB Interface	5-4
5.3	Technical Description	5-7
5.3.1	The Sampling System	5-7
5.3.1.2	10 Hz Triangular Waveform Generation	5-7
5.3.1.3	Voltage Controlled Oscillator	5-7
5.3.1.4	Sampling Pulse Generation	5-8
5.3.1.5	Sampling Bridge Operation	5-8
5.3.1.6	Pulse Amplification	5-8
5.3.1.7	Bias Control Circuit	5-9
5.3.2	Analogue Signal Processing System	5-9
5.3.2.2	Input Multiplexer	5-9
5.3.2.3	Switched Gain Amplifier	5-9
5.3.2.4	Second Sampler	5-10

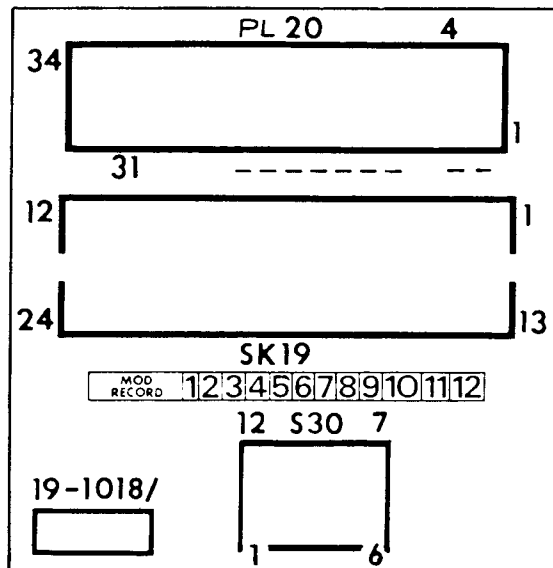

Component Layout :  
GPIB Connector Assembly 19-1018

Fig.14

# TABLE OF CONTENTS (Continued)

Section	Title	Page
5.3.2.5	True RMS Detector	5-12
5.3.2.6	Output Sample and Hold	5-16
5.3.2.7	Auto-Zeroing	5-16
5.3.2.8	Prevention of Lock Up	5-17
5.3.3	The Microprocessor System	5-17
5.3.3.4	Analogue to Digital Conversion	5-18
5.3.3.5	Digital Data Input	5-19
5.3.3.6	Digital Data Processing	5-19
5.3.3.7	Serial Data Output to Display	5-19
5.3.3.8	Parallel Data Output to the GPIB Interface	5-19
5.3.3.9	Data Input from the GPIB Interface	5-19
5.3.3.10	Data Input from the Keyboard	5-20
5.3.3.11	Attenuator, Measuring Head and Calibrator Control	5-20
5.3.3.12	The Chip Select Circuit	5-21
5.3.3.13	Reset and Memory Supply Changeover Circuit	5-21
5.3.3.14	Test Switch Bank S30	5-22
5.3.4	The Keyboard/Display System	5-22
5.3.4.3	The Keyboard	5-22
5.3.4.4	The Liquid Crystal Display	5-22
5.3.4.5	The LED Indicators	5-23
5.3.5	The Calibrator System	5-23
5.3.5.2	The Internal Calibrator	5-23
5.3.5.3	The External Calibrator	5-24
5.3.6	The GPIB Interface	5-24
5.3.6.2	Address Setting and Recognition	5-24
5.3.6.3	Operation as a Listener	5-24
5.3.6.4	Operation as a Talker	5-25
5.3.6.5	Detection of the Serial Poll Disable Message	5-26
APPENDIX 1	Analysis of RMS Measuring Circuit	5-27
APPENDIX 2	Operation of Linearised Transconductance Multiplier	5-29
<b>6</b>	<b>MAINTENANCE</b>	<b>6-1</b>
6.1	Introduction	6-1
6.2	General Maintenance Information	6-1
6.2.1	Repair and Calibration of the Measuring Head	6-1
6.2.2	Battery Replacement	6-1
6.2.3	Special Functions for Maintenance Purposes	6-3
6.2.4	Test Switches	6-4
6.3	Fault Finding on Assemblies 19-1014 and 19-1017	6-4
6.3.1	Introduction	6-4
6.3.2	Assembly 19-1014	6-4
6.3.3	Assembly 19-1017	6-4
6.4	Signature Analysis	6-8
6.4.1	Preparation for Signature Analysis	6-8
6.4.2	Connection of the Signature Analyser	6-8
6.4.3	Analysis Procedure	6-8
6.5	Calibration Procedure	6-12
6.5.1	Introduction	6-12
6.5.2	Test Equipment Required	6-12
6.5.3	Temperature During Calibration	6-12
6.5.4	Signal Source Level Setting	6-12
6.5.5	Additional Measuring Head	6-12



FROM PROCESSOR ASSY.

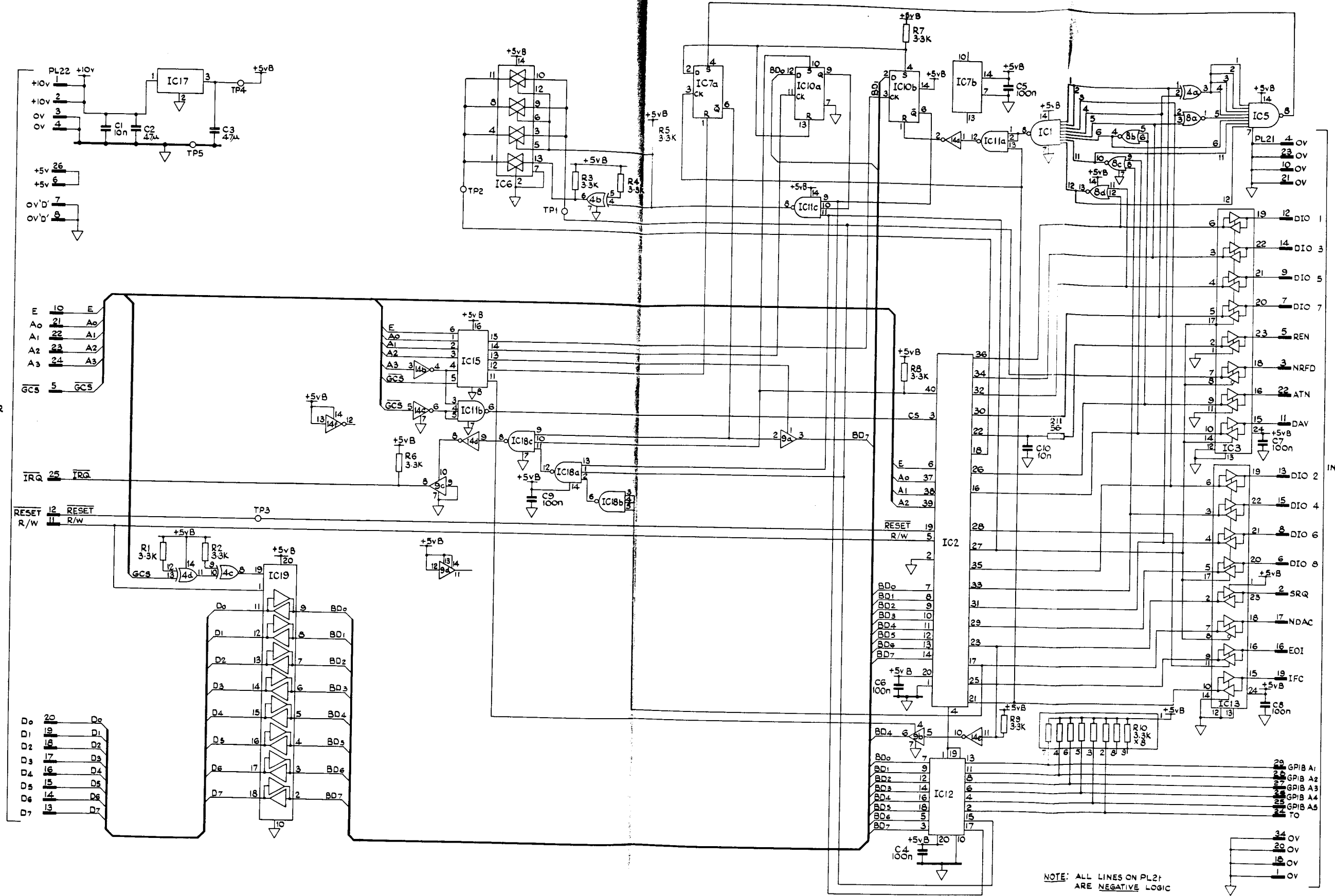

TO GPI.B. INTERCONNECT ASSY.



Circuit Diagram:  
GPIB Assembly 19-1017

Fig. 13



# LIST OF ILLUSTRATIONS

---

Figure	Title	Page
1.1	Input Waveform Crest Factor Limits	1-5
3.1	Fitting the Fixed Rack Mounting Kit	3-3
4.1	Front Panel Layout	4-7
4.2	Rear Panel Layout	4-7
5.1	Block Diagram	5-5
5.2	Idealised Waveforms: Sampling and Signal Processing	5-11
5.3	Feedback Loop Operation	5-13
5.4	Multiplier	5-14
5.5	Feedback Switching	5-15
5.6	Comparator Waveforms	5-16
5.7	Feedback Loop	5-27
5.8	Multiplier Operation	5-29
6.1	Input Socket (Viewed from the front)	6-16
6.2	Bias Balance Waveforms	6-19
6.3	Connections for VSWR Check	6-29
6.4	Fitting the Liquid Crystal Display	6-34
6.5	Calibrator Socket Mounting	6-35

# LIST OF TABLES

---

Table	Title	Page
1.1	Technical Specification	1-1
3.1	GPIB Connector Pin Assignment	3-4
3.2	Address Switch Settings	3-6
4.1	Special Functions	4-22
4.2	Error Codes	4-23
4.3	Permitted Terminating Groups	4-25
4.4	Primary Measurements Function Commands	4-26
4.5	Ω Store Commands	4-26
4.6	Compute Function Commands	4-27
4.7	Range Commands	4-28
4.8	Head Selection Commands	4-28
4.9	Calibrator Control Commands	4-29
4.10	Control Setting Storage Commands	4-29
4.11	Control Setting Recall Commands	4-29
4.12	Calibrate Commands	4-30
4.13	Calibration Factor Commands	4-30
4.14	Interrupt Commands	4-31
4.15	Measurement Averaging Mode and Timing Selection Commands	4-32
4.16	Trigger Commands	4-33
4.17	Cancellation Commands	4-34
4.18	Numerical Input Format	4-34
4.19	Stored Value Units	4-35
4.20	Interface Output Message Format	4-35
4.21	Status Byte	4-36
6.1	Additional Special Functions	6-3
6.2	Test Switch Functions	6-4
6.3	Fault Finding Procedure Assembly 19-1014	6-5
6.4	Fault Finding Procedure Assembly 19-1017	6-6
6.5	System Signatures for Assembly 19-1014	6-9
6.6	System Signatures for Assembly 19-1017	6-10
6.7	Integrated Circuit Locations	6-11
6.8	Test Equipment Required for Calibration	6-13
6.9	Power Input Resistance	6-14
6.10	Integrated Circuit Locations	6-15
6.11	Voltage Regulation Test Limits	6-17
6.12	Switching Level	6-17
6.13	Linearity Check	6-25
6.14	Accuracy Check	6-26
6.15	Frequency Response Check Points	6-28
6.16	Frequency Response Check Points	6-28
6.17	VSWR Return Loss	6-30

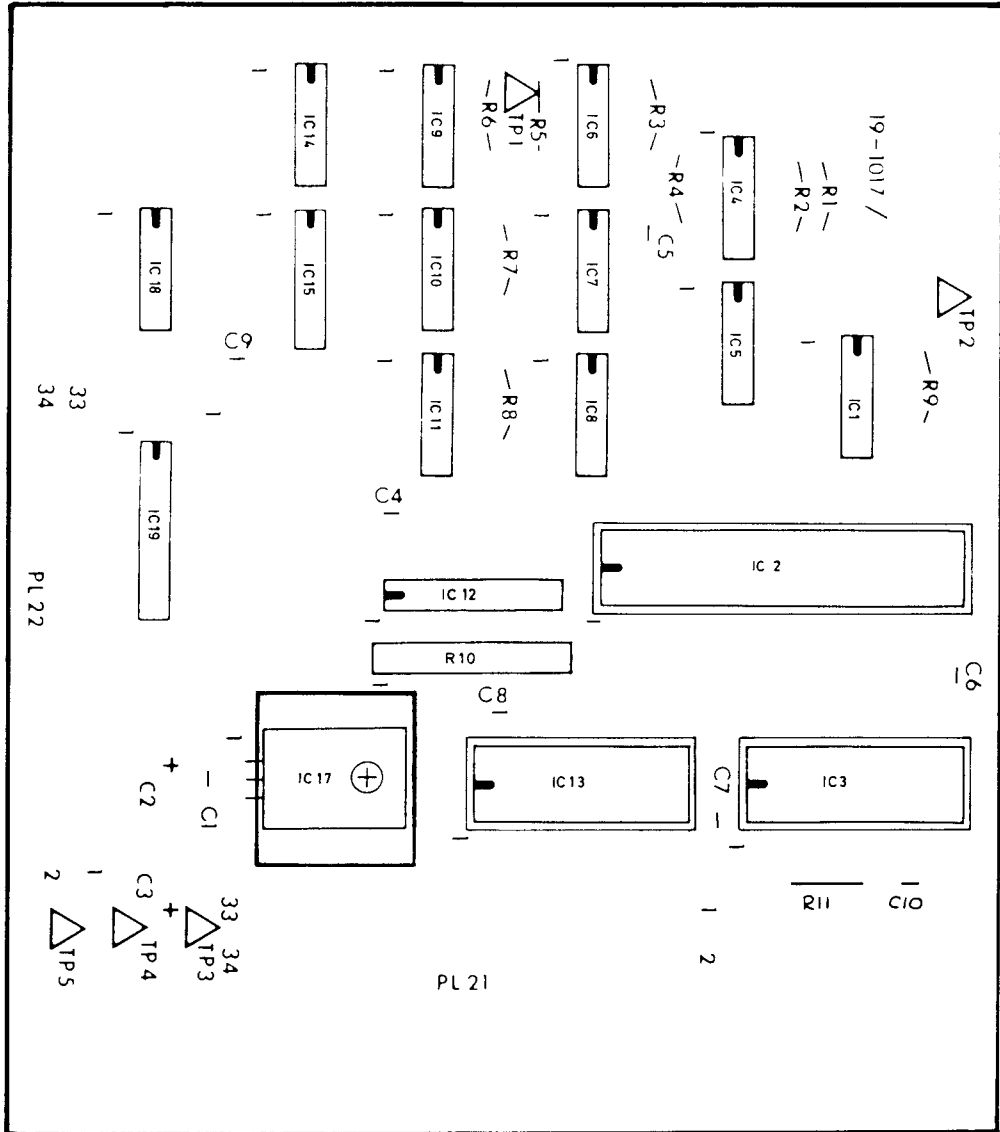

Component Layout:  
GPIB Assembly 19-1017

Fig.12

## 1.1 SPECIFICATION

1.1.1 The published specification for the Racal-Dana True RMS RF Level Meter Model 9303 is given in Table 1.1.

TABLE 1.1

Technical Specification

OPERATIONAL MODES	
Measurement Functions:	<p>The 9303 measures true RMS voltage. This measurement may be displayed in voltage units, or converted, using a number of stored parameters, to provide a display of:</p> <ol style="list-style-type: none"><li>(1) The ratio of the measured voltage to a stored voltage level. This may be displayed as a numeric ratio, or in dB.</li><li>(2) The difference between the measured voltage and a stored voltage level.</li><li>(3) The difference as in (2) expressed as a percentage of the stored voltage level.</li><li>(4) True power, computed as <math>V^2/R</math>, where R is a stored resistance value.</li><li>(5) The ratio of the computed power to a stored power level. This may be displayed as a numeric ratio, or in dB. When the display is in the dB and the stored power level is 1 mW, the display units annunciator indicates dBm.</li><li>(6) The difference between the computed power and a stored power level.</li><li>(7) The difference as in (6) expressed as a percentage of the stored power level.</li></ol>

TABLE 1.1 (Continued)  
Technical Specification

ELECTRICAL CHARACTERISTICS	
Frequency Range:	10 kHz to 2 GHz.
Voltage Range:	<p>30 <math>\mu</math>V to 3.162 V r.m.s. over the frequency range from 10 kHz to 700 MHz.            30 <math>\mu</math>V to 1 V r.m.s. over the frequency range from 700 MHz to 2 GHz.            The instrument operates in nine voltage ranges having full scale readings of</p> <p style="margin-left: 40px;">316.2 <math>\mu</math>V            1 mV            3.162 mV            10 mV            31.62 mV            100 mV            316.2 mV            1 V            3.162 V</p>
True Power Range:	<p>In a 50 <math>\Omega</math> system:            20 pW to 200 mW over the frequency range from 10 kHz to 700 MHz.            20 pW to 20 mW over the frequency range from 700 MHz to 2 GHz.</p>
dBm Range:	<p>In a 50 <math>\Omega</math> system:            -77 dBm to +23 dBm.</p>
Input Impedance:	<p>With the measuring head terminated by the matched load supplied:            50 <math>\Omega</math> nominal.            Unterminated measuring head (at low frequencies):            Approximately 100 k<math>\Omega</math> in parallel with 20 pF.</p>
Input VSWR:	<p>With the measuring head terminated by the matched load supplied:            Better than 1.1 up to 1 GHz.            Better than 1.5 at 2 GHz.</p>

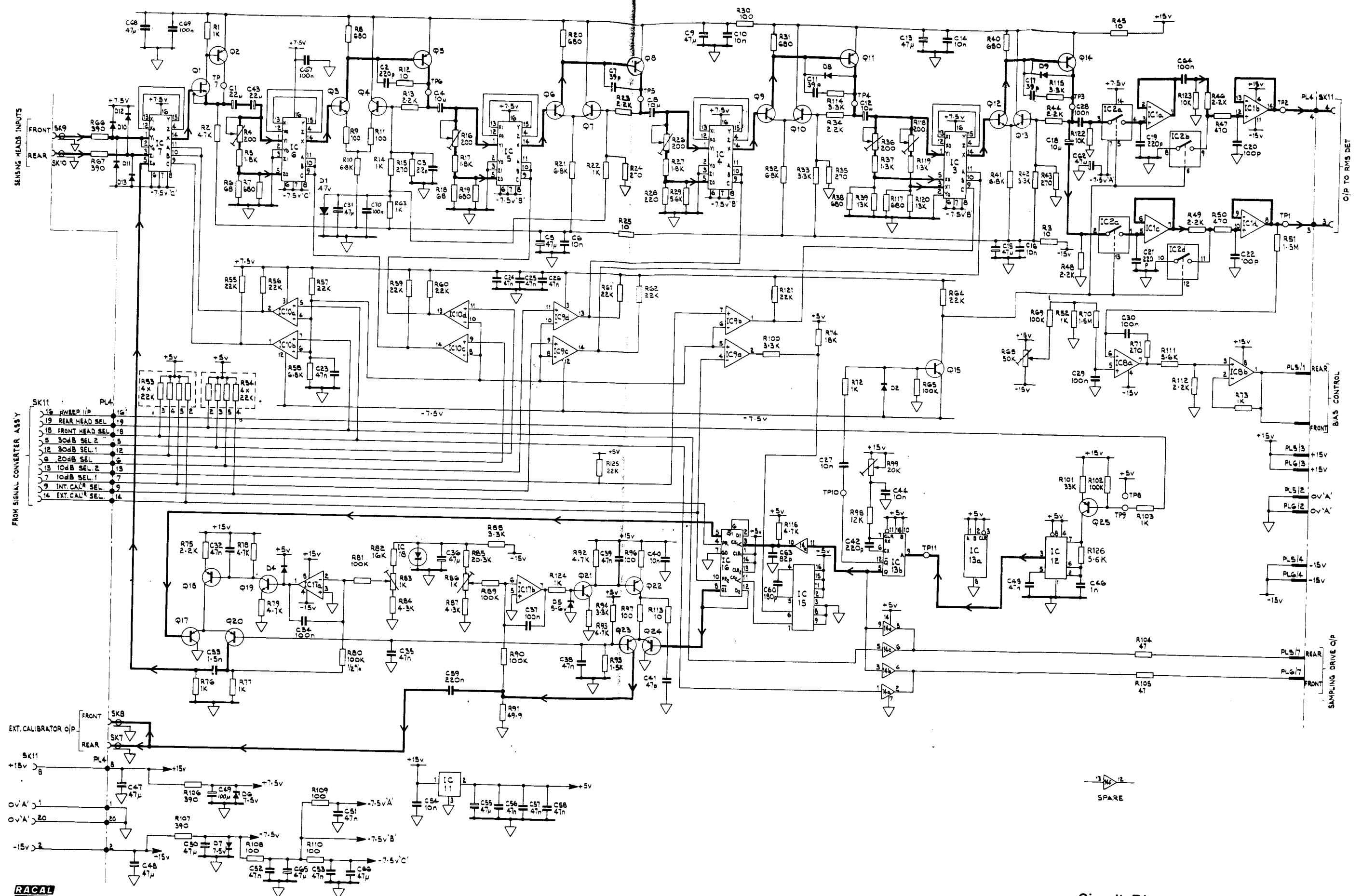

**RACAL**  
 TH3174  
 2

Circuit Diagram: **Fig.11**  
 Amplifier Assembly 19-1016

TABLE 1.1 (continued)

Technical Specification

ELECTRICAL CHARACTERISTICS (continued)	
Measurement Accuracy:	<p>The measurement accuracy, relative to the measuring head frequency response curve, for voltage measurements is given in the table which follows. The following points should be noted:</p> <ol style="list-style-type: none"> <li>(1) The quoted accuracy for the temperature ranges from 0°C to +18°C and from +28°C to +55°C will only be obtained if a USER ECAL factor, measured using the 9303 calibrator at a temperature within ±5°C of the operating temperature, is used.</li> <li>(2) The accuracy will be maintained for the quoted period from the date of FACTORY ECAL prior to despatch, or from the date of a FACTORY ECAL performed by the customer using the 9303 calibrator.</li> </ol>

PERIOD	RANGE	+18°C to +28°C			0°C to 18°C and +28°C to +55°C		
		AT CAL. FREQ.	10kHz to 500 MHz	500 MHz to 2 GHz	AT CAL. FREQ.	10kHz to 500 MHz	500 MHz to 2 GHz
6 MONTHS	3.162 V and 316.2 μV	2.0 + 0.1	3.5 + 0.1	6.0 + 0.1	2.5 + 0.2	5.0 + 0.2	8.0 + 0.2
	1 mV to 1 V	1.0 + 0.1	2.5 + 0.1	5.0 + 0.1	1.5 + 0.2	4.0 + 0.2	7.0 + 0.2
12 MONTHS	3.162 V and 316.2 μV	2.25 + 0.1	3.75 + 0.1	6.25 + 0.1	2.75 + 0.2	5.25 + 0.2	8.25 + 0.2
	1 mV to 1 V	1.25 + 0.1	2.75 + 0.1	5.25 + 0.1	1.75 + 0.2	4.25 + 0.2	7.25 + 0.2
				$e = 20 \times 10^{-6}$		$e = 30 \times 10^{-6}$	

VOLTAGE MEASUREMENT ACCURACY  
(% OF READING + % OF RANGE)

The error (in voltage units) in the measurement obtained will not exceed the figure calculated from:

$$\text{Maximum Error} = \pm \left( \frac{M \times \%M}{100} + \frac{R \times \%R}{100} + \sqrt{M^2 + e^2} - M \right)$$

Where M is the measurement indication obtained, in volts  
 %M is the % of measurement figure from the table  
 R is the full scale value of the range in use, in volts  
 %R is the % of range figure from the table  
 e is the offset error from the table

Since e is added in RSS fashion it has greatest effect when the measured value is low.

### Worked Example

Consider measurements being made at a temperature within the range from +18°C to +28°C, within six months of a FACTORY ECAL.

Suppose the measurement indication is 400 μV, using the 1 mV range, and the signal frequency is 500 kHz (calibration frequency).

From the table: %M = 1.0  
 %R = 0.1  
 e = 20 × 10<sup>-6</sup>

The error will not exceed

$$\begin{aligned} & \pm \left( \frac{400 \times 10^{-6} \times 1}{100} + \frac{1 \times 10^{-3} \times 0.1}{100} + \sqrt{16 \times 10^4 \times 10^{-12} + 4 \times 10^2 \times 10^{-12}} - 400 \times 10^{-6} \right) \\ & = \pm \left( 4 \times 10^{-6} + 1 \times 10^{-6} + \sqrt{160400 \times 10^{-12}} - 400 \times 10^{-6} \right) \\ & = \pm \left( 4 \times 10^{-6} + 1 \times 10^{-6} + 400.5 \times 10^{-6} - 400 \times 10^{-6} \right) \\ & = \pm 5.5 \mu\text{V} \end{aligned}$$

The maximum error in the power indication is obtained from the maximum voltage error as follows:

Voltage uncertainty is 394.5 μV to 405.5 μV  
 In a 50 Ω system the equivalent power uncertainty,  
 calculated from V<sup>2</sup>/R, is 3112 pW to 3288 pW

$$= 3200 \text{ pW} \pm 88 \text{ pW}$$

The maximum power error is therefore ± 0.088 nW.



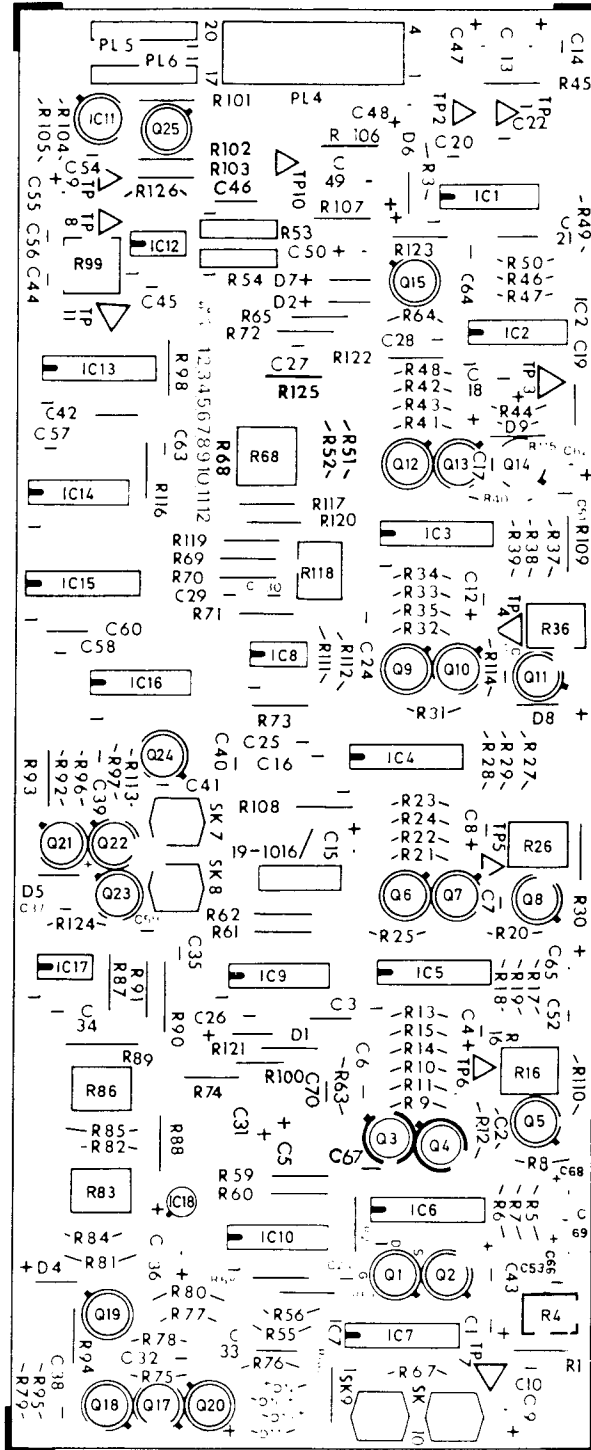

TABLE 1.1 (Continued)  
Technical Specification

ELECTRICAL CHARACTERISTICS (continued)	
Frequency Response:	For frequencies above 500 MHz a spot frequency correction factor, obtained from the frequency response curve on the measuring head, should be applied. This factor may be stored in the instrument to give automatic correction of the displayed measurement.
Insertion Loss:	A graph showing the variation of insertion loss with frequency is provided on the measuring head. The vertical scale of this graph is 0 to 3 dB in steps of 0.5 dB.
Crest Factor:	The range of crest factor of the measured waveform over which the specified accuracy will be maintained is shown in Fig. 1.1.

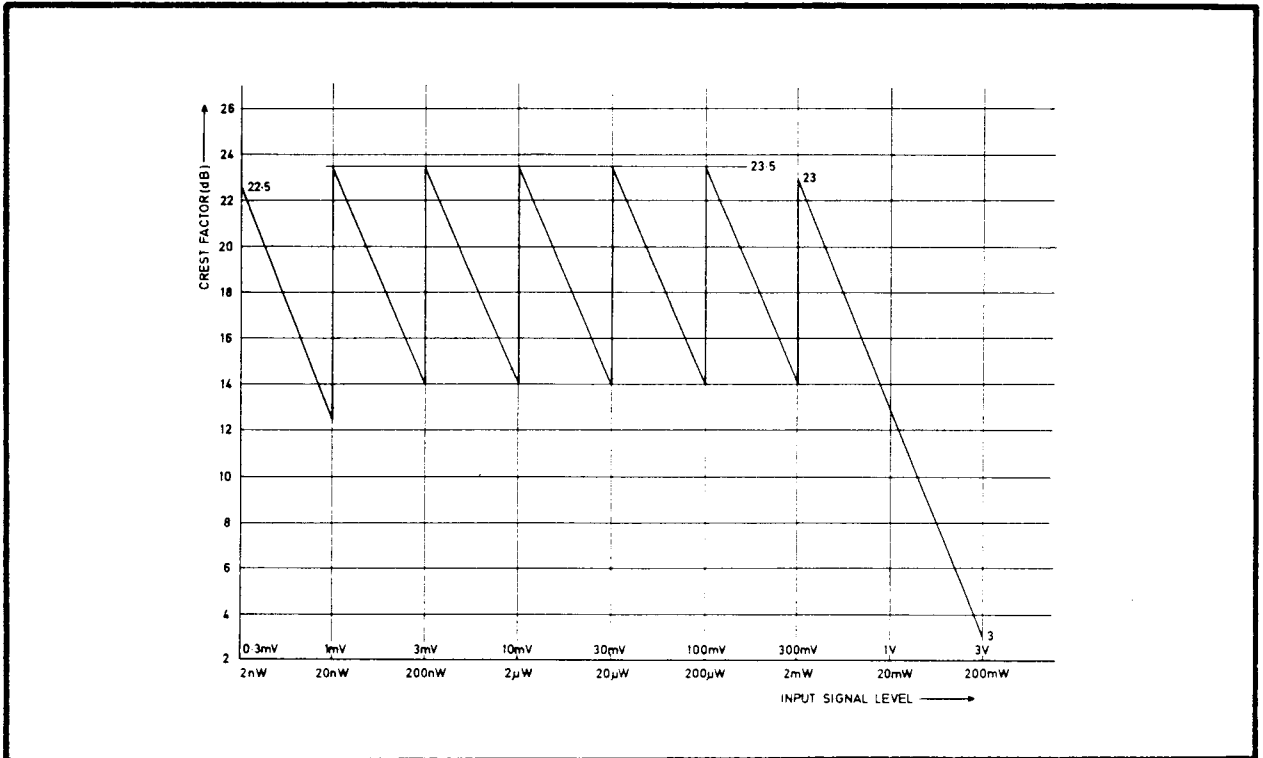

Fig. 1.1 Input Waveform Crest Factor Limits

TABLE 1.1 (continued)  
Technical Specification

ELECTRICAL CHARACTERISTICS (continued)	
Maximum Input Level:	<p>The maximum input signal levels which can be tolerated without damage to the measuring head are:</p> <p>For the measuring head alone (in line or unterminated) 20 V peak-to-peak <math>\pm</math>100 V DC.</p> <p>For the measuring head terminated with the matched 50 <math>\Omega</math> load, 7 V r.m.s. including any DC level present (1 W maximum).</p>
Averaging Time:	<p>The period between display updates, during which a number of measurements made are averaged, can be set in steps of 0.1 second between 0.1 second and 99.9 seconds (nominal). On switching on a value of 1 second is adopted automatically.</p>
Analogue Setting Time:	<p>A settling time of 3 seconds should be allowed after the application of the signal to be measured. This is independent of the averaging time in use.</p>
Input Connector:	<p>The measuring head is fitted with one male and one female Type N connector.</p>
MECHANICAL CHARACTERISTICS	
Instrument Dimensions:	<p>Height: 104 mm Width: 440 mm Depth: 403 mm</p>
Measuring Head Dimensions: (including connectors)	<p>Length: 125 mm Width: 45 mm Depth: 37 mm</p>
Instrument Weight:	<p>Approximately 6 kg.</p>

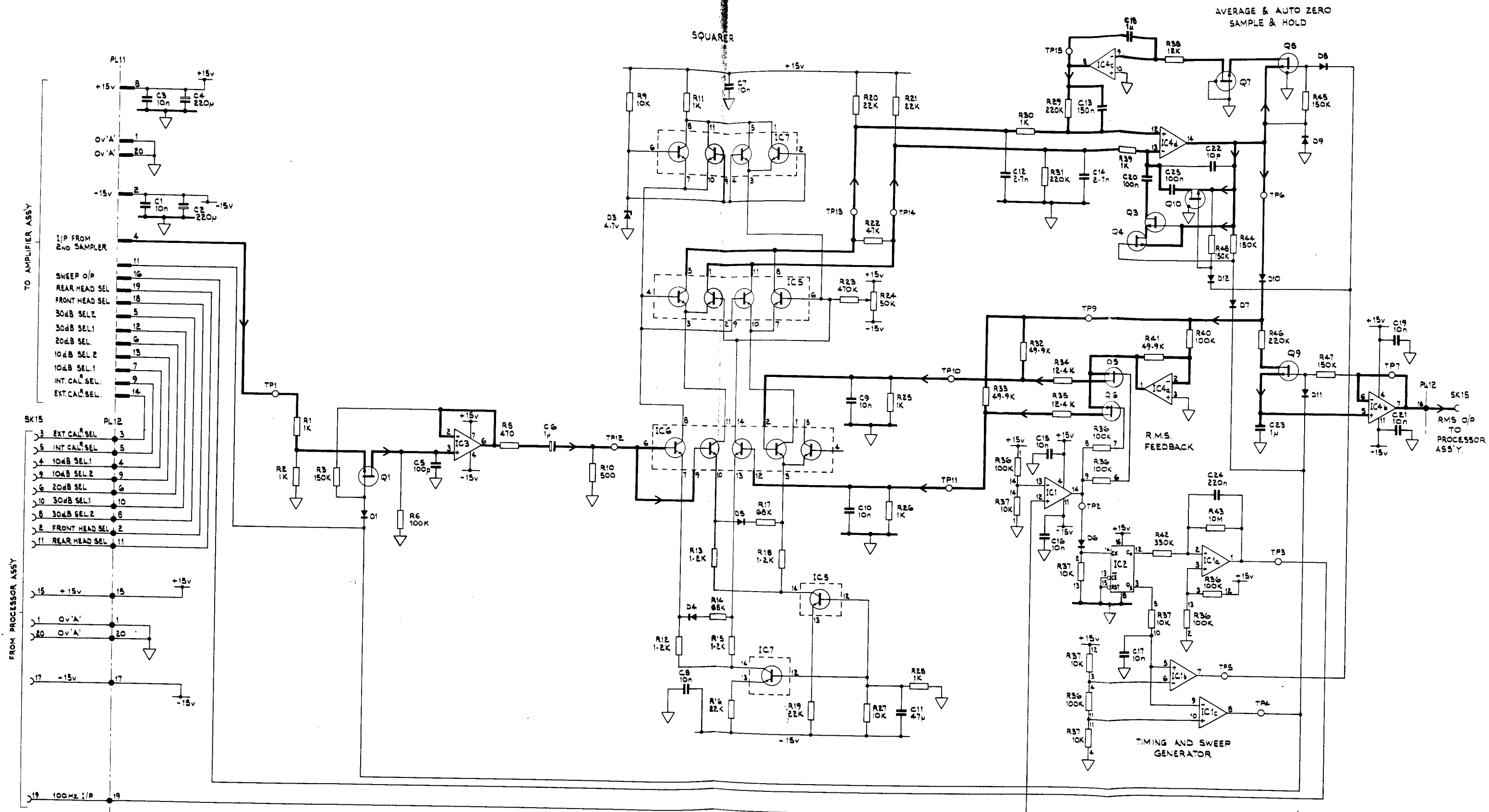

TABLE 1.1 (continued)

Technical Specification

POWER SUPPLIES	
Voltage:	A four range supply voltage selector is provided to accept 100 V, 115 V, 215 V or 230 V AC $\pm 10\%$ .
Frequency:	45 to 440 Hz.
Power Consumption:	Approximately 50 VA.
ENVIRONMENTAL SPECIFICATION	
Operating Temperature:	0°C to +55°C.
Storage Temperature:	-40°C to +70°C. Corruption of the non-volatile memory contents may occur at temperatures below -20°C.
Humidity:	95% RH at +40°C.
Electromagnetic Compatibility:	The instrument is designed to conform with TS 1400, Class A.
ACCESSORIES PROVIDED	
Power Lead:	Part number 23-3227
Fuse for 90/127 V Operation:	Part number 23-0052
Operator's Handbook:	

TABLE 1.1 (Continued)

Technical Specification

OPTIONAL ACCESSORIES	
High Impedance Probe:	X10, complete with Type N to BNC adaptor. Part number 11-1512.
Low Capacitance Probes:	20 dB, complete with Type N to BNC adaptor. Input impedance 500 $\Omega$ . Part number 11-1573. 40 dB, complete with Type N to BNC adaptor. Input impedance 5 k $\Omega$ . Part number 11-1574.
19-inch Rack Mounting Kit:	Part number 11-1496.
Additional Measuring Head:	Measuring head complete with matched 50 $\Omega$ load. With 1 metre cable, part number 11-1478 With 2 metre cable, part number 11-1540
GPIB INTERFACE	
Function Subsets:	The interface operates in accordance with the following IEEE/IEC defined subsets:  Source handshake SH1 Acceptor handshake AH1 Talker T5 Extended talker TE0 Listener L4 Extended listener LE0 Service request SR1 Remote local RL1 Parallel poll PPO Device clear DC1 Device trigger DT1 Controller CO
Interface type:	The interface uses open collector drivers, and is a type E1 interface as defined by IEEE standard 488.

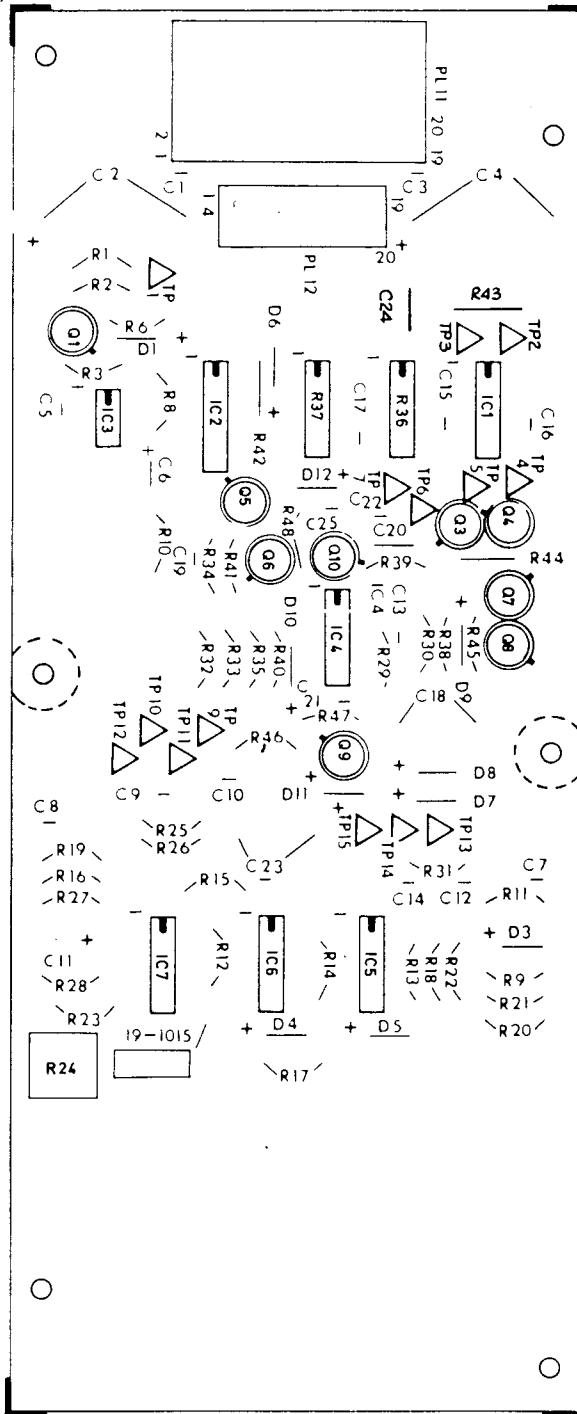

Component Layout:  
Signal Converter Assembly 19-1015

Fig.8

TABLE 1.1 (Continued)

Technical Specification

GPIB INTERFACE (continued)	
Address Setting:	<p>Five rear panel mounted switches allow the selection of any one of 31 pairs of addresses. Each pair consists of a talk and a listen address. The talk and listen addresses in a pair are distinguished by the logic levels on data lines DIO 6 and DIO 7. These logic levels are decoded by the 9303 when in the listen state, or set by the 9303 when in the talk state without operator action.</p> <p>A sixth switch enables the 9303 to be put to the talk only mode.</p>
Measurement Modes:	<p>When addressed via the GPIB two measurement modes are available:</p> <ol style="list-style-type: none"><li>(1) Continuous mode: The instrument performs continuous measurement cycles. The last measurement taken is put onto the bus when the instrument is put into the talk state.</li><li>(2) Single mode: The instrument performs a single measurement cycle in response to a trigger command (which may be addressed or the GET command). The measurement taken is put onto the bus when the instrument is put into the talk state. The instrument can be set to generate a service request (SRQ) when the measurement is complete.</li></ol> <p>When in the talk only mode the instrument performs continuous measurement cycles in accordance with the front panel control settings. The last measurement made is put onto the bus in response to a signal on the NRFD control line.</p>
Output Format:	<p>The output data word consists of a string of twelve ASCII characters.</p>
Optional Accessory:	<p>Adaptor to convert to IEC 625-1 GPIB. Racal-Dana part number 23-3254</p>



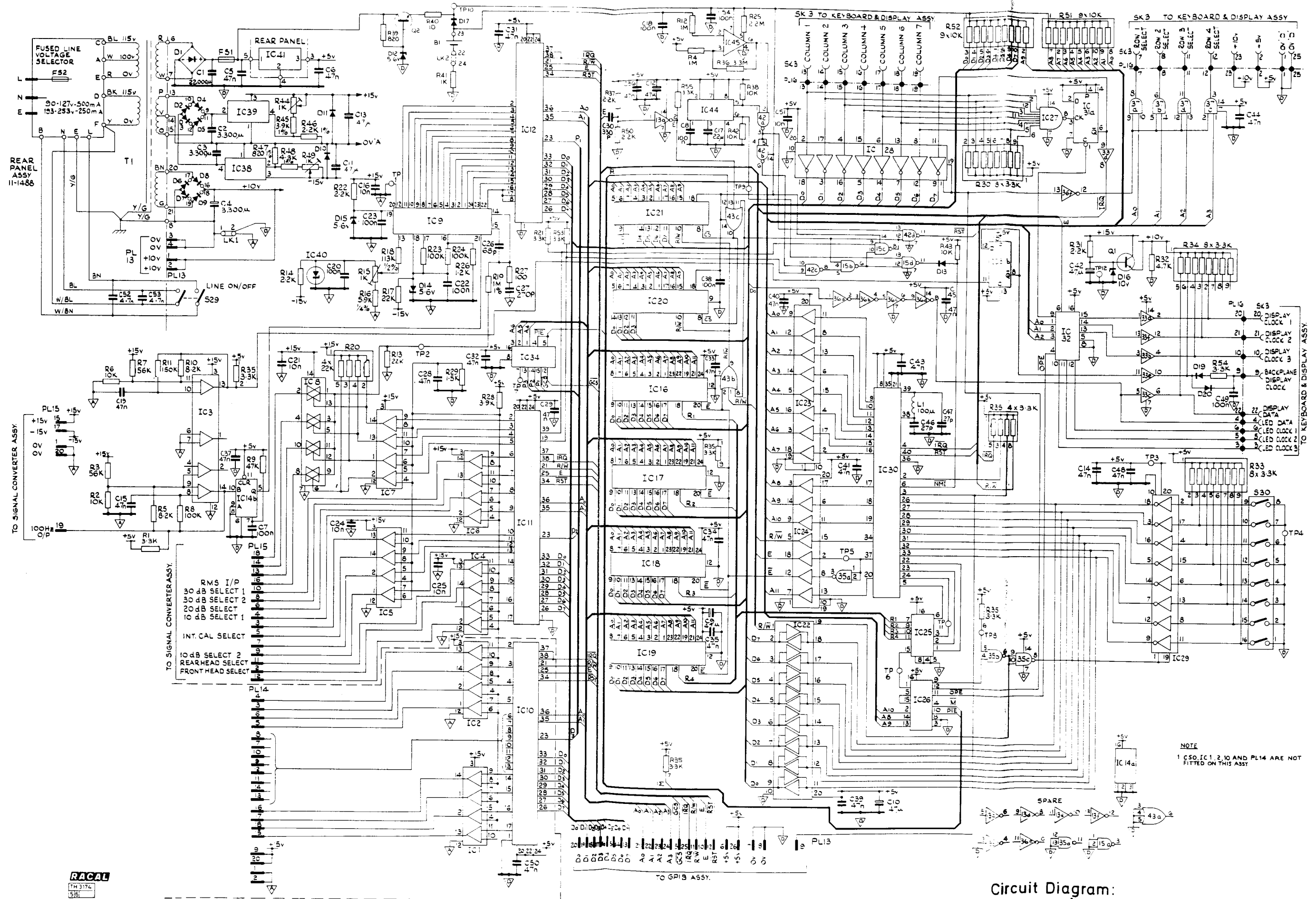

**RACAL**  
1H 3174  
516

Circuit Diagram:  
Processor Assembly 19-1014

## 2.1 INTRODUCTION

2.1.1 The Racal-Dana RF Level Meter Model 9303 is a versatile, microprocessor controlled instrument. It will make measurements on signals having crest factors up to 15 and r.m.s. voltage levels between 30  $\mu$ V and 3.162 V. The instrument has an auto ranging facility, but provision for manual setting of the range is provided.

2.1.2 The full quoted accuracy is obtained over a frequency range from 10 kHz to 2 GHz. The instrument features an auto calibration facility. The calibration factors relating to the measuring heads are stored during the calibration procedure, and are used to adjust the displayed measurement without further operator action. A calibration signal source is provided for use should re-calibration of the measuring heads become necessary.

2.1.3 The instrument measures the true r.m.s. voltage of the applied signal. This may be displayed in voltage units, or converted to:

- (a) Indication of power, computed as  $V^2/R$ , where R is a resistance value stored in the instrument.
- (b) Indication of power relative to a power level which has been stored in the instrument. This may be displayed as a numeric ratio or in dB.
- (c) Indication of the percentage difference between the measured voltage or the computed power and a voltage or power level which has been stored in the instrument.
- (d) Indication of the difference between the measured voltage or the computed power and a voltage or power level which has been stored in the instrument.
- (e) Indication of the ratio of the measured voltage to a voltage level which has been stored in the instrument. This may be displayed as a numeric ratio or in dB.

2.1.4 The instrument features a large, four digit, liquid crystal display (LCD). Coarse and fine light dot displays form part of the display, and provide a pseudo-analogue form of indication. Units annunciators, operation limit warning indicators and calibration factor indicators are also incorporated.

## 2.2 MEASURING HEAD

2.2.1 Measurements are made via a measuring head, connected to the instrument by a cable. Measuring heads with 1 metre and 2 metre cables are available. The head is provided with a matched 50  $\Omega$  load for use when the instrument is to act as the system termination, but may be used to make in-line measurements in an accurate 50  $\Omega$  system. The head may also be used with a 50  $\Omega$  attenuator, or in conjunction with passive probes. The measuring

head calibration procedure allows the measurement of a calibration factor for the head alone, and the measurement of an additional calibration factor relating to any measuring head attachments in use. The calibration factors are stored separately, and can be separately enabled and disabled.

2.2.2 The measuring head used determines the measurement frequency response. Each head is provided with its own response curve, a correction factor from which can be stored in the instrument to give automatic correction of the displayed measurement at the selected spot frequency. The entry of a spot frequency calibration factor acts in addition to the calibration factors stored during the measuring head calibration procedures.

2.2.3 Two measuring heads may be connected to the instrument, one at the front and one at the rear. Correction factors for both heads may be stored, the appropriate factor being selected as the measurement function is switched between the heads.

### 2.3 REDUCTION OF DISPLAY JITTER

2.3.1 The instrument has a variable averaging time, which may be set by the operator to ensure minimum jitter of the measurement indication when measurements are made on waveforms of high crest factor. The period over which measurements are averaged may be varied in steps of 0.1 second between 0.1 second and 99.9 seconds (nominal).

2.3.2 The display updating rate is set by the averaging time in use. To avoid the necessity for unacceptably low updating rates, continuous averaging of the measurements can be introduced by means of a special function. In this mode the display is updated every 0.1 second, the new displayed value being formed by adding N% of the current displayed value to (100-N%) of the new measurement. The effect of this is similar to filtering successive measurements in a single pole RC filter. The value of N is related to the time constant of the effective filter, which can be set by the operator.

### 2.4 NOISE CANCELLATION

2.4.1 As part of the measuring head calibration procedure the signal due to noise is measured and stored. This figure is subtracted from subsequent measurements to provide noise cancellation.

### 2.5 MEASUREMENT PRINCIPLES

2.5.1 Samples are taken of the voltage across the strip line conductor in the measurement head. The sampler output is passed through a variable gain amplifier, to provide different operating ranges. A second sampling system is used to convert the amplifier output to a low frequency signal having a true r.m.s. value proportional to that of the measured signal. A direct voltage proportional to the r.m.s. value of this signal is obtained, using a linearised transconductance multiplier in a feedback loop.



2.5.2 To ensure that errors do not arise due to the first sampling frequency being a sub-harmonic of the measured signal frequency, a pseudo-random sampling waveform is generated from the output of a swept frequency oscillator.

2.5.3 The multiplier loop output is converted to digital form for processing by the microprocessor. The signal may be converted directly to a display segment drive signal, giving a display in voltage units, or processed, together with the contents of various internal stores, to provide power, percentage difference or difference displays.

## 2.6 STORAGE OF FRONT PANEL SETTINGS

2.6.1 Provision is made for the storage of up to 12 complete sets of front panel control settings, including the relevant calibration factors and computed function stores contents, in a non-volatile memory. Each setting is allocated a number, and can be retrieved by recalling that number.

## 2.7 GPIB INTERFACE

2.7.1 An internally mounted interface board permits the instrument to be controlled from and communicate with the IEEE 488 GPIB. The instrument may be used in the addressed mode or in the talk only mode. An adaptor to permit use with the IEC 625-1 GPIB is also available.

## 2.8 MAINTENANCE

2.8.1 It is recommended that customers should take advantage of the servicing and calibration service offered by Racal-Dana Instruments Ltd., and their agents.

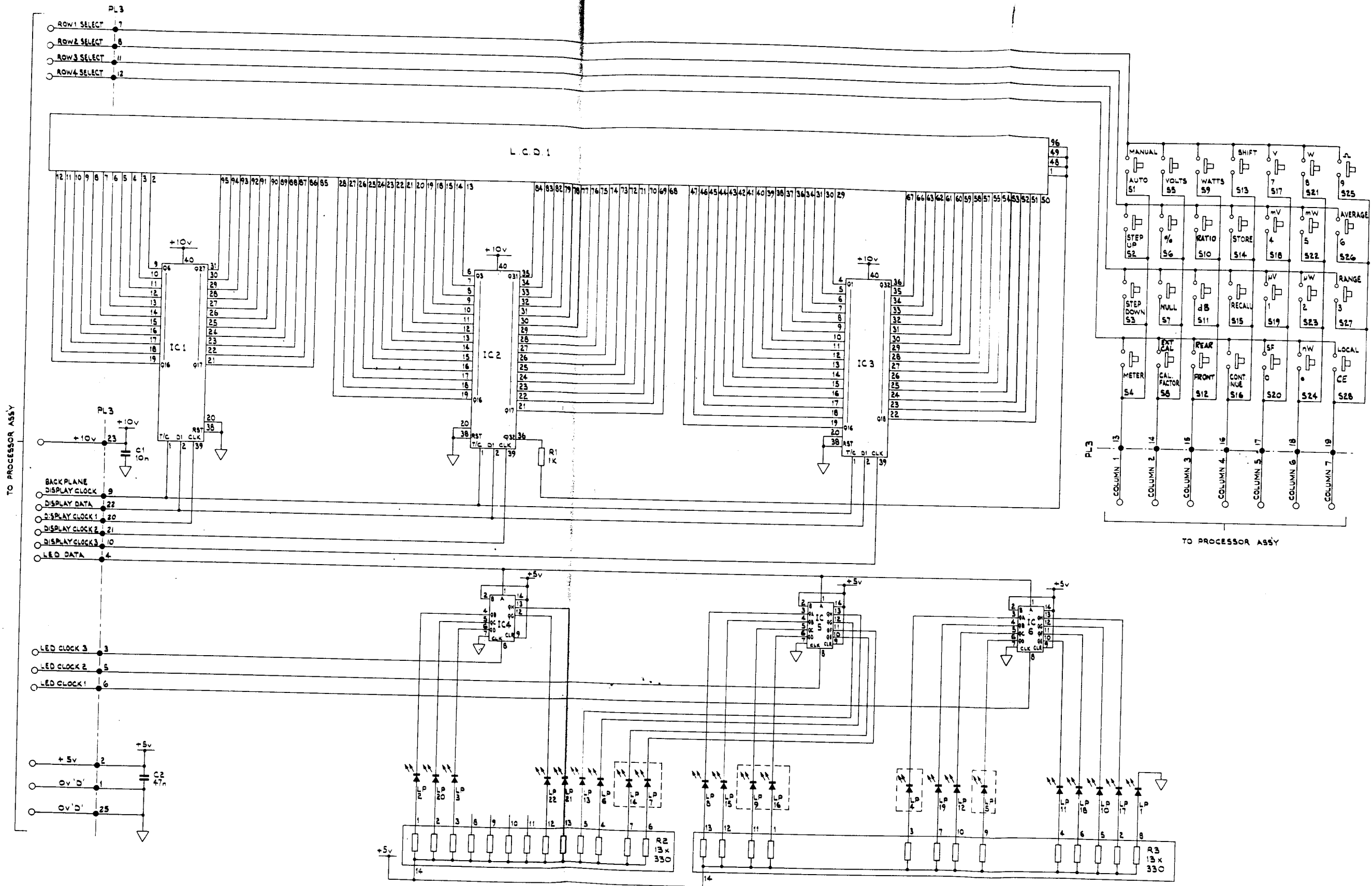

RACAL  
TH3174

Circuit Diagram: Keyboard and Display Assembly 19-1013

## 3.1 INTRODUCTION

3.1.1 This section contains instructions concerning all tasks which must be performed before taking the 9303 into use for the first time, or when the instrument is used at a new location. It includes instructions for mounting the equipment in an equipment rack, if this is required, and for preparing the instrument for connection to a GPIB controlled system.

## 3.2 POWER SUPPLY

### 3.2.1 AC VOLTAGE RANGE SETTING

3.2.1.1 The supply voltage setting is varied by changing the position of a small printed circuit board, located under the fuse on the rear panel. The setting in use can be seen through the clear plastic fuse cover.

3.2.1.2 If it is necessary to change the voltage range proceed as follows:

- (a) Switch the instrument off, and remove the line power socket.
- (b) Slide the clear plastic fuse cover to the left, to expose the fuse.
- (c) Pull the lug marked FUSE PULL out and to the left. This will remove one end of the fuse from its holder. Remove the fuse.
- (d) Using a pair of snipe nosed pliers, pull out the voltage setting board from beneath the fuse holder.
- (e) Reinsert the board so that the required voltage range can be read the correct way up, when viewed from above, looking at the rear of the instrument.
- (f) Push the lug marked FUSE PULL back into position.
- (g) Insert the correct fuse for the range selected into the fuse holder.
- (h) Slide the clear plastic cover to the right until it is clear of the line power plug. Insert the line power socket.

### 3.2.2 LINE FUSE

3.2.2.1 Check that the line fuse rating is correct for the local AC supply voltage. The fuse is a  $\frac{1}{4}$  in x  $1\frac{1}{4}$  in glass cartridge, surge resisting type. The Racal-Dana part numbers for replacement fuses are:-

90 V to 127 V supply	500 mAT	23-0052
193 V to 253 V supply	250 mAT	23-0056

### 3.2.3 DC FUSE

3.2.3.1 Check that the DC fuse fitted to printed circuit board 19-1014 is serviceable, and of the correct rating. The fuse should be a 1.6 AT, surge resisting,  $\frac{1}{4}$  in x  $1\frac{1}{4}$  in glass cartridge type, Racal-Dana part number 23-0055. Instructions for the removal and replacement of the covers are given in paragraph 3.5.

### 3.2.4 POWER LEAD

3.2.4.1 The power lead must be fitted with a suitable connector in accordance with the standard colour code.

	<u>European</u>	<u>American</u>
Live	Brown	Black
Neutral	Blue	White
Earth(Ground)	Green/Yellow	Green

### 3.3 CONNECTION OF MEASURING HEADS

3.3.1 Connect the measuring head(s) to the appropriate INPUT socket(s). The instrument is supplied with a single measuring head, which bears the same serial number as the instrument, and is calibrated to permit this head to be used in either INPUT socket. If an additional measuring head is obtained, a FACTORY ECAL for this head must be performed in one INPUT socket in accordance with the instructions given in Section 4. This will destroy the calibration factor for that socket relating to the original head. The heads must then only be connected to the sockets calibrated for their use.

3.3.2 If the measuring head is connected to make through-line measurements, measurement accuracy may be adversely affected by the system VSWR.

3.3.3 If the measuring head is required to form a  $50 \Omega$  termination to a signal circuit it should be terminated with the matched  $50 \Omega$  load provided. If the signal is to be connected to the measuring head via a  $50 \Omega$  attenuator a USER ECAL factor for the measuring head and attenuator can be measured and stored. The procedure for this is given in Section 4. When enabled, this factor will compensate for the attenuator value.

3.3.4 The input impedance of the unterminated measuring head at low frequencies is approximately  $100 \text{ k}\Omega$  in parallel with  $20 \text{ pF}$ , but the head may be used with passive probes to achieve other input impedances. If this is done a USER ECAL factor should be measured and stored and a calibration factor should be calculated and stored for use with the combination, as instructed in Section 4.

3.3.5 Customers requiring advice on the use of the 9303 in special systems should provide full details of the proposed application to Racal-Dana Instruments at the address given on the title page of this manual.



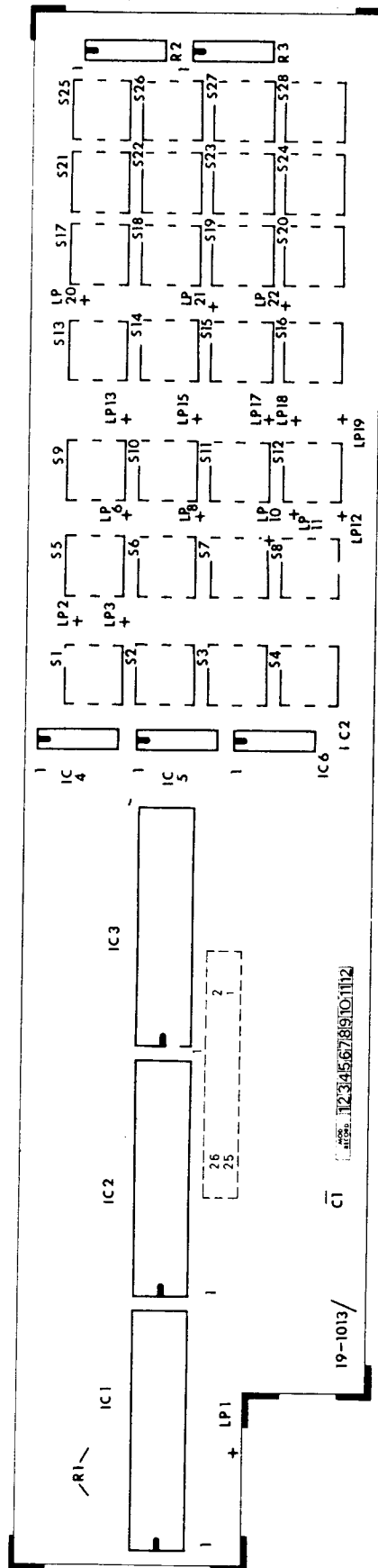

Component Layout:  
Keyboard and Display Assembly 19-1013

Fig. 4

### 3.4 FITTING THE FIXED RACK MOUNTING KIT 11-1496

3.4.1 The kit contains a pair of mounting brackets and four screws. The method of fitting the kit is shown in Fig. 3.1. The fitting procedure is as follows:

- (a) Switch off the instrument and the AC supply. Remove the line power socket.
- (b) Stand the instrument upside down on a bench, and remove the two screws from each of the plastic mouldings at the rear corners of the instrument. Remove the mouldings.
- (c) Slide the bottom cover towards the rear of the instrument by about 1 inch, and lift the cover off.
- (d) Remove the bench feet from the bottom cover by removing the retaining screw from each foot. Replace the bottom cover.
- (e) Remove the side trim panels by sliding them to the rear of the instrument. Replace and secure the plastic mouldings removed in (b).
- (f) Remove the two screws securing the handle at one side of the instrument. Do not remove the handle.
- (g) Position a bracket from the kit at the side of the instrument, so that the two holes in a flange are positioned over the holes for the handle securing screws.
- (h) Secure the handle and bracket, using two of the countersunk headed screws from the kit.
- (j) Repeat (f) to (h) at the other side of the instrument.

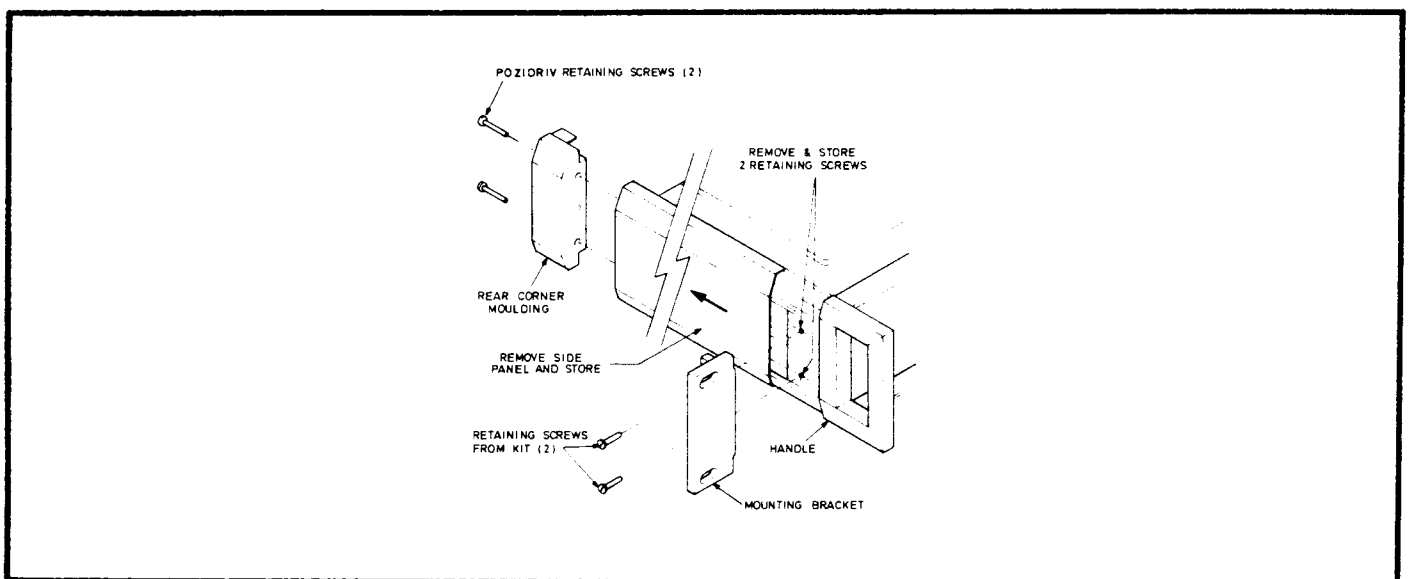

Fig. 3.1 Fitting the Fixed Rack Mounting Kit

### 3.5 REMOVAL AND REPLACEMENT OF THE COVERS

WARNING: DANGEROUS AC VOLTAGE LEVELS ARE EXPOSED WHEN THE COVERS ARE REMOVED WITH THE AC SUPPLY CONNECTED.

- 3.5.1 (a) Switch off the instrument and the AC supply. Remove the line power socket.
- (b) Stand the instrument on its front handles, and remove the two screws from each of the plastic mouldings at the rear corners of the instrument. Remove the mouldings.
- (c) The covers can now be removed by sliding them towards the rear of the instrument. Note that the removal of the plastic mouldings also releases the side trim panels, which should either be removed or secured by replacement of the mouldings.
- (d) The covers are replaced in the reverse manner. Note that the straight, unfolded edge of the cover fits to the front of the instrument, and locates in a groove in the rear face of the front panel. The rear edge of the cover is folded under, and locates in a groove in the rear panel.

### 3.6 PREPARATION FOR USE WITH THE GPIB

#### 3.6.1 INTERFACE CONNECTOR

- 3.6.1.1 Connection to the GPIB is made via an IEEE 488 standard connector. The pin assignment is given in Table 3.1. An adaptor, Racal-Dana part number 23-3254, to convert the connector to the IEC 625-1 standard is available as an optional accessory.

TABLE 3.1

GPIB Connector Pin Assignment

Pin	Signal Line	Pin	Signal Line
1	DIO 1	13	DIO 5
2	DIO 2	14	DIO 6
3	DIO 3	15	DIO 7
4	DIO 4	16	DIO 8
5	EOI	17	REN
6	DAV	18	Gnd.(6)
7	NRFD	19	Gnd.(7)
8	NDAC	20	Gnd.(8)
9	IFC	21	Gnd.(9)
10	SRQ	22	Gnd.(10)
11	ATN	23	Gnd.(11)
12	SHIELD	24	Gnd.(5 and 17)

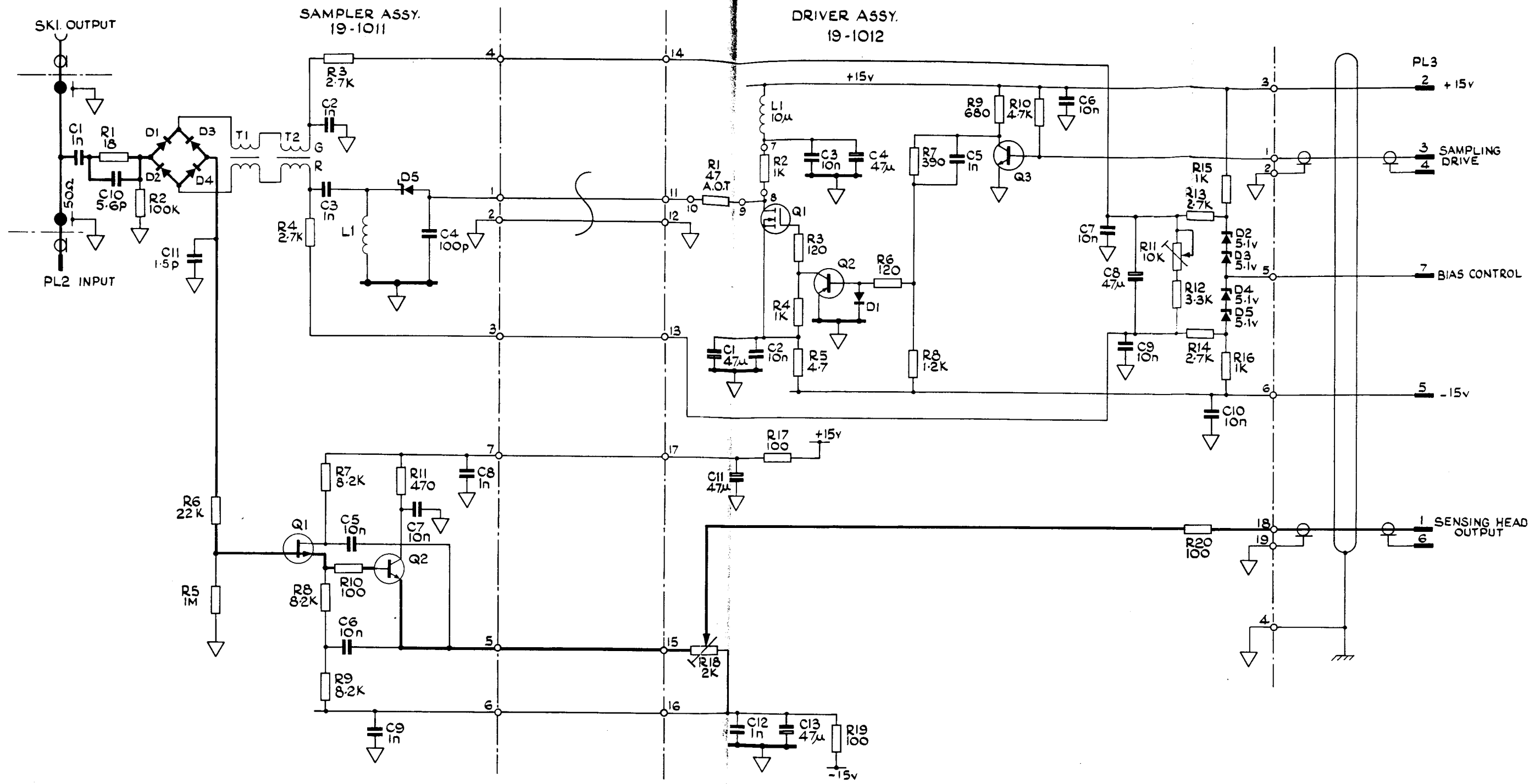

**RACAL**  
 TH3174  
 2/3

Circuit Diagram: Measuring Head 11-1478 or 11-1540

Fig.3

## 3.6.2 ADDRESS SETTING

3.6.2.1 The interface address is set on five rear panel mounted switches. The right hand switch, as viewed from the rear of the instrument, is for bit 1, the least significant address bit. The permitted address settings, in decimal and ASCII character form, are given in Table 3.2. The instrument is despatched with the address switches set to ASCII , (listen) and ASCII L (talk). The address set, in decimal format, can be displayed by pressing

/RECALL//SHIFT//LOCAL/.

3.6.2.2 The sixth switch, when put to the logic '1' position, puts the interface into the talk only mode. With the switch in this position the settings of the first five switches are irrelevant.

TABLE 3.2

Address Switch Settings

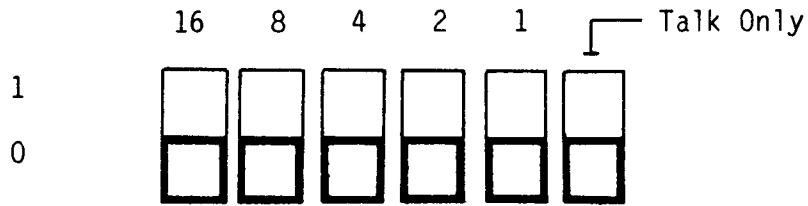

SWITCH SETTINGS					ADDRESS CODES		
					DECIMAL	ASCII LISTEN ADDRESS	ASCII TALK ADDRESS
16	8	4	2	1			
0	0	0	0	0	0	SP	@
0	0	0	0	1	1	!	A
0	0	0	1	0	2	"	B
0	0	0	1	1	3	#	C
0	0	1	0	0	4	\$	D
0	0	1	0	1	5	%	E
0	0	1	1	0	6	&	F
0	0	1	1	1	7	'	G
0	1	0	0	0	8	(	H
0	1	0	0	1	9	)	I
0	1	0	1	0	10	*	J
0	1	0	1	1	11	+	K
0	1	1	0	0	12	,	L
0	1	1	0	1	13	-	M
0	1	1	1	0	14	.	N
0	1	1	1	1	15	/	O
1	0	0	0	0	16	0	P
1	0	0	0	1	17	1	Q
1	0	0	1	0	18	2	R
1	0	0	1	1	19	3	S
1	0	1	0	0	20	4	T
1	0	1	0	1	21	5	U
1	0	1	1	0	22	6	V
1	0	1	1	1	23	7	W
1	1	0	0	0	24	8	X
1	1	0	0	1	25	9	Y
1	1	0	1	0	26	:	Z
1	1	0	1	1	27	::	[
1	1	1	0	0	28	<	\
1	1	1	0	1	29	=	]
1	1	1	1	0	30	>	^

Instrument despatched with this setting

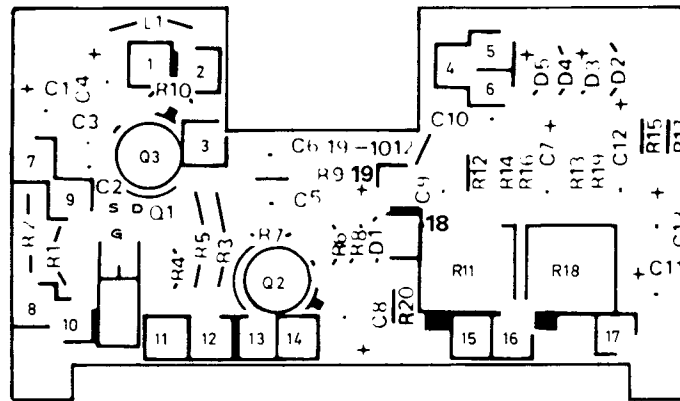

ASSEMBLY 19-1012

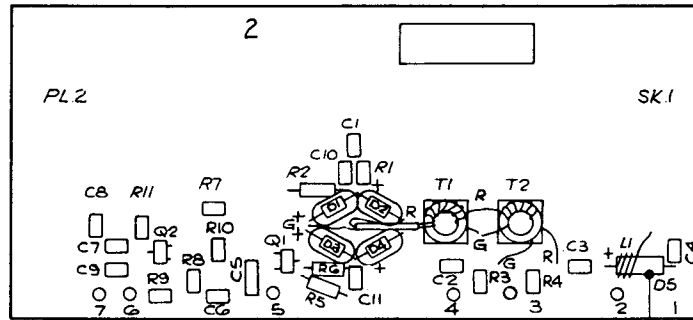

TRACKSIDE VIEW

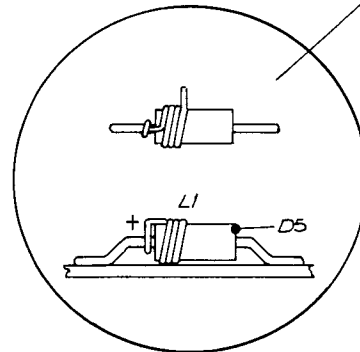

DETAIL OF D5/L1

ASSEMBLY 19-1011

## 4.1 INTRODUCTION

4.1.1 The first part of this section contains instructions for operating the 9303 using the front panel controls. This information is given in two forms. The purpose of each control is given in paragraph 4.2. This is followed by specific instructions on how to calibrate the instrument for use with different measuring head attachments, and how to set the instrument to make particular types of measurement.

4.1.2 Information regarding the control of the instrument using the GPIB is given, commencing at paragraph 4.21. It is essential that the operation of the instrument using the front panel controls is understood before operation using the GPIB is attempted.

## 4.2 DESCRIPTION OF CONTROLS, INDICATORS AND CONNECTORS

4.2.1 Each group of controls or connectors described is numbered to correspond with the indicators on Fig. 4.1 (front panel) or Fig. 4.2 (rear panel).

### 4.2.2 FRONT PANEL ITEMS

- ① Display: A custom-built, liquid crystal display is used. It incorporates the following indicators:
- (a) Four digit alpha-numeric display.  
This display, with decimal point and sign indicator, is used primarily to indicate the value of the measured quantity. It may also be used to display the values held in the instrument's internal stores, or to indicate certain types of error.
  - (b) Units annunciators.  
These indicate the units of the measurement being displayed.
  - (c) Compute function indicators.  
These indicate when the measurement functions requiring computation by the microprocessor (ratio, % difference, difference (null) or relative power (dB)) are in use.
  - (d) CF indicator.  
This provides warning that the calibration of the instrument has been changed by the introduction of operator set calibration factors.



- (e) GPIB indicators  
These indicate whether the instrument is under remote or local control, whether it is talking or listening and whether it is generating a service request.
- (f) Analogue display  
This is a two part, coarse and fine light dot display. The upper, coarse, section has ten dots, and indicates the measured value to within -0%, +10% of full scale. The lower, fine, section also has ten dots, representing sub divisions of the coarse section. The overall indication is therefore within -0% and +1% of full scale.  
The coarse section of the display is enabled automatically when manual range selection is in use. The complete display may be enabled by pressing  
/METER//METER/

② Range Control Keys: /MANUAL/  
This key selects the auto-ranging and manual ranging modes on alternate operations. The appropriate indicator will light to show the mode in use. On switching from auto to manual no change of range will take place.

/STEP UP/ and /STEP DOWN/  
These keys permit the next range above or below the one in use to be selected when in the manual ranging mode. If these keys are operated when the instrument is in the auto-ranging mode, the manual ranging mode will be selected and the appropriate change of range will occur.

③ METER Key:  
This switches the analogue display on and off on successive operations.  
The coarse part of the analogue display is switched on automatically when the manual ranging mode is selected. It will be switched off by the first operation of the METER key, subsequent operations of the key controlling the complete analogue display.

④ Primary Measuring Function Keys:  
These keys allow the measured value to be displayed in voltage or power units. The appropriate indicator will light to show which function is in use.  
The instrument measures true r.m.s. volts. When display in power units is demanded, the measured voltage is converted using the resistance value stored in the  $\Omega$  store.

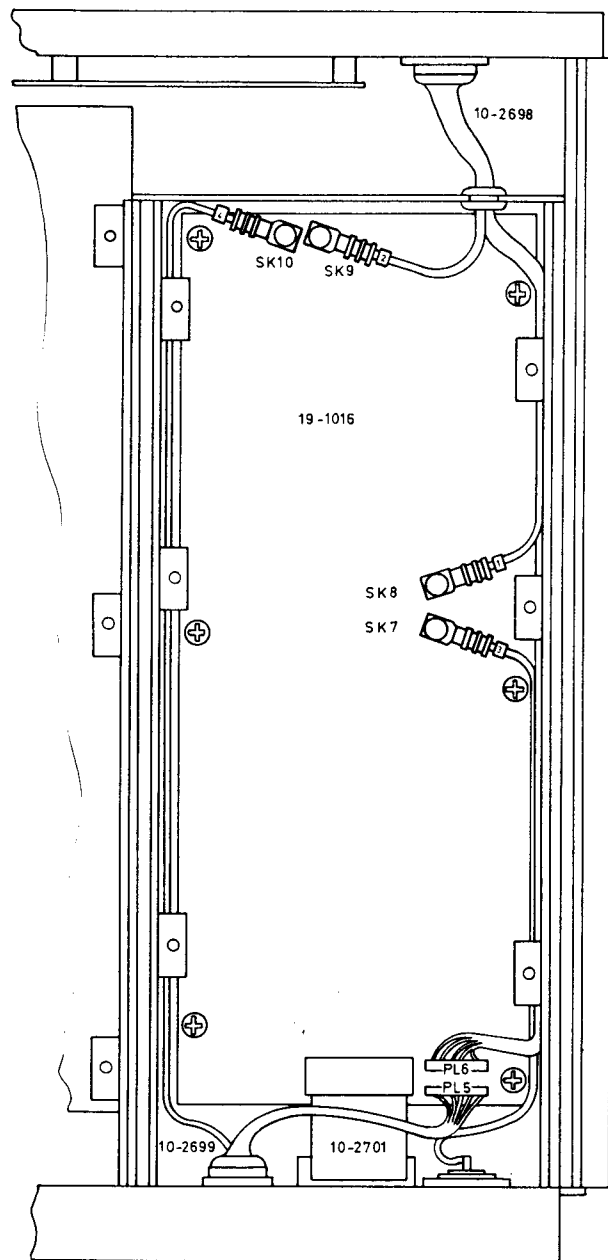

VIEW OF UNDERSIDE OF MODULE ASSEMBLY

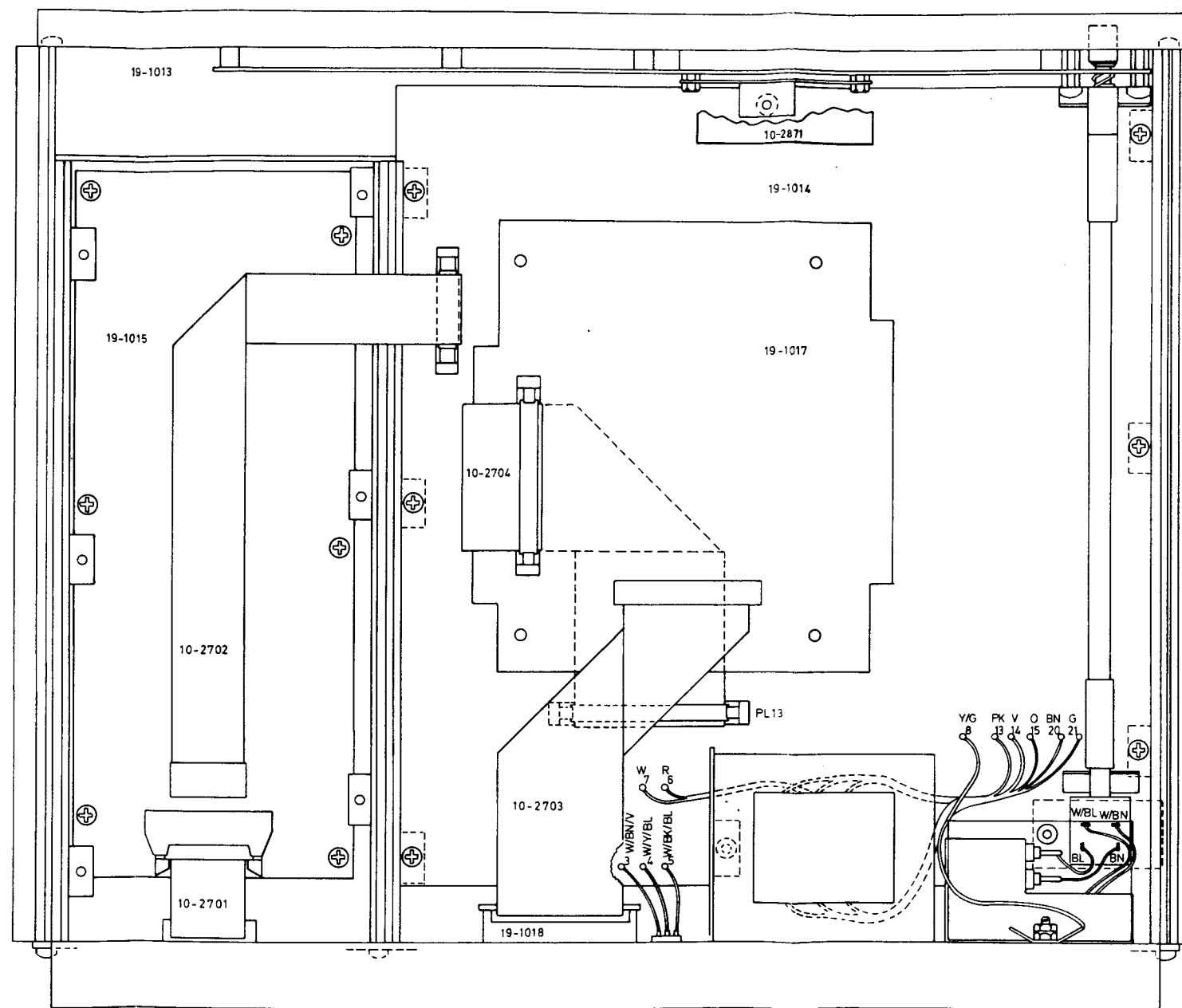

Internal Layout

⑤ Computed Measuring  
Function Keys:

These keys allow one of the four computed measuring functions to be selected. The appropriate indicator will light to show the function selected.

If the Voltage primary measuring function is in use the computations for all four functions will be performed in voltage units. If the Watts primary measuring function is in use the computations for the ratio, % difference and difference (null) functions will be performed in power units. The resistance value stored in the  $\Omega$  store is used in the conversion from voltage to power units. The computation for the relative power (dB) function is always performed in voltage units.

The keys also act as the address keys for the computed function stores. The LED adjacent to the appropriate key will light when a stored value is recalled.

⑥ Calibration Key:

The key is used without /SHIFT/ for the following purposes:

- (a) Successive operations of the key will enable and disable the calibration factor for the measuring head in use. The indicator will light when the calibration factor is enabled.
- (b) The sequence/RECALL//CAL FACTOR/ will result in the display showing the current value held in the calibration factor store.
- (c) The sequence/STORE//CAL FACTOR/ will store the number shown on the display in the calibration factor store. (The number displayed will have been set by means of the numeric keys).

The key is used with /STORE//SHIFT/ to measure and store a USER ECAL factor relating to any measuring head attachments which are used. This calibration factor is enabled, and disabled by successive operations of /SHIFT//EXT CAL/. The indicator will light when the USER ECAL factor is enabled. The indicator will flash, following switching on of the instrument, if the measuring head ECAL factor, stored in the non-volatile memory, is corrupted.

- ⑦ Front/Rear Selector Key: This selects the front or rear measuring head on successive operations. The appropriate indicator will light to show the head in use. Selection of the measuring head also selects, but does not necessarily enable, the appropriate head USER ECAL factor or any frequency calibration factor stored.
- ⑧ SHIFT Key: Pressing this key results in the next key pressed performing its shifted function. The shift operation affects the next key operation only, and cannot be continuously set.
- ⑨ STORE Key: This key is used, in conjunction with a store address key, to enter values in the instrument's internal stores. The instrument returns to the measurement mode when storage is completed. The indicator lights when the key is pressed, and is extinguished when storage is completed.
- ⑩ RECALL Key: This key is used, in conjunction with a store address key, to recall values from the instrument's internal stores. The use of the key stops the instrument measuring, so that the recalled information can be shown on the display, except in the case of recall of complete front panel settings. In this case the instrument returns to the measurement mode, with the recalled values set, as soon as the recall action is completed. The indicator lights when the key is pressed, and is extinguished when the instrument returns to the measurement mode, or when a new value is entered into store.
- ⑪ CONTINUE Key: Operation of this key returns the instrument to the measurement mode following the display of the contents of the instrument's internal stores.
- ⑫ Numeric Keypad: These keys, used without /SHIFT/, provide the means of setting, on the display, values to be entered in the instrument's internal stores. A CE key is included to allow clearance of entries containing errors.

PARTS LIST

GPIB CONNECTOR ASSEMBLY 19-1018

Fig. 15

<u>Cct. Ref.</u>	<u>Value</u>	<u>Description</u>	<u>Rat</u>	<u>Tol %</u>	<u>Racal Dana Part Number</u>
		Cableform Assembly			10-2703
		Socket, DIL, 16-way			23-3140
SK19		Receptacle, IEEE-488			23-3314
S30		Switch, DIL			23-4102

The keys are used, with /SHIFT/, to add units annunciators to values to be stored, to address the  $\Omega$  and response time (average) stores, to display the full scale deflection value of the measurement range in use and to select the special functions (SF). Pressing /SHIFT//LOCAL/ will return the instrument to local control from remote control via the GPIB except when the instrument is operating in the remote control with local lockout mode (RWLS).

⑬ CALIBRATOR Socket:

This socket provides a 0dBm in 50  $\Omega$  calibration signal for use when carrying out the measuring head calibration procedure. The output has a 500 kHz pulse waveform of approximately unity mark/space ratio. The output is normally disabled but may be enabled by means of special function commands entered via the front panel controls.

The rear panel CAL OUTPUT socket is wired in parallel with the CALIBRATOR socket. The correct output level is given when one socket only is loaded with 50  $\Omega$ .

⑭ INPUT Socket:

This socket accepts the front measuring head cable. The socket is connected to the measuring circuit when the FRONT indicator is lit.

⑮ LINE Switch and Indicator:

This switch controls the AC supply to the instrument power supply circuit. The indicator lights when the instrument is switched on.

4.2.3 REAR PANEL ITEMS

⑯ CAL OUTPUT Socket:

This socket provides a 0dBm in 50  $\Omega$  calibration signal for use when carrying out the measuring head calibration procedure. The output has a 500 kHz pulse waveform of approximately unity mark/space ratio. The output is normally disabled, but may be enabled by means of special function commands entered via the front panel controls.

The front panel CALIBRATOR socket is wired in parallel with the CAL OUTPUT socket. The correct output level is given when one socket only is loaded with 50  $\Omega$ .

Cct. Ref.	Value	Description	Rat	Tol %	Racal Dana Part Number
IC6		4066			22-4761
IC7		74LS74			22-4534
IC8		74LS02			22-4532
IC9		74LS125			22-4657
IC10		74LS74			22-4534
IC11		74LS10			22-4557
IC12		74LS240			22-4588
IC13		3447			22-8304
IC14		74LS04			22-4533
IC15		74LS138			22-4587
IC16		Not Used			
IC17		7805			22-4222
IC18		74LS10			22-4557
IC19		74LS245			22-4584
 <u>Connectors</u>					
PL21		PCB header, 34-way			23-3325
PL22		PCB header, 34-way			23-3325

- ①⑦ INPUT Socket: This socket accepts the rear measuring head cable. The socket is connected to the measuring circuit when the REAR indicator is lit.
- ①⑧ GPIB Socket: This socket is wired for direct connection to the IEEE 488 bus. An adaptor to permit the instrument to be used with the IEC 625-1 bus is available as an optional accessory.
- ①⑨ Address Switches: The five left hand switches allow one of 31 Listen/Talk address pairs to be selected. Putting a switch to the up position represents a logic '1'. The right hand switch represents the least significant bit (bit 1, on DIO 1).
- The sixth switch, when put to the up position, selects the talk only mode. The setting of the remaining address switches is then irrelevant.
- ②⑦ Supply Voltage Range Selector: This allows the selection of one of four line voltage ranges. The range selected can be read on the selecting plate through the clear plastic cover.
- ②① Line Fuse: The fuse is a  $\frac{1}{4}$  in x  $1\frac{1}{4}$  in glass cartridge pattern, and should be of the anti-surge type.
- ②② Line Power Plug: The power input plug incorporates a filter, and external supply filtering should be unnecessary.



PARTS LIST  
GPIB ASSEMBLY 19-1017

Fig. 13

Cct. Ref.	Value	Description	Rat	Tol %	Racal Dana Part Number
--------------	-------	-------------	-----	----------	---------------------------

Resistors

	$\Omega$		$W$		
R1	3.3 k	Carbon Film	$\frac{1}{4}$	5	20-2332
R2	3.3 k	Carbon Film	$\frac{1}{4}$	5	20-2332
R3	3.3 k	Carbon Film	$\frac{1}{4}$	5	20-2332
R4	3.3 k	Carbon Film	$\frac{1}{4}$	5	20-2332
R5	3.3 k	Carbon Film	$\frac{1}{4}$	5	20-2332
R6	3.3 k	Carbon Film	$\frac{1}{4}$	5	20-2332
R7	3.3 k	Carbon Film	$\frac{1}{4}$	5	20-2332
R8	3.3 k	Carbon Film	$\frac{1}{4}$	5	20-2332
R9	3.3 k	Carbon Film	$\frac{1}{4}$	5	20-2332
R10	8x3.3 k	DIL Array			20-5525
R11	56	Carbon Film	$\frac{1}{4}$	5	20-2560

Capacitors

	$F$		$V$		
C1	10 n	Ceramic	25	-20+80	21-1545
C2	47 $\mu$	Electrolytic	25	20	21-0789
C3	47 $\mu$	Electrolytic	25	20	21-0789
C4	100 n	Ceramic	12	-20+80	21-1616
C5	100 n	Ceramic	12	-20+80	21-1616
C6	100 n	Ceramic	12	-20+80	21-1616
C7	100 n	Ceramic	12	-20+80	21-1616
C8	100 n	Ceramic	12	-20+80	21-1616
C9	100 n	Ceramic	12	-20+80	21-1616
C10	10 n	Ceramic	25	-20+80	21-1545

Integrated Circuits

IC1	74LS30				22-4597
IC2	68488				22-8305
IC3	3447				22-8304
IC4	74LS86				22-4566
IC5	74LS30				22-4597

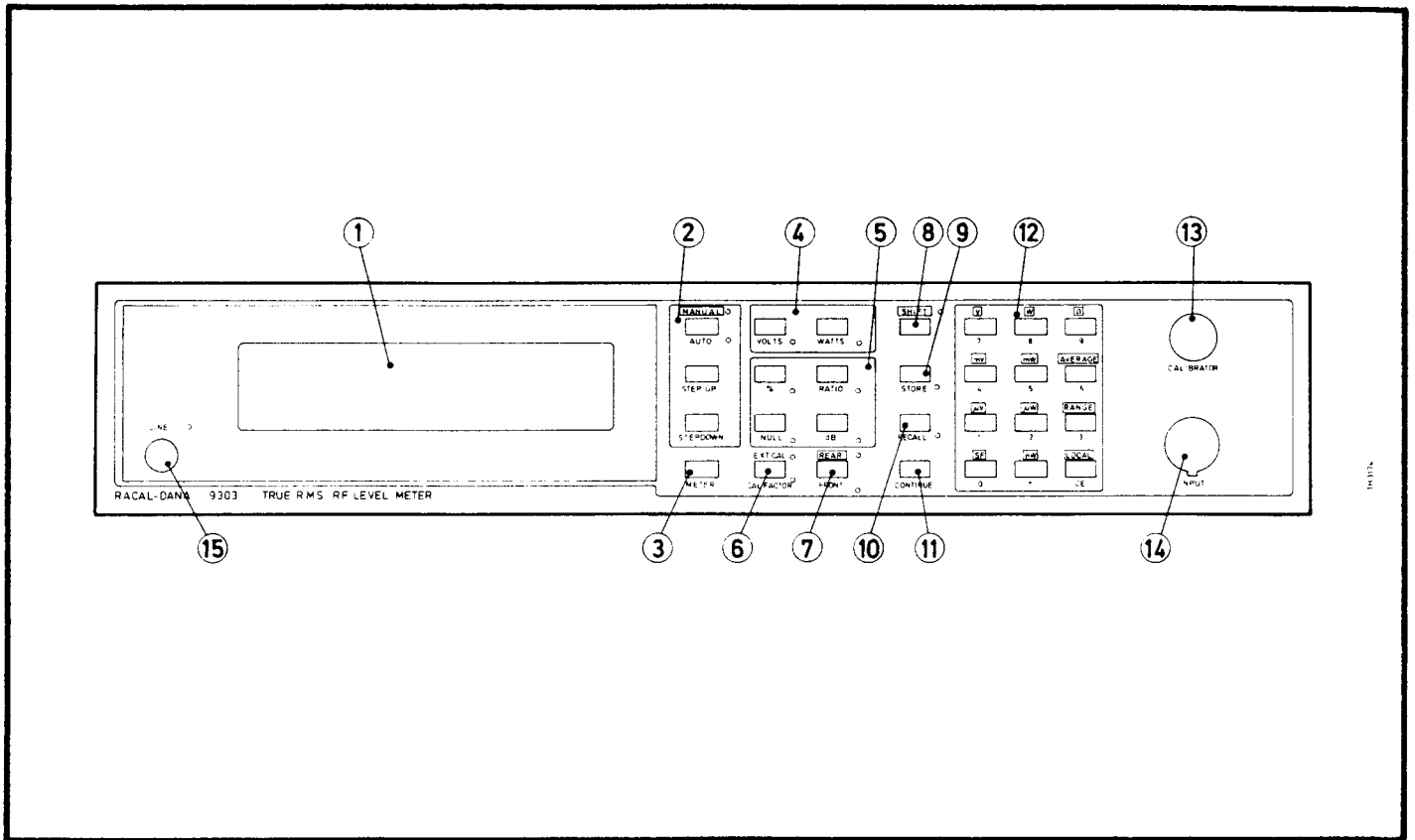

Fig. 4.1 Front Panel Layout

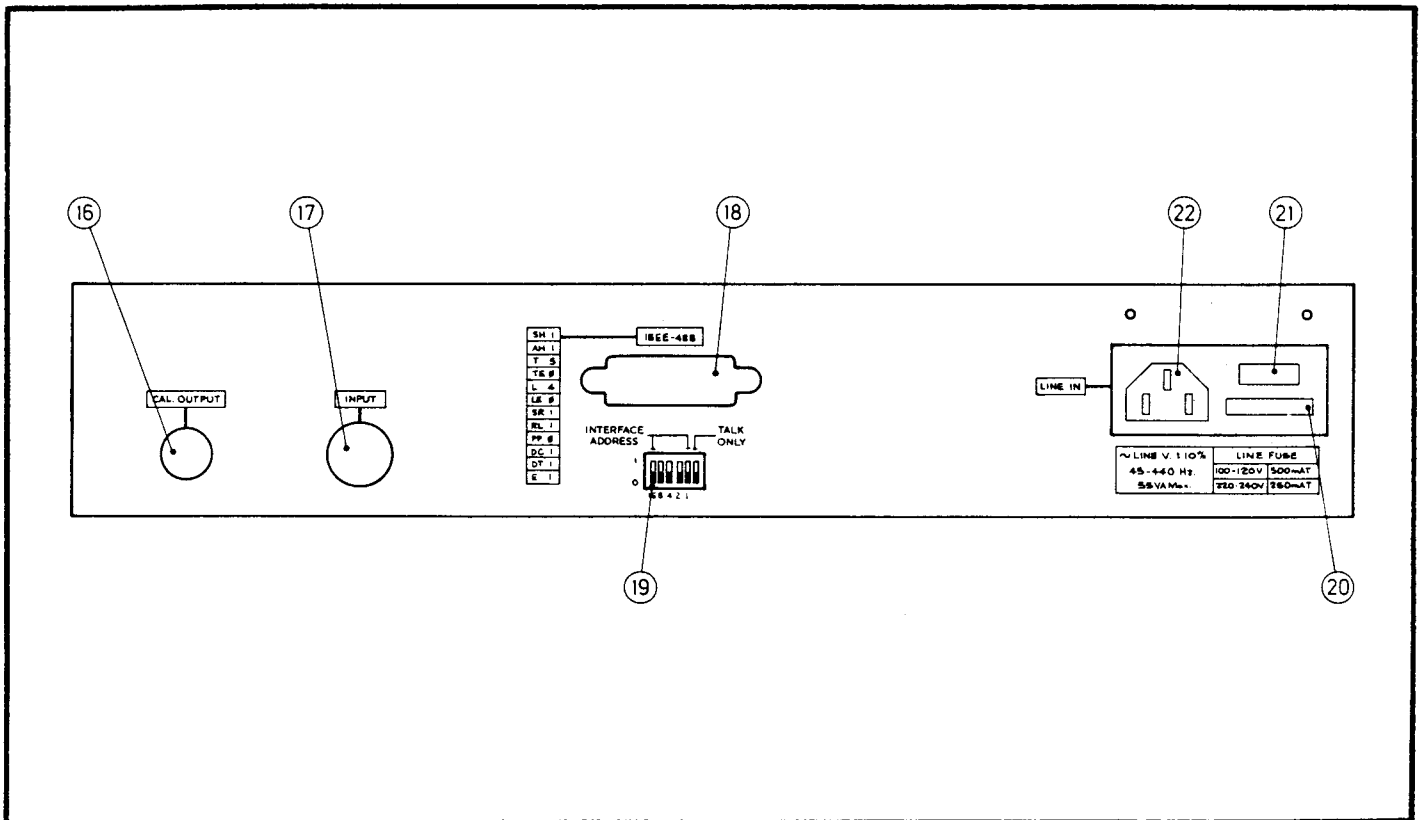

Fig. 4.2 Rear Panel Layout

Cct. Ref.	Value	Description	Rat	Tol %	Racal Part Number
--------------	-------	-------------	-----	----------	----------------------

Connectors

PL4 SK11		Cableform Assembly			10-2701
PL5		PCB header, 7-way			17-1023
PL6		PCB header, 7-way			17-1005
SK7		Receptacle, coaxial			23-3126
SK8		Receptacle, coaxial			23-3126
SK9		Receptacle, coaxial			23-3126
SK10		Receptacle, coaxial			23-3126

### 4.3 SWITCHING ON

4.3.1 The equipment should be prepared for use in accordance with the instructions given in Section 3. If the instrument is being used for the first time, or at a new location, pay particular attention to the setting of the supply voltage range selector. Check that each measuring head is connected to the INPUT socket calibrated for its use.

4.3.2 Connect the instrument to the AC supply, and set the LINE switch to ON. Check that the LINE indicator lights. The front panel indicators will show:

- (a) AUTO mode
- (b) VOLTS measurement function
- (c) FRONT panel INPUT socket selected

The display will show ACAL, to indicate that an automatic internal calibration is being performed.

4.3.3 After approximately 10 seconds the ACAL indication on the display will be removed. Unless inhibited from doing so by the use of SPECIAL FUNCTION 20.2 (see paragraph 4.19) the instrument will carry out further internal calibrations automatically. When this occurs the ACAL indication will reappear in the display.

### 4.4 MEASURING HEAD CALIBRATION

#### 4.4.1 THE FACTORY ECAL

4.4.1.1 The 9303 is supplied with a single measuring head, which bears the same serial number as the instrument. Before despatch the instrument is calibrated to permit this measuring head to be used in either INPUT socket. The resulting external calibration (FACTORY ECAL) factors are stored in the instrument's non-volatile memory, and the factor relating to the INPUT socket selected is enabled at all times when the instrument is in use. It will be necessary to re-calibrate one or both INPUT sockets if an additional or a replacement measuring head is obtained, or if the non-volatile memory contents become corrupted. This may be done with the measuring head connected to the measured signal circuit, or using the special CALIBRATOR outputs on the front and rear panels. For in situ calibration an accurate signal of 223.6 mV, true r.m.s., is required. The head should be terminated with the same load as will be used while measurements are made. If the 9303 CALIBRATOR outputs are to be used, the head should be terminated with the matched load supplied and connected to the appropriate CALIBRATOR socket.

NOTE: The front and rear CALIBRATOR outputs are wired in parallel. The sockets must NOT both be loaded at the same time at any point in the calibration procedure.

Cct. Ref.	Value	Description	Rat	Tol %	Racal Dana Part Number
IC11		78L05			22-4247
IC12		555			22-4206
IC13		74LS221			22-4581
IC14		7407			22-4063
IC15		74LS629			22-4688
IC16		74LS74			22-4534
IC17		TL082			22-4240
IC18		ZN458B			22-4250

### Transistors

Q1		2N4416			22-6040
Q2		BCY71			22-6038
Q3		BC109			22-6041
Q4		BC109			22-6041
Q5		BCY71			22-6038
Q6		BC109			22-6041
Q7		BC109			22-6041
Q8		BCY71			22-6038
Q9		BC109			22-6041
Q10		BC109			22-6041
Q11		BCY71			22-6038
Q12		BC109			22-6041
Q13		BC109			22-6041
Q14		BCY71			22-6038
Q15		2N2369			22-6017
Q16		Not Used			
Q17		BCY71			22-6038
Q18		BCY71			22-6038
Q19		BC109			22-6041
Q20		BCY71			22-6038
Q21		BC109			22-6041
Q22		BCY71			22-6038
Q23		BCY71			22-6038
Q24		BCY71			22-6038
Q25		BCY71			22-6038

#### 4.4.1.2 Using the CALIBRATOR Sockets

- 4.4.1.2.1 When the 9303 CALIBRATOR outputs are used the FACTORY ECAL sequence is started by pressing

/7//0//.//1//SHIFT//SF/.

An ECAL indication will appear in the display. The front measuring head will be calibrated and the FACTORY ECAL factor stored. The CALIBRATOR output will be automatically switched off, and the signal due to noise will be measured and stored. The ECAL indication will disappear when the procedure is complete.

- 4.4.1.2.2 The rear measuring head and CALIBRATOR output are selected by pressing

/REAR/.

The FRONT indicator will be extinguished and the REAR indicator will light. A second FACTORY ECAL cycle is started by pressing

/7//0//.//1//SHIFT//SF/.

- 4.4.1.2.3 If, during the calibration procedure, the ECAL factor measured is outside the range from 0.9 to 1.1, or the measured noise exceeds 300  $\mu$ V, the out of range value will not be stored.

#### 4.4.1.3. Using an External Calibration Source

- 4.4.1.3.1 When using an external calibration source two calibration sequences are required for each measuring head, as the FACTORY ECAL factor and noise must be measured separately. The measurement of the FACTORY ECAL factor must be carried out first.

- 4.4.1.3.2 Connect the measuring head to the calibration source and switch the source on. Press

/7//0//.//1//SHIFT//SF/.

An ECAL indication will appear in the display and the front measuring head FACTORY ECAL factor will be measured and stored. The instrument will then carry out a noise measurement, and, since the calibration source will be switched on, will measure an excessive noise input.

- 4.4.1.3.3 Switch off the calibration source and initiate a second calibration sequence by pressing

/7//0//.//1//SHIFT//SF/.

The ECAL indication will reappear and a second measurement of FACTORY ECAL factor and noise will be made. Since the calibration source is switched off the FACTORY ECAL factor measured will be out of range, and the value measured during the previous calibration cycle will not be over-written.

Cct. Ref.	Value	Description	Rat	Tol %	Racal Dana Part Number
C61		Not Used			
C62	47 $\mu$	Electrolytic	25	20	21-0789
C63	82 p	Ceramic	500	10	21-1519
C64	100 n	Polyester	63	10	21-4565
C65	47 $\mu$	Electrolytic	25	20	21-0789
C66	47 $\mu$	Electrolytic	25	20	21-0789
C67	100 n	Ceramic	12	-20+80	21-1616
C68	47 $\mu$	Electrolytic	25	20	21-0789
C69	100 n	Ceramic	50	20	21-1708
C70	100 n	Ceramic	12	-20+80	21-1616

### Diodes

D1	Voltage Regulator (BZX79C4V7)	22-1807
D2	Silicon (1N4149)	22-1029
D3	Not Used	
D4	Silicon (1N4149)	22-1029
D5	Voltage Regulator (BZX79C5V6)	22-1809
D6	Voltage Regulator (BZX79C7V5)	22-1812
D7	Voltage Regulator (BZX79C7V5)	22-1812
D8	Hot Carrier (5082.2811)	22-1033
D9	Hot Carrier (5082.2811)	22-1033
D10	Hot Carrier (5082.2811)	22-1033
D11	Hot Carrier (5082.2811)	22-1033
D12	Hot Carrier (5082.2811)	22-1033
D13	Hot Carrier (5082.2811)	22-1033

### Integrated Circuits

IC1	TL084	22-4243
IC2	4016	22-4780
IC3	4053	22-4763
IC4	4053	22-4763
IC5	4053	22-4763
IC6	4053	22-4763
IC7	4053	22-4763
IC8	TL082	22-4240
IC9	LM339	22-4249
IC10	LM339	22-4249

The instrument will then measure and store the noise value. Once satisfactory calibration has been achieved the instrument will return to the measurement mode automatically.

4.4.1.3.4 The rear measuring head is calibrated by pressing

/REAR/

and repeating the procedure of paragraphs 4.4.1.3.2 and 4.4.1.3.3.

#### 4.4.2 THE USER ECAL

4.4.2.1 The FACTORY ECAL factor is measured and stored under conditions such that measurements of the specified accuracy will be obtained in a normal working environment over the temperature range from 18°C to 28°C. If the 9303 is to be used in a special environment where this calibration is likely to be invalidated, e.g. at high temperature, an additional USER ECAL factor, for use in that environment only, can be measured and stored. The USER ECAL factor can be enabled and disabled as required, so that the FACTORY ECAL of the instrument for use in a normal environment is not affected.

4.4.2.2 The measurement of the USER ECAL factor may be made with the measuring head connected to the measured signal circuit, or using the special CALIBRATOR outputs on the front and rear panels. For in situ calibration an accurate signal of 223.6 mV, true r.m.s., is required. The head should be terminated with the same load as will be used while measurements are made. If the 9303 CALIBRATOR outputs are to be used the head should be terminated with the matched load supplied and connected to the appropriate CALIBRATOR socket.

NOTE: The front and rear CALIBRATOR outputs are wired in parallel. The sockets must NOT both be loaded at the same time at any point in the calibration procedure.

#### 4.4.2.3 Using the CALIBRATOR Sockets

4.4.2.3.1 When the 9303 CALIBRATOR sockets are used, select FRONT or REAR as appropriate, and press

/STORE//SHIFT//EXT CAL/.

An ECAL indication will appear in the display. A USER ECAL factor for use in the environment in which the procedure is carried out will be measured and stored. The CALIBRATOR output will be automatically switched off and the signal due to noise will be measured and stored. The ECAL indication will disappear and the instrument will return to the measurement mode when measurement and storage are complete. Enable the USER ECAL factor, when required, as instructed in paragraph 4.4.2.5.



Cct. Ref.	Value	Description	Rat	Tol %	Racal Dana Part Number
C21	220 p	Silver Mica	350	1	21-2835
C22	100 p	Ceramic	500	10	21-1520
C23	47 n	Ceramic	12	-20+80	21-1548
C24	47 n	Ceramic	12	-20+80	21-1548
C25	47 n	Ceramic	12	-20+80	21-1548
C26	47 n	Ceramic	12	-20+80	21-1548
C27	10 n	Ceramic	25	-20+80	21-1545
C28	100 n	Polyester	63	10	21-4565
C29	100 n	Polyester	63	10	21-4565
C30	100 n	Polyester	63	10	21-4565
C31	47 $\mu$	Electrolytic	25	20	21-0789
C32	47 n	Ceramic	12	-20+80	21-1548
C33	1.5 n	Silver Mica	350	1	21-2917
C34	100 n	Polyester	63	10	21-4565
C35	47 n	Ceramic	12	-20+80	21-1548
C36	47 $\mu$	Electolytic	25	20	21-0789
C37	100 n	Polyester	63	10	21-4565
C38	47 n	Ceramic	12	-20+80	21-1548
C39	47 n	Ceramic	12	-20+80	21-1548
C40	10 n	Ceramic	25	-20+80	21-1545
C41	47 p	Ceramic	500	10	21-1516
C42	220 p	Silver Mica	350	1	21-2835
C43	22 $\mu$	Tantalum	16	20	21-1039
C44	10 n	Ceramic	25	-20+80	21-1545
C45	47 n	Ceramic	12	-20+80	21-1548
C46	1 n	Silver Mica	200	2	21-3061
C47	47 $\mu$	Electrolytic	25	20	21-0789
C48	47 $\mu$	Electrolytic	25	20	21-0789
C49	100 $\mu$	Electrolytic	25	20	21-0790
C50	47 $\mu$	Electrolytic	25	20	21-0789
C51	47 n	Ceramic	12	-20+80	21-1548
C52	47 n	Ceramic	12	-20+80	21-1548
C53	47 n	Ceramic	12	-20+80	21-1548
C54	10 n	Ceramic	25	-20+80	21-1545
C55	47 $\mu$	Electrolytic	25	20	21-0789
C56	47 n	Ceramic	12	-20+80	21-1548
C57	47 n	Ceramic	12	-20+80	21-1548
C58	47 n	Ceramic	12	-20+80	21-1548
C59	220 n	Polyester	63	10	21-4566
C60	1820 p	Silver Mica	250	1	21-2925

#### 4.4.2.4 Using an External Calibration Source

4.4.2.4.1 When using an external calibrating source two calibration sequences are required for each head, as the USER ECAL factor and the noise must be measured separately. The measurement of the USER ECAL factor must be carried out first.

4.4.2.4.2 Connect the measuring head to the calibration source, select FRONT or REAR as appropriate and switch the source on. Press

/STORE//SHIFT//EXT CAL/.

An ECAL indication will appear in the display and a USER ECAL factor will be measured and stored. The instrument will then carry out a noise measurement, and, since the calibration source is switched on, will indicate excessive noise by means of a flashing Er 15.

4.4.2.4.3 Switch off the calibration source and initiate a second calibration cycle by pressing

/STORE//SHIFT//EXT CAL/.

The ECAL indication will re-appear and a second measurement of USER ECAL factor and noise will be made. Since the calibration source is switched off the USER ECAL measured will be out of range. The value measured on the previous calibration cycle will not be over-written, but at the end of the second cycle the ECAL indication will be replaced by a flashing Er 14. The instrument is returned to the measurement mode by pressing

/CONTINUE/.

Enable the USER ECAL factor, when required, as instructed in paragraph 4.4.2.5.

4.4.2.4.4 If at any time both the USER ECAL factor and the noise measurement are out of range, an Er 16 indication will appear instead of Er 14 or Er 15.

#### 4.4.2.5 USER ECAL Factor Enablement

4.4.2.5.1 The USER ECAL factor is enabled and disabled by successive operations of

/SHIFT//EXT CAL/.

The EXT CAL indicator lights and a CF indicator appears in the display when the factor is enabled.

### 4.5 MEASURING HEAD ATTACHMENTS

#### 4.5.1 50 $\Omega$ ATTENUATORS

4.5.1.1 The calibration of the 9303 may be modified to take account of 50  $\Omega$  attenuators attached to the measuring head. The attenuator should be attached to the measuring head and the head terminated with the matched 50  $\Omega$  termination supplied. A USER ECAL factor and a noise factor are then measured, stored and enabled using the procedures given in paragraph 4.4.2. The maximum value of attenuation for which a USER ECAL factor can be stored is 43 dB.

Cct. Ref.	Value	Description	Rat	Tol %	Racal Dana Part Number
R111	5.6 k	Carbon Film	$\frac{1}{4}$	5	20-2562
R112	2.2 k	Carbon Film	$\frac{1}{4}$	5	20-2222
R113	10	Carbon Film	$\frac{1}{4}$	5	20-2100
R114	3.3 k	Carbon Film	$\frac{1}{4}$	5	20-2332
R115	3.3 k	Carbon Film	$\frac{1}{4}$	5	20-2332
R116	4.7 k	Carbon Film	$\frac{1}{4}$	5	20-2472
R117	680	Metal Film	0.125	1	20-4986
R118	200	Variable			20-7097
R119	1.3 k	Metal Film	0.125	1	20-4988
R120	13 k	Metal Film	0.125	1	20-4992
R121	22 k	Carbon Film	$\frac{1}{4}$	5	20-2223
R122	10 k	Carbon Film	$\frac{1}{4}$	5	20-2103
R123	10 k	Carbon Film	$\frac{1}{4}$	5	20-2103
R124	1 k	Carbon Film	$\frac{1}{4}$	5	20-2102
R125	22 k	Carbon Film	$\frac{1}{4}$	5	20-2223
R126	5.6 k	Carbon Film	$\frac{1}{4}$	5	20-2562

### Capacitors

	<u>F</u>		<u>V</u>		
C1	22 $\mu$	Tantalum	16	20	21-1039
C2	220 p	Silver Mica	350	1	21-2835
C3	2.2 n	Silver Mica	350	1	21-2932
C4	10 $\mu$	Tantalum	25	20	21-1002
C5	47 $\mu$	Electrolytic	25	20	21-0789
C6	10 n	Ceramic	25	-20+80	21-1545
C7	39 p	Ceramic	500	10	21-1515
C8	10 $\mu$	Tantalum	25	20	21-1002
C9	47 $\mu$	Electrolytic	25	20	21-0789
C10	10 n	Ceramic	25	-20+80	21-1545
C11	39 p	Ceramic	500	10	21-1515
C12	10 $\mu$	Tantalum	25	20	21-1002
C13	47 $\mu$	Electrolytic	25	20	21-0789
C14	10 n	Ceramic	25	-20+80	21-1545
C15	47 $\mu$	Electrolytic	25	20	21-0789
C16	10 n	Ceramic	25	-20+80	21-1545
C17	39 p	Ceramic	500	10	21-1515
C18	10 $\mu$	Tantalum	25	20	21-1002
C19	220 p	Silver Mica	350	1	21-2835
C20	100 p	Ceramic	500	10	21-1520

## 4.5.2 SIGNAL AMPLIFIERS

The calibration of the 9303 may be modified to take account of signal amplifiers used in conjunction with the measuring head. The head should be terminated with the matched 50  $\Omega$  load and connected to measure the amplifier output. The amplifier input should be connected to the appropriate CALIBRATOR output using a suitable coaxial connector. A USER ECAL factor and a noise factor are then measured, stored and enabled using the procedures given in paragraph 4.4.2. The maximum amplifier gain for which a USER ECAL factor can be stored is 10 dB.

## 4.5.3 HIGH IMPEDANCE PROBES

4.5.3.1 The calibration may be modified to take account of passive high impedance probes, such as the Racal-Dana model 11-1512, when these are attached to the measuring head. The following procedure should be followed:

- (a) Fit the probe to the measuring head using a BNC to Type N adaptor. Remove the matched 50  $\Omega$  termination from the measuring head.
- (b) Select /FRONT/ or /REAR/ as appropriate and connect the probe tip to the CALIBRATOR socket.

(c) Press        /AUTO//VOLTS//3//0//.//1//SHIFT//SF/.

This will turn on the calibration source.

- (d) Adjust the probe trimmer to obtain the maximum possible reading on the display.

(e) Press        /STORE//dB//dB/.

This will store the reading obtained in (d) in the dB store. The dB computed measuring function will be selected, as indicated by the dB indicator, and the display will indicate 0 dB.

- (f) Adjust the probe trimmer to obtain a reading of -1.2 dB  $\pm$  0.1 dB.

(g) Press        /3//0//.//0//SHIFT//SF/.

This will turn off the calibration source.

(h) Press        /STORE//SHIFT//EXT CAL/.

This will measure and store a USER ECAL factor for the probe. The value is stored separately from the FACTORY ECAL factor for the measuring head, and can be disabled and enabled by means of successive operations of /SHIFT//EXT CAL/. This permits the probe to be detached, if required, without the need to re-calibrate when it is re-attached. When the USER ECAL factor is enabled the EXT CAL indicator lights and a CF indication appears in the display.

Cct. Ref.	Value	Description	Rat	Tol %	Racal Dana Part Number
R71	270	Carbon Film	$\frac{1}{4}$	5	20-2271
R72	1 k	Carbon Film	$\frac{1}{4}$	5	20-2102
R73	1 k	Carbon Film	$\frac{1}{4}$	5	20-2102
R74	18 k	Carbon Film	$\frac{1}{4}$	5	20-2183
R75	2.2 k	Carbon Film	$\frac{1}{4}$	5	20-2222
R76	1 k	Metal Film	0.125	1	20-4987
R77	1 k	Metal Film	0.125	1	20-4987
R78	4.7 k	Carbon Film	$\frac{1}{4}$	5	20-2472
R79	4.7 k	Carbon Film	$\frac{1}{4}$	5	20-2472
R80	100 k	Metal Film	$\frac{1}{4}$	$\frac{1}{2}$	20-4963
R81	100 k	Metal Film	$\frac{1}{4}$	$\frac{1}{2}$	20-4963
R82	16 k	Metal Film	$\frac{1}{4}$	1	20-4889
R83	1 k	Variable			20-7040
R84	4.3 k	Metal Film	0.125	1	20-4990
R85	20.3 k	Metal Film	$\frac{1}{4}$	$\frac{1}{4}$	20-4934
R86	1 k	Variable			20-7040
R87	4.3 k	Metal Film	0.125	1	20-4990
R88	3.3 k	Carbon Film	$\frac{1}{4}$	5	20-2332
R89	100 k	Metal Film	$\frac{1}{4}$	$\frac{1}{2}$	20-4963
R90	100 k	Metal Film	$\frac{1}{4}$	$\frac{1}{2}$	20-4963
R91	49.9	Metal Film	0.125	1	20-4997
R92	4.7 k	Carbon Film	$\frac{1}{4}$	5	20-2472
R93	4.7 k	Carbon Film	$\frac{1}{4}$	5	20-2472
R94	3.3 k	Carbon Film	$\frac{1}{4}$	5	20-2332
R95	1.5 k	Carbon Film	$\frac{1}{4}$	5	20-2152
R96	100	Carbon Film	$\frac{1}{4}$	5	20-2101
R97	100	Carbon Film	$\frac{1}{4}$	5	20-2101
R98	12 k	Carbon Film	$\frac{1}{4}$	5	20-2123
R99	20 k	Variable			20-7090
R100	3.3 k	Carbon Film	$\frac{1}{4}$	5	20-2332
R101	33 k	Carbon Film	$\frac{1}{4}$	5	20-2333
R102	100 k	Carbon Film	$\frac{1}{4}$	5	20-2104
R103	1 k	Carbon Film	$\frac{1}{4}$	5	20-2102
R104	47	Carbon Film	$\frac{1}{4}$	5	20-2470
R105	47	Carbon Film	$\frac{1}{4}$	5	20-2470
R106	390	Carbon Film	$\frac{1}{4}$	5	20-2391
R107	390	Carbon Film	$\frac{1}{4}$	5	20-2391
R108	100	Carbon Film	$\frac{1}{4}$	5	20-2101
R109	100	Carbon Film	$\frac{1}{4}$	5	20-2101
R110	100	Carbon Film	$\frac{1}{4}$	5	20-2101

(j) Press/0//./5//STORE//CAL FACTOR//CAL FACTOR/.

This will store and enable a calibration factor which compensates for the fact that the CALIBRATION socket was not correctly matched during the USER ECAL measurement cycle. When storage is complete the instrument will be returned to the measurement mode with the calibration factor enabled and the probe ready for use. The calibration factor may be disabled and enabled by successive operations of

/CAL FACTOR/.

When the calibration factor is enabled the CAL FACTOR indicator will light.

#### 4.5.4 LOW IMPEDANCE PROBES

4.5.4.1 If a low impedance probe, e.g. Racal-Dana 11-1573 or 11-1574, is used, the calibration procedure given in paragraph 4.5.3.1 should be modified as follows:

- (a) The measuring head must be terminated with the matched 50  $\Omega$  load.
- (b) For probes not fitted with trimmers steps (c) to (g) are omitted.
- (c) The calibration factor stored in step (j) should be calculated from

$$\text{Calibration Factor} = \frac{50 + R_p}{2R_p}$$

where  $R_p$  is the input impedance of the probe/measuring head combination.

#### 4.6 DISPLAY OF ECAL FACTORS

4.6.1 The FACTORY ECAL and USER ECAL factors stored may be displayed by using SPECIAL FUNCTION 40.1 to 40.4 (see paragraph 4.19).

#### 4.7 FREQUENCY RESPONSE

4.7.1 When making high frequency measurements a calibration factor may be entered and stored to take account of the frequency response of the measuring head. Each measuring head is provided with a frequency response curve from which an appropriate calibration factor can be read. If a probe is in use, the calibration factor calculated as instructed in paragraph 4.5.3 should be multiplied by the factor read from the measuring head response curve and the product entered in the CAL FACTOR store.

4.7.2 The calibration factor stored can be displayed by selecting

/FRONT/ or /REAR/

as required, and pressing

/RECALL//CAL FACTOR/.

Cct. Ref.	Value	Description	Rat	Tol %	Racal Dana Part Number
R31	680	Carbon Film	$\frac{1}{4}$	5	20-2681
R32	6.8 k	Carbon Film	$\frac{1}{4}$	5	20-2682
R33	3.3 k	Carbon Film	$\frac{1}{4}$	5	20-2332
R34	2.2 k	Carbon Film	$\frac{1}{4}$	5	20-2222
R35	270	Carbon Film	$\frac{1}{4}$	5	20-2271
R36	200	Variable			20-7097
R37	1.3 k	Metal Film	0.125	1	20-4988
R38	680	Metal Film	0.125	1	20-4986
R39	13 k	Metal Film	0.125	1	20-4992
R40	680	Carbon Film	$\frac{1}{4}$	5	20-2681
R41	6.8 k	Carbon Film	$\frac{1}{4}$	5	20-2682
R42	3.3 k	Carbon Film	$\frac{1}{4}$	5	20-2332
R43	270	Carbon Film	$\frac{1}{4}$	5	20-2271
R44	2.2 k	Carbon Film	$\frac{1}{4}$	5	20-2222
R45	10	Carbon Film	$\frac{1}{4}$	5	20-2100
R46	2.2 k	Carbon Film	$\frac{1}{4}$	5	20-2222
R47	470	Carbon Film	$\frac{1}{4}$	5	20-2471
R48	2.2 k	Carbon Film	$\frac{1}{4}$	5	20-2222
R49	2.2 k	Carbon Film	$\frac{1}{4}$	5	20-2222
R50	470	Carbon Film	$\frac{1}{4}$	5	20-2471
R51	1.5 M	Carbon Film	$\frac{1}{4}$	5	20-2155
R52	1 k	Carbon Film	$\frac{1}{4}$	5	20-2102
R53	4x22 k	DIL Array			20-5527
R54	4x22 k	DIL Array			20-5527
R55	22 k	Carbon Film	$\frac{1}{4}$	5	20-2223
R56	22 k	Carbon Film	$\frac{1}{4}$	5	20-2223
R57	22 k	Carbon Film	$\frac{1}{4}$	5	20-2223
R58	6.8 k	Carbon Film	$\frac{1}{4}$	5	20-2682
R59	22 k	Carbon Film	$\frac{1}{4}$	5	20-2223
R60	22 k	Carbon Film	$\frac{1}{4}$	5	20-2223
R61	22 k	Carbon Film	$\frac{1}{4}$	5	20-2223
R62	22 k	Carbon Film	$\frac{1}{4}$	5	20-2223
R63	1 k	Carbon Film	$\frac{1}{4}$	5	20-2102
R64	22 k	Carbon Film	$\frac{1}{4}$	5	20-2223
R65	100 k	Carbon Film	$\frac{1}{4}$	5	20-2104
R66	390	Carbon Film	$\frac{1}{4}$	5	20-2391
R67	390	Carbon Film	$\frac{1}{4}$	5	20-2391
R68	50 k	Variable			20-7072
R69	100 k	Carbon Film	$\frac{1}{4}$	5	20-2104
R70	1.5 M	Carbon Film	$\frac{1}{4}$	5	20-2155

The RECALL and CAL FACTOR indicators will light as the keys are pressed to indicate that a stored value is being displayed. If no change to the displayed calibration factor is required press

/CONTINUE/.

The RECALL and CAL FACTOR indicators will be extinguished and the instrument will return to the measurement mode. If the factor is to be changed, enter the new factor using the numeric keys. The RECALL and CAL FACTOR indicators will be extinguished when the first numeric key is pressed. When the required factor is correctly displayed, press

/STORE//CAL FACTOR/.

The STORE indicator will light when the key is pressed. It will be extinguished, and the instrument will return to the measurement mode, when the storage of the factor entered is complete.

4.7.3 At any time up to the point where

/CAL FACTOR/

is pressed, the procedure can be aborted by pressing

/CONTINUE/.

The instrument will return to the measurement mode with the calibration factor unchanged.

4.7.4 The calibration factor is enabled and disabled by successive operation of

/CAL FACTOR/.

When enabled, the CAL FACTOR indicator will light and a CF indication will appear in the display.

#### 4.8 SETTING OF AVERAGING TIME

4.8.1 When the equipment is first switched on the averaging time, which sets the display updating rate, is set to 1 second. This can be reset to provide a higher updating rate, or to give a lower updating rate with less jitter. The range of averaging times is from 0.1 second to 99.9 seconds in steps of 0.1 second. A settling time of 3 seconds should be allowed after the application of the signal to be measured irrespective of the averaging time in use.

4.8.2 The averaging time set can be displayed by pressing

/RECALL//SHIFT//AVERAGE/.

The RECALL indicator will light to indicate that a stored value is being displayed. If no change to the averaging time is required, press

/CONTINUE/.



PARTS LIST  
AMPLIFIER ASSEMBLY 19-1016

Fig. 11

Cct. Ref.	Value	Description	Rat	Tol %	Racal Dana Part Number
<u>Resistors</u>					
	<u>Ω</u>		<u>W</u>		
R1	1 k	Carbon Film	$\frac{1}{4}$	5	20-2102
R2	4.7 k	Carbon Film	$\frac{1}{4}$	5	20-2472
R3	10	Carbon Film	$\frac{1}{4}$	5	20-2100
R4	200	Variable			20-7097
R5	1.8 k	Metal Film	0.125	1	20-4989
R6	68	Metal Film	0.125	1	20-4984
R7	680	Metal Film	0.125	1	20-4986
R8	680	Carbon Film	$\frac{1}{4}$	5	20-2681
R9	100	Carbon Film	$\frac{1}{4}$	5	20-2101
R10	6.8 k	Carbon Film	$\frac{1}{4}$	5	20-2682
R11	100	Carbon Film	$\frac{1}{4}$	5	20-2101
R12	10	Carbon Film	$\frac{1}{4}$	5	20-2100
R13	2.2 k	Carbon Film	$\frac{1}{4}$	5	20-2222
R14	1 k	Carbon Film	$\frac{1}{4}$	5	20-2102
R15	270	Carbon Film	$\frac{1}{4}$	5	20-2271
R16	200	Variable			20-7097
R17	1.8 k	Metal Film	0.125	1	20-4989
R18	68	Metal Film	0.125	1	20-4984
R19	680	Metal Film	0.125	1	40-4986
R20	680	Carbon Film	$\frac{1}{4}$	5	20-2681
R21	6.8 k	Carbon Film	$\frac{1}{4}$	5	20-2682
R22	1 k	Carbon Film	$\frac{1}{4}$	5	20-2102
R23	2.2 k	Carbon Film	$\frac{1}{4}$	5	20-2222
R24	270	Carbon Film	$\frac{1}{4}$	5	20-2271
R25	10	Carbon Film	$\frac{1}{4}$	5	20-2100
R26	200	Variable			20-7097
R27	1.8 k	Metal Film	0.125	1	20-4989
R28	220	Metal Film	0.125	1	20-4985
R29	5.6 k	Metal Film	0.125	1	20-4991
R30	100	Carbon Film	$\frac{1}{4}$	5	20-2101

The RECALL indicator will be extinguished and the instrument will return to the measurement mode. If the averaging time is to be reset, set the required value on the display, using the numeric keys. The RECALL indicator will be extinguished when the first numeric key is pressed. When the required averaging time is correctly set, press

/STORE//SHIFT//AVERAGE/.

The STORE indicator will light when the key is pressed. It will be extinguished, and the instrument will return to the measurement mode, when the storage of the new value is complete.

4.8.3 At any time up to the point where

/AVERAGE/

is pressed, the procedure can be aborted by pressing

/CONTINUE/.

The instrument will return to the measurement mode with the averaging time unchanged.

#### 4.9 CONTINUOUS AVERAGING MODE

4.9.1 The use of this mode avoids the low display updating rates which are caused by the use of long averaging times. The display is updated every 0.1 second to a value obtained partly from the current displayed value and partly from the new measured value. The overall effect is similar to that which would be obtained if successive measured values were filtered in a single pole RC filter.

4.9.2 The continuous averaging mode is enabled and disabled using SPECIAL FUNCTIONS 50.1 and 50.0 (see paragraph 4.19). The time constant of the effective filter will be the value set in the AVERAGE store. This value may be viewed, and, if required, changed, using the procedure given in paragraphs 4.8.2 and 4.8.3.

4.9.3 The mode is automatically disabled during any measurement cycle in which the current displayed value and the new measured value differ by more than 5%. This results in a rapid change of the displayed value in response to large step changes of input level.

#### 4.10 RANGING MODE SETTING

4.10.1 On switching on, the instrument will be set to the auto-ranging mode. To put the instrument into the manual ranging mode without changing the range in use, press the AUTO/MANUAL key. This key selects manual ranging and auto-ranging on successive operations. The indicator for the mode in use will light. The instrument may be switched from the auto-ranging mode to the manual ranging mode, accompanied by a change to an adjacent range, by means of the STEP UP or STEP DOWN key. When manual ranging is selected an analogue indication of the measured signal as a fraction of full scale appears in the display.

4.10.2 When in the manual ranging mode the range in use may be changed by pressing

/STEP UP/ or /STEP DOWN/.

The full scale value for the range in use can be displayed by pressing

/RECALL//SHIFT//RANGE/.

The RECALL indicator will light when the key is pressed. To return the instrument to the measurement mode, press

/CONTINUE/.

4.10.3 If the input signal is outside the limits of 10% and 110% of full scale of the range in use, the display will alternate between the measured value and an under-range (Ur) or over-range (Or) indication. When in the auto-ranging mode a range change will occur if the input signal is outside the limits of 27% and 110% of full scale, so that error indications are obtained on the highest and lowest ranges only.

#### 4.11 VOLTAGE PRIMARY MEASUREMENT FUNCTION

4.11.1 When first switched on the instrument will be set to the voltage measuring function. If the instrument has been in use and is set for some other measuring function, press

/VOLTS/.

The VOLTS indicator will light.

#### 4.12 POWER PRIMARY MEASUREMENT FUNCTION

4.12.1 The 9303 measures in voltage units, but can convert measurements made into power units by squaring the measured voltage and dividing by the resistance value held in the  $\Omega$  store. To select the power measuring function, press

/WATTS/.

The WATTS indicator will light.

4.12.2 The value in the  $\Omega$  store will be set to 50  $\Omega$  on switching on. The number in the store can be displayed by pressing

/RECALL//SHIFT// $\Omega$ /.

The RECALL indicator will light when the key is pressed to show that a stored value is being displayed.

4.12.3 If no change to the resistance value is required, press

/CONTINUE/.

Cct. Ref.	Value	Description	Rat	Tol %	Racal Dana Part Number
<u>Diodes</u>					
D1		Silicon (1N4149)			22-1029
D2		Not Used			
D3		Voltage Regulator (BZY88C4V7)			22-1807
D4		Hot Carrier (5082.2811)			22-1033
D5		Hot Carrier (5082.2811)			22-1033
D6		Silicon (1N4149)			22-1029
D7		Silicon (1N4149)			22-1029
D8		Silicon (1N4149)			22-1029
D9		Silicon (1N4149)			22-1029
D10		Silicon (1N4149)			22-1029
D11		Silicon (1N4149)			22-1029
D12		Silicon (1N4149)			22-1029
<u>Integrated Circuits</u>					
IC1		TL084			22-4243
IC2		4017			22-4706
IC3		TL081			22-4229
IC4		TL084			22-4243
IC5		CA3046 (specially selected)			22-4246
IC6		CA3046 (specially selected)			22-4246
IC7		CA3046 (specially selected)			22-4246
<u>Transistors</u>					
Q1		J305			22-6141
Q2		Not Used			
Q3		J305			22-6141
Q4		J305			22-6141
Q5		J305			22-6141
Q6		J176			22-6140
Q7		2N4416			22-6092
Q8		2N4416			22-6092
Q9		J305			22-6141
Q10		2N4416			22-6092
<u>Connectors</u>					
PL11		PCB header, 20-way			23-3317

The RECALL indicator will be extinguished, and the instrument will return to the measurement mode. If the resistance value is to be changed, set the required value on the display, using the numeric keys, followed by

/SHIFT// $\Omega$ /.

The RECALL indicator will be extinguished when the first numeric key is pressed. When the required resistance value is set, press

/STORE//SHIFT// $\Omega$ /.

The STORE indicator will light when the key is pressed. It will be extinguished, and the instrument will return to the measurement mode, when the storage of the new value is complete.

4.12.4 At any time up to the point where

/ $\Omega$ /

is pressed, the procedure can be aborted by pressing

/CONTINUE/.

The instrument will return to the measurement mode with the resistance value unchanged.

NOTE: The values held in the %, RATIO, NULL and dB stores are in voltage units. The values may have been computed from keyboard inputs or displayed power measurements, using the resistance value in the  $\Omega$  store at the time of entry. These values are NOT automatically updated when the resistance value in the  $\Omega$  store is changed.

#### 4.13 RATIO MEASUREMENTS

4.13.1 With the ratio function selected the instrument computes

measured voltage

---

voltage value held in ratio store

To select the ratio function, press

/RATIO/.

The RATIO indicator will light. Note that the display will indicate a ratio of voltages or powers according to whether the voltage or power measuring function is selected. The conversion to power units uses the current resistance value in the  $\Omega$  store.

4.13.2 When the instrument is first switched on the RATIO store will be loaded with 1 volt. The value in the store can be displayed by pressing.

/RECALL//RATIO/.

The RECALL indicator will light when the key is pressed to show that a stored value is being displayed. The displayed value will be in voltage or power units, according to the measuring function selected.

Cct. Ref.	Value	Description	Rat	Tol %	Racal Dana Part Number
R36	7x100 k	DIL Array			20-5504
R37	7x10 k	DIL Array			20-5517
R38	12 k	Carbon Film	$\frac{1}{4}$	5	20-2123
R39	1 k	Carbon Film	$\frac{1}{4}$	5	20-2102
R40	100 k	Metal Film	$\frac{1}{4}$	$\frac{1}{2}$	20-4963
R41	49.9 k	Metal Film	$\frac{1}{4}$	$\frac{1}{2}$	20-4958
R42	330 k	Carbon Film	$\frac{1}{4}$	5	20-2334
R43	10 M	Carbon Film	$\frac{1}{4}$	10	20-2106
R44	150 k	Carbon Film	$\frac{1}{4}$	5	20-2154
R45	150 k	Carbon Film	$\frac{1}{4}$	5	20-2154
R46	220 k	Carbon Film	$\frac{1}{4}$	5	20-2224
R47	150 k	Carbon Film	$\frac{1}{4}$	5	20-2154
R48	150 k	Carbon Film	$\frac{1}{4}$	5	20-2154

### Capacitors

	<u>F</u>		<u>V</u>		
C1	10 n	Ceramic	25	-20 +80	21-1545
C2	220 $\mu$	Electrolytic	16	-10 +50	21-0627
C3	10 n	Ceramic	25	-20 +80	21-1545
C4	220 $\mu$	Electrolytic	16	-10 +50	21-0627
C5	100 p	Ceramic	500	10	21-1520
C6	1 $\mu$	Electrolytic	40	-20 +80	21-0731
C7	10 n	Ceramic	25	-20 +80	21-1545
C8	10 n	Ceramic	25	-20 +80	21-1545
C9	10 n	Ceramic	25	-20 +80	21-1545
C10	10 n	Ceramic	25	-20 +80	21-1545
C11	47 $\mu$	Electrolytic	25	20	21-0789
C12	2.7 n	Ceramic	500	20	21-1537
C13	150 n	Polyester	63	5	21-4564
C14	2.7 n	Ceramic	500	20	21-1537
C15	10 n	Ceramic	25	-20 +80	21-1545
C16	10 n	Ceramic	25	-20 +80	21-1545
C17	10 n	Ceramic	25	-20 +80	21-1545
C18	1 $\mu$	Polycarbonate	100	20	21-5507
C19	10 n	Ceramic	25	-20 +80	21-1545
C20	100 n	Polycarbonate	100	20	21-5501
C21	10 n	Ceramic	25	-20 +80	21-1545
C22	10 p	Ceramic	500	10	21-1508
C23	1 $\mu$	Polyester	100	20	21-4512
C24	220 n	Polycarbonate	100	20	21-5503
C25	100 n	Polyester	63	10	21-4565

4.13.3 If no change to the stored level is required press

/CONTINUE/.

The RECALL indicator will be extinguished, and the instrument will return to the measurement mode.

4.13.4 If the stored value is to be reset to a specified figure, set the required value on the display using the numeric keys. The RECALL indicator will be extinguished when the first numeric key is pressed. The value set on the display may be in voltage or power units. When the required digits have been set, press

/SHIFT//APPROPRIATE UNITS//STORE//RATIO/.

The appropriate display annunciator will light when the units are entered. The STORE indicator will light when the key is pressed. It will be extinguished, and the instrument will return to the measurement mode, when the storage of the new value is complete.

4.13.5 The RATIO store may also be reset to the current displayed value when voltage or power measurements are being made. To reset the stored value to the current displayed value, press

/STORE//RATIO/.

The STORE indicator will light when the key is pressed, and will be extinguished when the storage of the new value is completed.

4.13.6 At any time up to the point where

/RATIO/

is pressed either store updating procedure can be aborted by pressing

/CONTINUE/.

#### 4.14 PERCENTAGE DIFFERENCE MEASUREMENTS

4.14.1 With the percentage difference function selected the instrument computes

$$\frac{\text{measured voltage} - \text{voltage value in \% store}}{\text{voltage value in \% store}} \times 100$$

To select the percentage difference function, press

/%/.

The % indicator will light. Note that the display will indicate a percentage difference of voltages or powers according to whether the voltage or power measuring function is selected. The conversion to power units uses the current resistance value in the  $\Omega$  store.

PARTS LIST

SIGNAL CONVERTER ASSEMBLY 19-1015

Fig. 9

Cct. Ref.	Value	Description	Rat	Tol %	Racal Dana Part Number
<u>Resistors</u>					
	<u>Ω</u>		<u>W</u>		
R1	1 k	Carbon Film	$\frac{1}{4}$	5	20-2102
R2	1 k	Carbon Film	$\frac{1}{4}$	5	20-2102
R3	150 k	Carbon Film	$\frac{1}{4}$	5	20-2154
R4		Not Used			
R5		Not Used			
R6	100 k	Carbon Film	$\frac{1}{4}$	5	20-2104
R7		Not Used			
R8	470	Carbon Film	$\frac{1}{4}$	5	20-2471
R9	10 k	Carbon Film	$\frac{1}{4}$	5	20-2103
R10	500	Metal Film	$\frac{1}{4}$	$\frac{1}{2}$	20-4879
R11	1 k	Carbon Film	$\frac{1}{4}$	5	20-2102
R12	1.2 k	Metal Film	$\frac{1}{4}$	$\frac{1}{2}$	20-4922
R13	1.2 k	Metal Film	$\frac{1}{4}$	$\frac{1}{2}$	20-4922
R14	68 k	Carbon Film	$\frac{1}{4}$	5	20-2683
R15	1.2 k	Metal Film	$\frac{1}{4}$	$\frac{1}{2}$	20-4922
R16	22 k	Carbon Film	$\frac{1}{4}$	5	20-2223
R17	68 k	Carbon Film	$\frac{1}{4}$	5	20-2683
R18	1.2 k	Metal Film	$\frac{1}{4}$	$\frac{1}{2}$	20-4922
R19	22 k	Carbon Film	$\frac{1}{4}$	5	20-2223
R20	22 k	Carbon Film	$\frac{1}{4}$	5	20-2223
R21	22 k	Carbon Film	$\frac{1}{4}$	5	20-2223
R22	47 k	Carbon Film	$\frac{1}{4}$	5	20-2473
R23	470 k	Carbon Film	$\frac{1}{4}$	5	20-2474
R24	50 k	Variable			20-7072
R25	1 k	Metal Film	$\frac{1}{4}$	$\frac{1}{2}$	20-4921
R26	1 k	Metal Film	$\frac{1}{4}$	$\frac{1}{2}$	20-4921
R27	10 k	Carbon Film	$\frac{1}{4}$	5	20-2103
R28	1 k	Carbon Film	$\frac{1}{4}$	5	20-2102
R29	220 k	Carbon Film	$\frac{1}{4}$	5	20-2224
R30	1 k	Carbon Film	$\frac{1}{4}$	5	20-2102
R31	220 k	Carbon Film	$\frac{1}{4}$	5	20-2224
R32	49.9 k	Metal Film	$\frac{1}{4}$	$\frac{1}{2}$	20-4958
R33	49.9 k	Metal Film	$\frac{1}{4}$	$\frac{1}{2}$	20-4958
R34	12.4 k	Metal Film	$\frac{1}{4}$	$\frac{1}{4}$	20-4927
R35	12.4 k	Metal Film	$\frac{1}{4}$	$\frac{1}{4}$	20-4927



4.14.2 When the instrument is first switched on the percent store will be loaded with 1 volt. The value in the store can be displayed and, if necessary, changed using the same procedures as those described for the ratio store. The keyboard address of the percent store is

/%/.

#### 4.15 NULL MEASUREMENTS

4.15.1 With the null function selected the instrument computes  
measured voltage - voltage value in null store.

To select the null function, press

/NULL/.

The NULL indicator will light. The current displayed value will be entered into the NULL store, and the display will indicate zero. When the input level is changed the display will indicate a difference of voltages or powers according to whether the voltage or power measuring function is selected. The conversion to power units uses the current resistance value in the  $\Omega$  store.

4.15.2 When the null function is selected the contents of the NULL store can be displayed and, if required, changed using the same procedures as those described for the ratio store. This allows the difference between the measured value and an operator set value to be displayed. The keyboard address of the NULL store is

/NULL/

Note that, if the instrument leaves and re-enters the null measurement function, the value in the NULL store will be over-written with the measured value current when the mode is re-entered.

#### 4.16 dB MEASUREMENTS

4.16.1 With the dB function selected the instrument computes

$$20 \log \frac{\text{measured volts}}{\text{voltage value in dB store}}$$

The calculation does not involve the resistance value held in the  $\Omega$  store. However, if the voltage value in the dB store and the resistance value in the  $\Omega$  store represent a power of 1 mW, the display units annunciator will indicate dBm. To select the dB function, press

/dB/.

The dB indicator will light.

Cct. Ref.	Value	Description	Rat	Tol %	Racal Part Number
--------------	-------	-------------	-----	----------	----------------------

Inductors

	<u>H</u>			
L1	100 $\mu$	Choke, RF		23-7056

Connectors

SK3		Cable Assembly		10-2871
PL15		PCB header, 20-way		23-3319
PL13		PCB header, 34-way		23-3325

Miscellaneous

FS1		Fuse link, 1.6 A		23-0055
		Holder for FS1		23-0054
		Lithium Battery		23-2513
S30		Switch, DIL		23-4089
S29		Switch, with flexible extension		23-4104
		Knob for S29		23-9098

4.16.2 When the instrument is first switched on the dB store will be loaded with 223.6 mV. The value in the store can be displayed and, if necessary, changed using the same procedures as those described for the ratio store. The keyboard address of the dB store is

/dB/.

#### 4.17 ANALOGUE DISPLAY

4.17.1 The analogue display will be found to be particularly useful for obtaining peak or trough indications but may be used with all the measurement functions. The display is switched on and off by successive operations of

/METER/.

The coarse part of the display is automatically switched on when the manual ranging mode is selected. To obtain the full display press

/METER//METER/.

#### 4.18 STORAGE OF FRONT PANEL SETTINGS

4.18.1 Up to 12 complete sets of front panel settings may be stored for later recall. The settings stored are:

- (a) Primary measurement function
- (b) Computed measurement function
- (c) Measurement range
- (d) Ranging mode
- (e) Contents of  $\Omega$ , RATIO, %, NULL and dB stores
- (f) User ECAL factors
- (g) User ECAL factor enablement
- (h) Calibration factors
- (j) Calibration factor enablement
- (k) Averaging period
- (l) Measuring head selected

Each set of front panel settings should be allocated a numeric address in the range 01 to 12. To store the front panel settings, press

/STORE//DIGIT\*//DIGIT\*/.

\* of the allocated address

Note that the leading zero must be entered for addresses 01 to 09. The STORE indicator will light when the key is pressed. It will be extinguished, and the instrument will return to the measurement mode with panel settings unchanged, when storage is completed.

Cct. Ref.	Value	Description	Rat	Tol %	Racal Dana Part Number
IC16		2732 (programmed)	22-8570	22-8540	22-8515
IC17		2732 (programmed)	22-8569	22-8539	22-8514
IC18		2732 (programmed)	22-8568	22-8538	22-8513
IC19		2732 (programmed)	22-8567	22-8537	22-8512
IC20		6514-9			22-8204

Note: When ordering replacements for IC's 16, 17, 18 and 19 the software issue number and the instrument serial number must be quoted in addition to the part number. The software issue number is marked on the component. Each column of part numbers forms a hardware compatible set. The ROMs fitted must all be from the same set, and be of the same software issue.

IC21		6514-9			22-8204 or 22-8205
IC22		74LS245			22-4584
IC23		74LS244			22-4583
IC24		74LS244			22-4583
IC25		74LS138			22-4587
IC26		74LS139			22-4678
IC27		74LS30			22-4597
IC28		74LS240			22-4588
IC29		74LS240			22-4588
IC30		6802			22-8302
IC31		74LS74			22-4534
IC32		74LS138			22-4587
IC33		7407			22-4063
IC34		74LS138			22-4587
IC35		74LS00			22-4531
IC36		74LS04			22-4533
IC37		74LS09			22-4596
IC38		79MGU1C			22-4261
IC39		78MGU1C			22-4260
IC40		ZN458B			22-4250
IC41		Not Used			
IC42		74HC00			22-4775
IC43		74HC4075			22-4776
IC44		7705			22-4267
IC45		3078E			22-4268

#### Transistors

Q1		BC109			22-6041
Q2		ZTX450			22-6112

4.18.2 The front panel settings can be recalled by pressing

/RECALL//DIGIT\*//DIGIT\*/.

\* of the allocated address

The RECALL indicator will light when the key is pressed. It will be extinguished, and the instrument will be reset to the measurement mode with the recalled front panel settings, when the recall is complete. The pressing of

/RECALL//0//0/

will recall the switch-on state (initialisation) settings. The stored front panel settings are not lost on recall, so that stored patterns may be recalled as often as required. Individual settings in the stored pattern cannot be amended, so changes must be made by over-writing the stored pattern with a complete, revised pattern.

4.18.3 When the power to the instrument is switched off the front panel settings are automatically stored. They can be recalled immediately after switching on again by pressing

/RECALL//9//9/.

The first change of front panel settings after switching on overwrites the data stored in location 99. The facility of recalling the settings in use when the instrument was switched off is then lost.

#### 4.19 SPECIAL FUNCTIONS

4.19.1 A number of special functions are available to the operator. These are listed in Table 4.1, and are called by pressing

/MSD\*//DIGIT//.//LSD\*//SHIFT//SF/.

\* of the special function number

#### 4.20 ERROR CODES

4.20.1 The instrument is able to detect a number of error states, some of which are indicated on the display. The meanings of the error codes are given in Table 4.2.

Cct. Ref.	Value	Description	Rat	Tol %	Rca1 Dana Part Number
<u>Diodes</u>					
D1		Bridge Rectifier (VH 248)			22-1662
D2		Silicon (1N4003)			22-1603
D3		Silicon (1N4003)			22-1603
D4		Silicon (1N4003)			22-1603
D5		Silicon (1N4003)			22-1603
D6		Silicon (1N4003)			22-1603
D7		Silicon (1N4003)			22-1603
D8		Silicon (1N4003)			22-1603
D9		Silicon (1N4003)			22-1603
D10		Silicon (1N4003)			22-1603
D11		Silicon (1N4003)			22-1603
D12		Voltage Regulator (BZY88C5V6)			22-1809
D13		Hot Carrier (5082.2811)			22-1033
D14		Voltage Regulator (BZX79C5V6)			22-1809
D15		Voltage Regulator (BZX79C5V6)			22-1809
D16		Voltage Regulator (BZX79C10)			22-1815
D17		Hot Carrier (5082.2800)			22-1068
D18		Not Used			
D19		Silicon (1N4149)			22-1029
D20		Silicon (1N4149)			22-1029

Integrated Circuits

IC1		Not Used			
IC2		Not Used			
IC3		LM339			22-4249
IC4		LM339			22-4249
IC5		LM339			22-4249
IC6		LM339			22-4249
IC7		LM339			22-4249
IC8		4066			22-4761
IC9		8750J			22-4594
IC10		Not Used			
IC11		6821			22-8303
IC12		6821			22-8303
IC13		74LS14			22-4570
IC14		74LS123			22-4547
IC15		74HC00			22-4775

TABLE 4.1

Special Functions

Special Function Number	Function
0	Cancels all special functions.
20.0	Allows timed, automatic internal calibrations (ACAL).
20.1	Initiates an immediate ACAL.
20.2	Inhibits automatic ACAL.
30.0	Switches off external calibrator.
30.1	Turns on external calibrator.
40.0	Displays ACAL factor.
40.1	Displays USER ECAL factor.
40.2	Displays USER ECAL noise cancellation factor.
40.3	Displays FACTORY ECAL factor.
40.4	Displays FACTORY ECAL noise cancellation factor.
<p>Note: (1) To return to the measurement mode press /CONTINUE/.</p> <p>(2) The ECAL and noise cancellation factors displayed relate to the measuring head selected.</p>	
50.0	Selects the fixed average mode.
50.1	Selects the continuous average mode.
70.1	Initiates FACTORY ECAL cycle.
80.0	Allows over range (Or) and under range (Ur) indication.
80.1	Inhibits Or and Ur indication.
81.0	Displays software issue number
<p>Note: (1) To return to the measurement mode press /CONTINUE/.</p> <p>(2) The software issue number is displayed in the format  XY.Z  The number XY is the last two digits of the Racal-Dana part number of one of the ROMs fitted, and identifies the hardware compatible set in use. The number Z is the issue number. (Early model instruments display the number Z only).</p>	

Cct. Ref.	Value	Description	Rat	Tol %	Racal Dana Part Number
C16	10 n	Ceramic	25	-20 +80	21-1545
C17	22 $\mu$	Electrolytic	10		21-0710
C18	100 n	Ceramic	25	-20 +80	21-1551
C19	47 n	Ceramic	12	-20 +80	21-1548
C20	100 n	Ceramic	25	-20 +80	21-1551
C21	10 n	Ceramic	25	-20 +80	21-1545
C22	100 n	Ceramic	25	-20 +80	21-1551
C23	100 n	Ceramic	25	-20 +80	21-1551
C24	10 n	Ceramic	25	-20 +80	21-1545
C25	10 n	Ceramic	25	-20 +80	21-1545
C26	68 p	Silver Mica	350	2	21-2643
C27	270 p	Ceramic	500	10	21-1525
C28	47 n	Ceramic	12	-20 +80	21-1548
C29	47 n	Ceramic	12	-20 +80	21-1548
C30	330 p	Ceramic	500	10	21-1526
C31	47 n	Ceramic	12	-20 +80	21-1548
C32	47 n	Ceramic	12	-20 +80	21-1548
C33	47 n	Ceramic	12	-20 +80	21-1548
C34	47 n	Ceramic	12	-20 +80	21-1548
C35	47 n	Ceramic	12	-20 +80	21-1548
C36	47 n	Ceramic	12	-20 +80	21-1548
C37	47 n	Ceramic	12	-20 +80	21-1548
C38	100 n	Ceramic	25	-20 +80	21-1551
C39	47 n	Ceramic	12	-20 +80	21-1548
C40	47 n	Ceramic	12	-20 +80	21-1548
C41	47 n	Ceramic	12	-20 +80	21-1548
C42	47 $\mu$	Electrolytic	25	20	21-0789
C43	47 n	Ceramic	12	-20 +80	21-1548
C44	47 n	Ceramic	12	-20 +80	21-1548
C45	47 n	Ceramic	12	-20 +80	21-1548
C46	27 p	Ceramic	500	10	21-1513
C47	27 p	Ceramic	500	10	21-1513
C48	47 n	Ceramic	12	-20 +80	21-1548
C49	100 n	Ceramic	25	-20 +80	21-1551
C50		Not Used			
C51	10 n	Ceramic	25	-20 +80	21-1545
C52	4.7 n	Paper	250		21-0004
C53	4.7 n	Paper	250		21-0004
C54	100 n	Ceramic	25	-20 +80	21-1551



TABLE 4.2

Error Codes

Error	Error Code
Non-Volatile memory contents corrupted	01
Over range signal	02
Under range signal	03
Computed result to be displayed exceeds display capacity	11
Number entered to be stored has incorrect format	12
Zero entered as a number to be stored	13
Measuring head USER ECAL factor outside allowed range	14
Noise measured during USER ECAL outside allowed range	15
Both noise and USER ECAL factor outside allowed range	16
Stored noise value more than 20 $\mu$ V greater than input	17
GPIB syntax error	18
RAM failure	20
ROM failure, IC16 on 19-1014	23
ROM failure, IC17 on 19-1014	24
ROM failure, IC18 on 19-1014	25
ROM failure, IC19 on 19-1014	26

Note: (1) Errors 02 and 03 are displayed as Or and Ur. Error 18 is not displayed. The other errors displayed appear as Er followed by two digits.

(2) When Error 01 is detected, nominal values are entered in the FACTORY ECAL, USER ECAL and CALIBRATION FACTOR memory locations. The display will flash Error 01, and the EXT CAL indicator will flash to indicate that the FACTORY ECAL factor stored is not valid. To return the instrument to an operational state, carry out the FACTORY ECAL procedure given in paragraph 4.4.1 in respect of both INPUT sockets.

(3) When Error 01 is detected the switch-on state front panel settings are entered into memory locations 01 to 12.

Cct. Ref.	Value	Description	Rat	Tol %	Racal Dana Part Number
R31	2.2 k	Carbon Film	$\frac{1}{4}$	5	20-2222
R32	4.7 k	Carbon Film	$\frac{1}{4}$	5	20-2472
R33	8x3.3 k	DIL Array			20-5525
R34	8x3.3 k	DIL Array			20-5525
R35	8x3.3 k	DIL Array			20-5525
R36	3.3 M	Carbon Film	$\frac{1}{4}$	5	20-2335
R37	2.2 k	Carbon Film	$\frac{1}{4}$	5	20-2222
R38	10 k	Carbon Film	$\frac{1}{4}$	5	20-2103
R39	820	Carbon Film	$\frac{1}{4}$	5	20-2821
R40	10	Carbon Film	$\frac{1}{4}$	5	20-2100
R41	1 k	Carbon Film	$\frac{1}{4}$	5	20-2102
R42	10 k	Carbon Film	$\frac{1}{4}$	5	20-2103
R43	10 k	Carbon Film	$\frac{1}{4}$	5	20-2103
R44	1 k	Variable, 25-turn			20-7040
R45	3.9 k	Metal Film	$\frac{1}{4}$	1	20-7515
R46	2.2 k	Metal Film	$\frac{1}{4}$	1	20-7514
R47	820	Metal Film	$\frac{1}{4}$	1	20-7513
R48	4.3 k	Metal Film	$\frac{1}{4}$	1	20-4990
R49	1 k	Variable, 25-turn			20-7040
R50	2.2 k	Carbon Film	$\frac{1}{4}$	5	20-2222
R51	9x10 k	DIL Array			20-5521
R52	9x10 k	DIL Array			20-5521
R53	3.3 k	Carbon Film	$\frac{1}{4}$	5	20-2332
R54	3.3 k	Carbon Film	$\frac{1}{4}$	5	20-2332
R55	3.3 k	Carbon Film	$\frac{1}{4}$	5	20-2332

### Capacitors

	<u>F</u>		<u>V</u>	
C1	22000 $\mu$	Electrolytic	16	21-0595
C2	3300 $\mu$	Electrolytic	35	21-0663
C3	3300 $\mu$	Electrolytic	35	21-0663
C4	3300 $\mu$	Electrolytic	16	21-0597
C5	47 n	Ceramic	12	-20 +80 21-1548
C6	47 n	Ceramic	12	-20 +80 21-1548
C7	100 n	Ceramic	25	-20 +80 21-1551
C8	100 n	Ceramic	25	-20 +80 21-1551
C9	47 n	Ceramic	25	20 21-0789
C10	47 n	Ceramic	25	20 21-0789
C11	47 n	Ceramic	25	20 21-0789
C12	47 n	Ceramic	25	20 21-0789
C13	47 n	Ceramic	25	20 21-0789
C14	47 n	Ceramic	12	-20 +80 21-1548
C15	47 n	Ceramic	12	-20 +80 21-1548

## 4.21 CONTROL VIA THE GPIB

- 4.21.1 The 9303 can be operated via the GPIB in either the addressed mode or the talk only mode. In the former the instrument makes measurements in response to commands, prefaced by the instrument's listen address, sent via the bus by the controller. The last measured value is loaded onto the bus when the instrument is addressed to talk.
- 4.21.2 In the talk only mode the 9303 will take measurements continually, at a rate determined by the averaging time in use, in accordance with instructions entered using the front panel controls. At the end of each measurement cycle the measured value is entered into a buffer store, from where it is loaded onto the bus in response to a signal on the NRFD line (commencement of the handshake sequence). If a measurement cycle is completed while data transfer is in progress, the updating of the buffer store is delayed until the data transfer is completed.

## 4.22 REMOTE/LOCAL CHANGEOVER

### 4.22.1 LOCAL TO REMOTE CONTROL CHANGEOVER

- 4.22.1.1 The 9303 is switched from local to remote control by the following sequence of control and data line messages:

- (a) Remote enable (REN) true (low) This primes the remote control enable, but the 9303 remains in local control. REN must remain true if any instrument on the bus is to remain in remote control.
- (b) Attention (ATN) true (low)
- (c) Listen address The 9303 enters the listener addressed state (LADS) on recognition of its listen address.
- (d) ATN false (high) The 9303 enters the listener active state (LACS) after a delay, and enters the remote state (REMS) on receipt of the first data byte.

- 4.22.1.2 No change to any of the 9303 control settings occurs on changeover from local to remote control.

### 4.22.2 REMOTE TO LOCAL CONTROL CHANGEOVER

- 4.22.2.1 The 9303 will be switched from remote to local control on:

- (a) Operation of the front panel LOCAL key. This is effective only if local lockout is not set.

PARTS LIST

PROCESSOR ASSEMBLY 19-1014

Fig. 7

Cct. Ref.	Value	Description	Rat	Tol %	Racal Dana Part Number
<u>Resistors</u>					
	<u>Ω</u>		<u>W</u>		
R1	3.3k	Carbon Film	$\frac{1}{4}$	5	20-2332
R2	10 k	Carbon Film	$\frac{1}{4}$	5	20-2103
R3	56 k	Carbon Film	$\frac{1}{4}$	5	20-2563
R4	1 M	Carbon Film	$\frac{1}{4}$	5	20-2105
R5	8.2 k	Carbon Film	$\frac{1}{4}$	5	20-2822
R6	10 k	Carbon Film	$\frac{1}{4}$	5	20-2103
R7	56 k	Carbon Film	$\frac{1}{4}$	5	20-2563
R8	100 k	Carbon Film	$\frac{1}{4}$	5	20-2104
R9	47 k	Carbon Film	$\frac{1}{4}$	5	20-2473
R10	8.2 k	Carbon Film	$\frac{1}{4}$	5	20-2822
R11	150 k	Carbon Film	$\frac{1}{4}$	5	20-2154
R12	1M	Carbon Film	$\frac{1}{4}$	5	20-2105
R13	22 k	Carbon Film	$\frac{1}{4}$	5	20-2223
R14	2.2 k	Carbon Film	$\frac{1}{4}$	5	20-2222
R15	1 k	Variable			20-7070
R16	5.9 k	Metal Film	$\frac{1}{4}$	$\frac{1}{4}$	20-4875
R17	2.2 k	Carbon Film	$\frac{1}{4}$	5	20-2222
R18	113 k	Metal Film	$\frac{1}{4}$	$\frac{1}{2}$	20-7518
R19	1 M	Metal Film	$\frac{1}{4}$	1	20-4995
R20	4x22k	DIL Array			20-5527
R21	3.3 k	Carbon Film	$\frac{1}{4}$	5	20-2332
R22	2.2 k	Carbon Film	$\frac{1}{4}$	5	20-2222
R23	100 k	Carbon Film	$\frac{1}{4}$	5	20-2104
R24	100 k	Carbon Film	$\frac{1}{4}$	5	20-2104
R25	2.2 M	Carbon Film	$\frac{1}{4}$	5	20-2225
R26	1.2 k	Carbon Film	$\frac{1}{4}$	5	20-2122
R27	100	Carbon Film	$\frac{1}{4}$	5	20-2101
R28	3.9 k	Carbon Film	$\frac{1}{4}$	5	20-2392
R29	1.5 k	Carbon Film	$\frac{1}{4}$	5	20-2152
R30	8x3.3 k	DIL Array			20-5525

- (b) Receiving the go to local (GTL) command when in the LADS.
- (c) Receiving the REN message false (high). This is independent of the addressed state of the 9303.

4.22.2.2 No change to any of the 9303 control settings occurs on changeover from remote the local control.

4.22.3 LOCAL LOCKOUT (LLO)

4.22.3.1 Operation of the front panel LOCAL key during the transfer of data to the 9303 could result in the instrument being switched from remote to local control with the control settings in an unknown state. To prevent this the LOCAL key can be disabled by setting local lockout.

4.22.3.2 Local lockout may be set at any time when the REN message is true (low). The recognition of the LLO message is not dependent on the addressed state of the instrument. Apart from the disablement of the LOCAL key it causes no changes to the operation of the 9303. The only method of cancelling LLO is to sent the REN message false (high). This affects all instruments on the bus, putting them to the local control state (LOCS).

4.23 **COMMAND CODES FOR ADDRESSED MODE OPERATION**

4.23.1 Once the 9303 has been addressed the instrument functions can be set by means of device dependent commands, consisting of pairs of alpha and numeric characters, as listed in Tables 4.4 to 4.17. If more than one command is to be sent no delimiter is required. The end of message may be signalled by sending any of the terminating groups shown in Table 4.3. The changes in 9303 operation are implemented at the end of the message.

TABLE 4.3

Permitted Terminating Groups

1	2	3	4	5
CR	LF	CR,LF	CR,LF	LF
EOI true			EOI true	EOI true

Cct. Ref.	Value	Description	Rat	Tol %	Racal Dana Part Number
LP11		LED, red (5082.4684)			26-5013
LP12		LED, red (5082.4684)			26-5013
LP13		LED, red (5082.4684)			26-5013
LP14		Not Used			
LP15		LED, red (5082.4684)			26-5013
LP16		Not Used			
LP17		LED, red (5082.4684)			26-5013
LP18		LED, red (5082.4684)			26-5013
LP19		LED, red (5082.4684)			26-5013
LP20		LED, red (5082.4684)			26-5013
LP21		LED, red (5082.4684)			26-5013
LP22		LED, red (5082.4684)			26-5013
<u>Miscellaneous</u>					
S1 to S28		Keyboard switch			23-4103
		Pushbutton for S1 to S28			15-0538
PL3		PCB Header, 26-way			22-3395

TABLE 4.4

Primary Measurement Function Commands

Function	Code
Volts	F0
Watts	F1

TABLE 4.5

$\Omega$  Store Commands

Function	Code
Store contents of numerical input buffer in $\Omega$ store	Q1
Load contents of the $\Omega$ store into the output buffer	Q2

Note: After loading the contents of a store into the output buffer the 9303 must be put to the talker active state for the data to be put onto the bus. The instrument will return to the measurement mode once the output buffer is loaded, but failure to read the buffer contents will prevent measurement data being entered.

PARTS LIST

KEYBOARD AND DISPLAY ASSEMBLY 19-1013

Fig 5

Cct. Ref.	Value	Description	Rat	Tol %	Racal Dana Part Number
<u>Resistors</u>					
	<u><math>\Omega</math></u>		<u>W</u>		
R1	1 k	Carbon Film	$\frac{1}{4}$	5	20-2102
R2	13x330	DIL Array			20-5582
R3	13x330	DIL Array			20-5582
<u>Capacitors</u>					
	<u>F</u>		<u>V</u>		
C1	10 n	Ceramic	25	-20 +80	21-1545
C2	47 n	Ceramic	10	-20 +80	21-1548
<u>Integrated Circuits</u>					
IC1		MD4332			22-4760
IC2		MD4332			22-4760
IC3		MD4332			22-4760
IC4		74LS164			22-4595
IC5		74LS164			22-4595
IC6		74LS164			22-4595
<u>Diodes</u>					
LP1		LED, red (5082.4684)			26-5013
LP2		LED, red (5082.4684)			26-5013
LP3		LED, red (5082.4684)			26-5013
LP4		Not Used			
LP5		Not Used			
LP6		LED, red (5082.4684)			26-5013
LP7		Not Used			
LP8		LED, red (5082.4684)			26-5013
LP9		Not Used			
LP10		LED, red (5082.4684)			26-5013



TABLE 4.6  
Compute Function Commands

Function	Code
Select RATIO	G1
Store the contents of the numerical input buffer in the RATIO store. If the numerical input buffer is empty, store the last measured value.	G2
Load the RATIO store contents into the output buffer	G3
Select dB	L1
Store the contents of the numerical input buffer in the dB store. If the numerical input buffer is empty, store the last measured value	L2
Load the dB store contents into the output buffer	L3
Select NULL	N1
Store the contents of the numerical input buffer in the NULL store. If the numerical input buffer is empty store the last measured value	N2
Load the NULL store contents into the output buffer	N3
Select %	P1
Store the contents of the numerical input buffer in the % store. If the numerical input buffer is empty, store the last measured value	P2
Load the % store contents into the output buffer	P3

- Note: (1) Selection of one compute function will automatically cancel any other compute function. Cancellation code C0 allows cancellation of all computed functions.
- (2) The numerical input buffer is cleared, if required, by means of cancellation code C1.
- (3) After loading the contents of a store into the output buffer the 9303 must be put to the talker active state for the data to be put onto the bus. The instrument will return to the measurement mode once the output buffer is loaded, but failure to read the buffer contents will prevent measurement data being entered.

TABLE 4.7

Range Commands

Range	Code
Autorange	RØ
300 µV	R1
1 mV	R2
3 mV	R3
10 mV	R4
30 mV	R5
100 mV	R6
300 mV	R7
1 V	R8
3 V	R9
Manual Range	RM
Load the output buffer with the full scale value of the range in use	RZ

- Note: (1) The use of code RM will take the instrument from the autorange mode to the manual range mode without changing the range in use.
- (2) After loading the contents of a store into the output buffer the 9303 must be put to the talker active state for the data to be put onto the bus. The instrument will return to the measurement mode once the output buffer is loaded, but failure to read the buffer contents will prevent measurement data being entered.

TABLE 4.8

Head Selection Commands

Measuring Head	Code
Front	VØ
Rear	V1

Cct. Ref.	Value	Description	Rat	Tol %	Racal Dana Part Number
--------------	-------	-------------	-----	----------	---------------------------

### Capacitors

	<u>F</u>		<u>V</u>		
C1	47 $\mu$	Electrolytic	16	20	21-0788
C2	10 n	Ceramic	100	20	21-1738
C3	10 n	Ceramic	100	20	21-1738
C4	47 $\mu$	Electrolytic	16	20	21-0788
C5	1 n	Ceramic	100	20	21-1737
C6	10 n	Ceramic	100	20	21-1738
C7	10 n	Ceramic	100	20	21-1738
C8	47 $\mu$	Electrolytic	16	20	21-0788
C9	10 n	Ceramic	100	20	21-1738
C10	10 n	Ceramic	100	20	21-1738
C11	47 $\mu$	Electrolytic	16	20	21-0788
C12	1 n	Ceramic	100	20	21-1737
C13	47 $\mu$	Electrolytic	16	20	21-0788

### Diodes

D1	Silicon (1N4149)	22-1029
D2	Voltage regulator (BZY88C5V1)	22-1808
D3	Voltage regulator (BZY88C5V1)	22-1808
D4	Voltage regulator (BZY88C5V1)	22-1808
D5	Voltage regulator (BZY88C5V1)	22-1808

### Transistors

Q1	VN10KM	22-6144
Q2	BFX48	22-6110
Q3	2N2369	22-6017

### Inductors

	<u>H</u>		
L1	10 $\mu$	Inductor, miniature	23-7155

TABLE 4.9

Calibrator Control Commands

Function	Code
External calibration turned off	W0
External calibration turned on	W1

TABLE 4.10

Control Setting Storage Commands

Function	Code
Store current control settings and stored values in memory locations numbered 01 to 12	A01 to A12

Note: Memory location 00 always contains the values set when the instrument is first switched on, and cannot be overwritten.

TABLE 4.11

Control Setting Recall Commands

Function	Code
Recall and set initial control settings	B00
Recall and set control settings from stores numbered 01 to 12	B01 to B12
Recall control settings in use when instrument was last switched off	B99

Note: (1) The data stored in location 99 is overwritten as each change of instrument settings is made. The facility for recalling the settings in use when the instrument was switched off is only available immediately after switching on.

(2) Either the Device Clear (DCL) or the Selective Device Clear (SDC) command may be used instead of B00.

Cct. Ref.	Value	Description	Rat	Tol %	Racal Dana Part Number
-----------	-------	-------------	-----	-------	------------------------

Diodes

D1					
D2		Hot Carrier, matched			
D3		set of four (5082.2815)			22-1063
D4					
D5		Step Recovery (A4S112)			22-1059

Transistors

Q1		BFR30			22-6143
Q2		BCW32R			22-6142

Inductors

T1		Transformer			17-3221
T2		Transformer			17-3222
L1		30 mm x 0.18 mm (36 SWG) enamelled copper wire wound on D5			25-4512

DRIVER BOARD 19-1012

Resistors

	$\Omega$		<u>W</u>		
R1	47 (nom.)	Carbon Film	$\frac{1}{4}$	5	20-2470
R2	1 k	Metal Oxide	$\frac{1}{2}$	5	20-3102
R3	120	Carbon Film	$\frac{1}{4}$	5	20-2121
R4	1 k	Carbon Film	0.1	5	20-1521
R5	4.7	Carbon Film	$\frac{1}{4}$	5	20-2008
R6	120	Carbon Film	0.1	5	20-1523
R7	390	Carbon Film	0.1	5	20-1530
R8	1.2 k	Carbon Film	0.1	5	20-1544
R9	680	Carbon Film	0.1	5	20-1554
R10	4.7 k	Carbon Film	0.1	5	20-1542
R11	10 k	Variable			20-7074
R12	3.3 k	Carbon Film	0.1	5	20-1537
R13	2.7 k	Carbon Film	0.1	5	20-1547
R14	2.7 k	Carbon Film	0.1	5	20-1547
R15	1 k	Carbon Film	0.1	5	20-1521
R16	1 k	Carbon Film	0.1	5	20-1521
R17	100	Carbon Film	0.1	5	20-1514
R18	2 k	Variable			20-7073
R19	100	Carbon Film	0.1	5	20-1514
R20	100	Carbon Film	0.1	5	20-1514

TABLE 4.12  
Calibrate Commands

Function	Code
Disable USER ECAL factor	K0
Enable USER ECAL factor	K1
Measure and store USER ECAL factor	K2
Load contents of USER ECAL store into the output buffer	K3
Load contents of noise cancellation store into the output buffer	K4
Timed ACAL sequences enabled	K5
Trigger an immediate ACAL	K6
ACAL inhibited	K7

Note: Codes K0 to K4 relate to the measuring head selected when the command is executed.

TABLE 4.13  
Calibration Factor Commands

Function	Code
Disable calibration factor	U0
Enable calibration factor	U1
Store contents of numerical input buffer in calibration factor store	U2
Load contents of calibration factor store into the output buffer	U3

Note: (1) Codes U0 to U3 relate to the measuring head selected when the command is executed.

- (2) After loading the contents of a store into the output buffer the 9303 must be put to the talker active state for the data to be put onto the bus. The instrument will return to the measurement mode once the output buffer is loaded, but failure to read the buffer contents will prevent measurement data being entered.

PARTS LIST  
MEASURING HEAD ASSEMBLY

Fig 3

Cct. Ref.	Value	Description	Rat	Tol %	Racal Dana Part Number
<u>SENSOR BODY ASSEMBLY (1 m cable) 11-1479</u>					
<u>SENSOR BODY ASSEMBLY (2 m cable) 11-1539</u>					
SK1		Socket, RF, type N			23-3323
PL1		Plug, RF, type N			23-3324
		50 $\Omega$ load			23-3329
<u>SAMPLER BOARD 19-1011</u>					
<u>Resistors</u>					
	<u><math>\Omega</math></u>		<u>W</u>		
R1	18	Chip	0.125	5	20-5763
R2	100 k	Carbon Film	0.1	5	20-1551
R3	2.7 k	Chip	0.125	5	20-5766
R4	2.7 k	Chip	0.125	5	20-5766
R5	1 M	Carbon Film	0.1	5	20-1561
R6	22 k	Carbon Film	0.1	5	20-1563
R7	8.2 k	Chip	0.125	5	20-5767
R8	8.2 k	Chip	0.125	5	20-5767
R9	8.2 k	Chip	0.125	5	20-5767
R10	100	Chip	0.125	5	20-5764
R11	470	Chip	0.125	5	20-5765
<u>Capacitors</u>					
	<u>F</u>		<u>V</u>		
C1	1 n	Chip	100	10	21-1718
C2	1 n	Chip	100	10	21-1718
C3	1 n	Chip	100	10	21-1718
C4	100 p	Chip	100	20	21-1711
C5	10 n	Ceramic	100	20	21-1738
C6	10 n	Chip	100	10	21-1719
C7	10 n	Chip	100	10	21-1719
C8	1 n	Chip	100	10	21-1718
C9	1 n	Chip	100	10	21-1718
C10	5.6 p	Chip	100	0.5 p	21-1713
C11	1.5 p	Chip	50	0.25 p	21-1744

TABLE 4.14  
Interrupt Commands

Function	Code
No service requests generated	I0
Service request generated when measured value is available	I1
Service request generated when error is detected	I2
Service request generated when measured value is available or when error is detected.	I3
Load error code number into output buffer	I4

- Note: (1) After loading the contents of a store into the output buffer the 9303 must be put to the talker active state for the data to be put onto the bus. The instrument will return to the measurement mode once the output buffer is loaded, but failure to read the buffer contents will prevent measurement data being entered.
- (2) The loading of the error code into the output buffer does not cancel the error code. Error codes other than 01 are cancelled using the cancellation code C2.





TABLE 4.15

Measurement Averaging Mode and Timing Selection Commands

Function	Code
Select fixed averaging mode	S0
Select continuous averaging mode	S1
Store contents of numerical input buffer in the AVERAGE store	S2
Load contents of the AVERAGE store into the output buffer	S3
Store contents of numerical input buffer in the TRIGGER DELAY store	S4
Load contents of the TRIGGER DELAY store into the output buffer	S5

Note: After loading the contents of a store into the output buffer the 9303 must be put to the talker active state for the data to be put onto the bus. The instrument will return to the measurement mode once the output buffer is loaded, but failure to read the buffer contents will prevent measurement data being entered.

PARTS LIST

FRONT AND REAR PANEL ASSEMBLIES

Fig. 1 and Fig. 7

Cct. Ref.	Value	Description	Rat	Tol %	Racal Dana Part Number
-----------	-------	-------------	-----	-------	------------------------

FRONT PANEL ASSEMBLY 11-1487

Liquid crystal display or 17-1025  
17-1022

Note: The display fitted must be compatible with the ROM set fitted in positions IC16 to IC19 on assembly 19-1014.

Display	ROM set
17-1025	22-8540 to 22-8537 or 22-8570 to 22-8567
17-1022	22-8515 to 22-8512

	Elastomeric connector	23-5600
SK2	Socket, 7-way	23-3301
SK1	Cableform assembly	10-2698

REAR PANEL ASSEMBLY 11-1488

T1	Transformer, power	17-4097
IC41	Voltage regulator, +5 V (7805)	22-4222
FS2	Fuse link (99 V to 132 V) 500 mA anti-surge Fuse link (198 V to 264 V) 250 mA anti-surge	23-0052 23-0056
SK17	Socket, RF, type N	16-0597
SK18	Socket, 7-way Cableform assembly	23-3301 10-2699
	AC power plug, filter and fuse holder	23-3294

TABLE 4.16  
Trigger Commands

Function	Code
Perform continuous measurement cycles, updating the output buffer at the end of each cycle	T0
Leave the continuous measurement mode and enter the triggered measurement mode	T1
If in the triggered measurement mode, perform one averaged measurement and update the output buffer.	T2
If in the triggered measurement mode, perform one averaged measurement after a delay, equal to the value in the trigger delay store, and update the output buffer.	T3

- Note: (1) After a change of range a three second delay, additional to that held in the trigger delay store, is automatically inserted after the trigger command.
- (2) The Group Execute Trigger (GET) command may be used instead of code T2 using the following procedure:
- a) Send command T1.
  - b) Send command T2. The 9303 will perform one measurement cycle.
  - c) Send the GET command each time a further measurement cycle is required. Note that, when using the GET command, the 9303 must be put to the talker active state after each measurement cycle.
- (3) The use of the GET command after code T0 has been used will terminate the current measurement cycle. A new cycle will begin immediately.
- (4) The instrument will revert to continuous measurement if the continuous averaging mode is selected (see Table 4.15). If the continuous averaging mode is cancelled the instrument will return to the last trigger mode enabled.



TABLE 4.17

Cancellation Commands

Function	Code
Cancel compute functions	C0
Clear numerical input buffer	C1
Clear error code	C2

Note: Code C2 will not cancel error code 01.

4.24 ENTRY OF NUMERICAL VALUES

4.24.1 The format for numbers to be entered in the numerical input buffer for subsequent loading into the internal stores is given in Table 4.18.

TABLE 4.18

Numerical Input Format

Byte	Interpretation	Permitted ASCII Characters
1	Sign of mantissa	Space or +
2	Most significant digit	Up to four digits, with a decimal point if required, may be entered. Unused bytes need not be filled. Excess spaces are ignored.
3	Digit/decimal point	
4	Digit/decimal point	
5	Digit/decimal point	
6	Least significant digit	
7	Exponent indicator	E or e
8	Sign of exponent	Space, + or -
9	Digit	0 to 9

- Note: (1) An unsigned mantissa or exponent is assumed positive. Bytes 1 and/or 8 may be omitted when the sign is positive.
- (2) The string may be terminated with CR, LF or by the first byte of the succeeding command.
- (3) If the exponent group is not required bytes 7 to 9 may be omitted.
- (4) The exponent group replaces the units keys used when entering values in local control. The units assumed by the numbers held in store are given in Table 4.19.

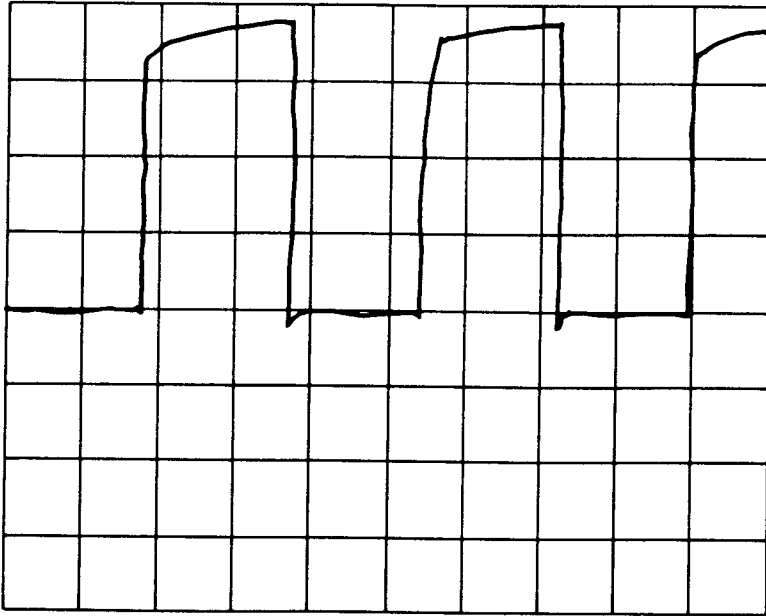

Monitor Point IC 16/8  
Vertical scale 1 V/division  
Horizontal scale 0.5  $\mu$ s/division  
DC coupled  
Internal trigger

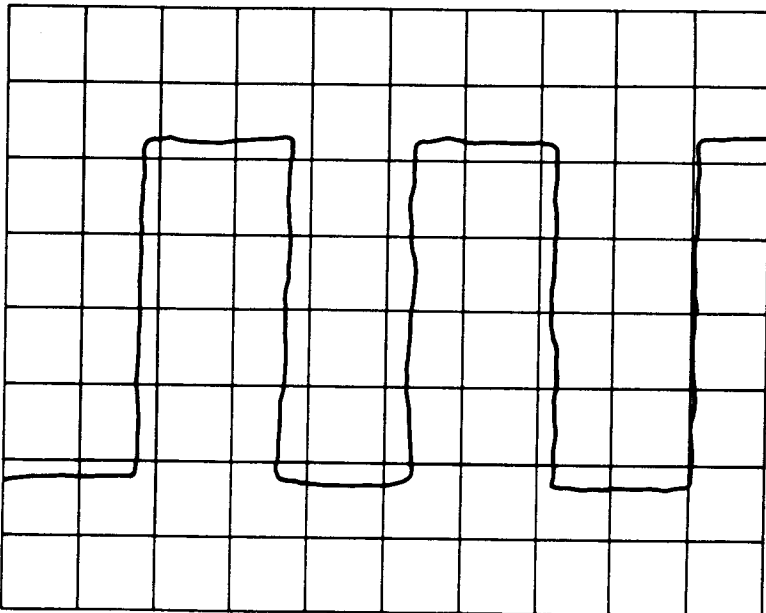

Monitor Point SK 8  
Vertical scale 200 mV/division  
Horizontal scale 0.5  $\mu$ s/division  
Mean DC level 0 V  
DC coupled  
Internal trigger

TABLE 4.19

Stored Value Units

Store	Units	
	VOLTS Mode	WATTS Mode
Ohms	$\Omega$	$\Omega$
Ratio	Volts	Watts
%	Volts	Watts
Null	Volts	Watts
dB	Volts	Watts
Average	Seconds	Seconds
Time Out	Seconds	Seconds
Calibration factor	Number	Number

4.25 **OUTPUT MESSAGE FORMAT**

4.25.1 The same output message format is used for the transmission of measured values, error code numbers or the values held in the instrument's internal stores. The message consists of a string of 12 ASCII characters for each value transmitted. These are to be interpreted as shown in Table 4.20. No parity check is included. Each byte is accompanied by the full handshake procedure on the NRFD, DAV and NDAC control lines.

TABLE 4.20

Interface Output Message Format

Byte No	Interpretation	Permitted ASCII Characters
1	Sign of mantissa	+ or -
2	Most significant digit	0 to 9
3	Decimal point	.
4	Digit	0 to 9
5	Digit	0 to 9
6	Least significant digit	0 to 9
7	Exponent indicator	E
8	Sign of exponent	+ or -
9	More significant digit	0 to 9
10	Less significant digit	0 to 9
11	Carriage return	CR
12	Line Feed	LF



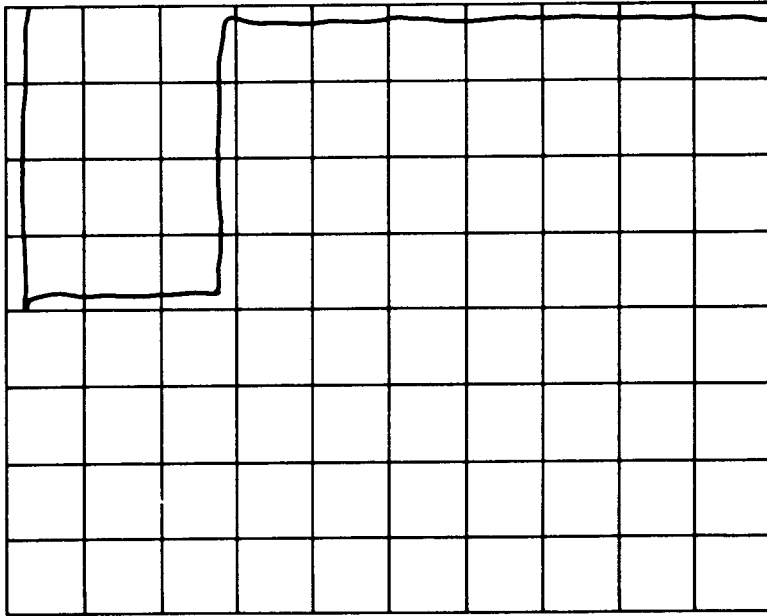

Monitor Point TP 10  
Vertical scale 1 V/division  
Horizontal scale 0.5  $\mu$ s/division  
DC coupled  
Internal trigger

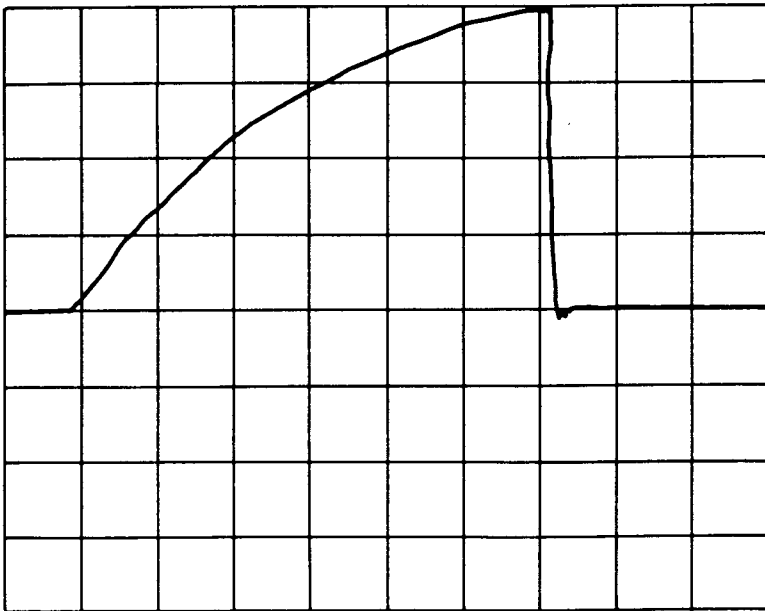

Monitor Point IC 16/3  
Vertical scale 1 V/division  
Horizontal scale 0.2  $\mu$ s/division  
DC coupled  
Internal trigger

## 4.26 STATUS BYTE FORMAT

4.26.1 The data line usage for the status byte, generated in response to a serial poll, is given in Table 4.21.

TABLE 4.21

Status Byte

DIO Line	Function
1	Not used
2	Not used
3	Not used
4	Not used
5	'1' indicates that the instrument is busy
6	'1' indicates that an error has been detected
7	'1' indicates that service was requested
8	Not used

NOTE: The status byte does not provide information about the nature of any error which has been detected. The addressed command I4 can be used to have the error number loaded into the output buffer. This will then be transmitted via the bus when the instrument is addressed to talk.

## 4.27 SERVICE REQUEST (SRQ) OUTPUT

4.27.1 The instrument can be instructed via the bus to generate an SRQ output as follows:

- (a) SRQ generation inhibited
- (b) SRQ sent true when data are available
- (c) SRQ sent true when an error is detected
- (d) SRQ sent true when data are available or when an error is detected

The codes used are given in Table 4.14. Option (d) is adopted automatically on switching on.

4.27.2 When the 9303 is being used in the triggered mode a delay, equal to the value set in the AVERAGE store, will occur between the generation of the SRQ output and the appearance of the SRQ annunciator on the front panel.

## 4.28 LOGIC LEVELS

4.28.1 The control, handshake and data lines operate at standard +5 V TTL levels. Negative logic is used, i.e. logic '1' is represented by a level  $\leq 0.8$  V and logic '0' by a level  $> 2$  V.

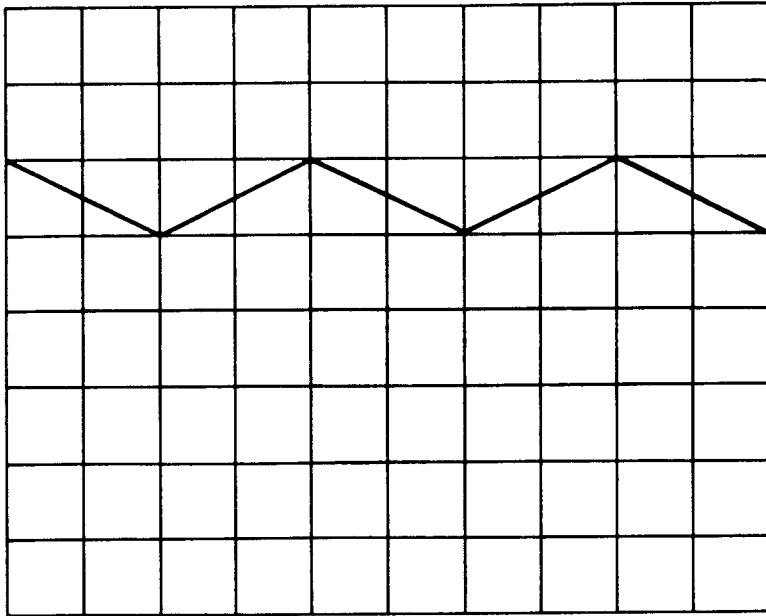

Monitor Point TP 9  
Vertical scale 5 V/division  
Horizontal scale 20 ms/division  
DC coupled  
Internal trigger

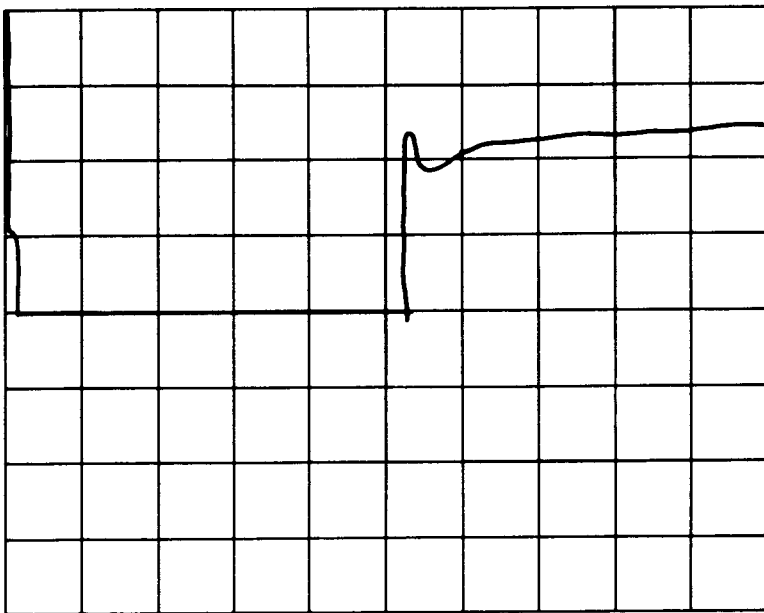

Monitor Point TP 11  
Vertical scale 2 V/division  
Horizontal scale 1  $\mu$ s/division  
DC coupled  
Internal trigger

**5.1 INTRODUCTION**

5.1.1 This section is written in two parts. Paragraph 5.2 covers the operating principles of the 9303 in general terms, with reference to the block diagram, Fig. 5.1. Paragraph 5.3 describes the operation of the circuits in greater detail, with reference to the circuit diagrams given in Section 7. It is essential that the principles of operation are understood before the detailed circuit description is read.

5.1.2 In the circuit descriptions the integrated circuits are referred to by the circuit reference given on the appropriate circuit diagram. Note that a separate series of numbers, starting at IC1, is allocated to each assembly. Where an integrated circuit package contains more than one circuit, suffix letters are used to distinguish between them. Where it is necessary to identify a particular pin of an integrated circuit, the circuit reference, with suffix letter if appropriate, is followed by an oblique stroke and the required pin number.

**5.2 PRINCIPLES OF OPERATION****5.2.1 FUNCTIONAL SYSTEMS**

5.2.1.1 The instrument contains six functional systems. These are:

- (a) A pseudo-random signal sampling system
- (b) An analogue signal processing system
- (c) A microprocessor system, which operates both as a digital signal processor and a control system
- (d) A keyboard/display system
- (e) A calibrator system
- (f) An interface to the IEEE 488 GPIB

**5.2.2 THE SAMPLING SYSTEM**

5.2.2.1 The sampling system uses a diode sampling bridge to measure the voltage across the  $50\Omega$   $\mu$ -stripline conductor in the measuring head. The sampling period is approximately 300 ps, but the waveform of the sample taken is shaped to give a pulse which reaches its maximum value after approximately 1.5  $\mu$ s. This pulse may be positive or negative going, according to the polarity of the measured signal at the instant of sampling.

5.2.2.2 To prevent the sampling frequency ever being an exact sub-multiple of the measured signal frequency, the sampling process is made pseudo-random by varying the sampling frequency over the range from 35 kHz to 70 kHz at a rate of 10 Hz. A 100 Hz signal, from a clock on assembly 19-1014, is divided by 10 and applied to an integrator in the timer and sweep generator on assembly 19-1015. This provides a 10 Hz triangular waveform, which is applied to the voltage-controlled oscillator (VCO) on assembly 19-1016. The variable frequency pulse waveform from this oscillator drives the sampling pulse generators, which are mounted within the measuring heads.

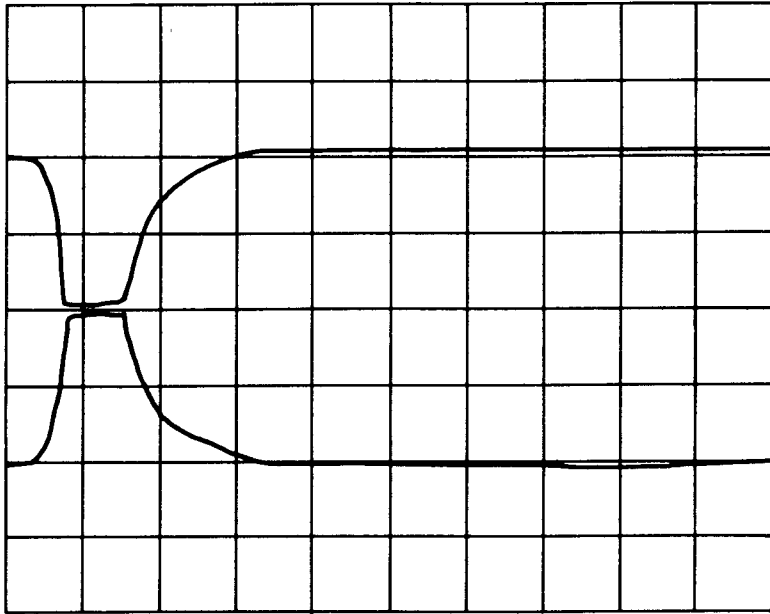

Monitor Point TP 2  
Vertical scale 200 mV/division  
Horizontal scale 1  $\mu$ s/division  
Mean DC level 0 V

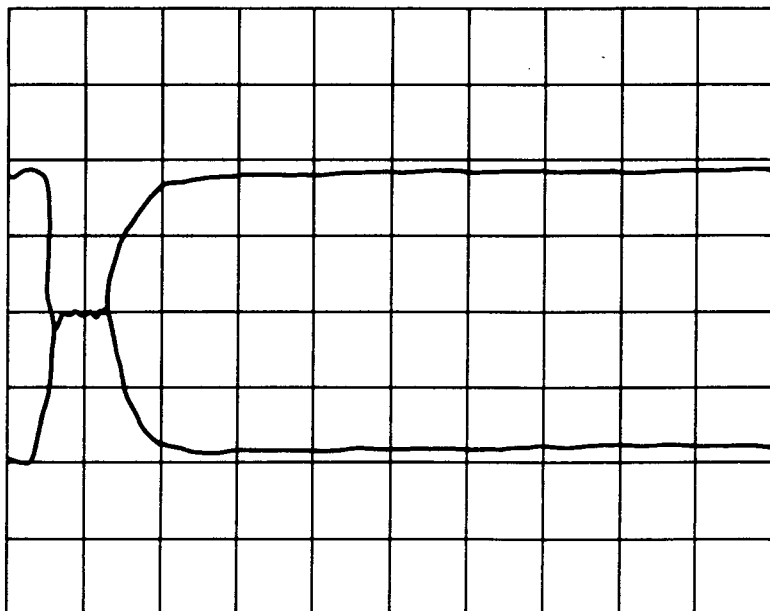

Monitor Point TP 1  
Vertical scale 200 mV/division  
Horizontal scale 1  $\mu$ s/division  
Mean DC level 0 V

5.2.2.3 If zero signal is to be obtained from the sampling head when no measured signal is applied, the sampling bridge must be balanced symmetrically about 0 V. Once the bias voltages have been set to achieve this, balance is maintained automatically by the bias level control circuit on assembly 19-1016.

### 5.2.3 THE ANALOGUE PROCESSING SYSTEM

5.2.3.1 The analogue processing system measures the true r.m.s. value of the train of bipolar pulses fed to it from the sampling system. The measuring head to be used is selected by means of a multiplexer on assembly 19-1016. The pulses from the measuring head are applied to the high frequency sample and hold circuit during a gate period of approximately 1.5 ms. The gating signal is derived from the sampling pulse drive VCO, and its start is coincident with the sampling pulse. During the gate period the pulse from the measuring head reaches a peak value, and this value is held until the next gate period occurs.

5.2.3.2 The sample and hold circuit output therefore has a bipolar pulsed waveform. The amplitude of each pulse is proportional to the amplitude of the related sample taken from the measured signal, while the pulse frequency is the same as the sampling frequency. The output is clamped during the gate period to ensure that each voltage transition starts from the same level. The r.m.s. value of the output waveform is proportional to the r.m.s. value of the measured signal.

5.2.3.3 To permit measurements to be made over a wide range of input levels, while maintaining a restricted range of output levels from the sample and hold circuit, a switched gain amplifier is included in the analogue signal path on assembly 19-1016. The gain variation is obtained by means of electronically switched attenuators of 10dB, 20dB, 30dB and 30dB, which provide attenuations from 0dB to 90dB in 10dB steps. The insertion of the attenuators is controlled by the microprocessor system.

5.2.3.4 The alternating signal from the sample and hold circuit is fed to a true r.m.s. measuring circuit on assembly 19-1015. The measuring circuit is in the form of a feedback loop containing a differential multiplier, an integrator and an amplifier, and features an auto-zeroing system which cancels out the effects of noise and the multiplier input offsets.

5.2.3.5 The output of the analogue processing system is fed to the analogue-to-digital converter on assembly 19-1014 via a sample and hold circuit, which maintains a steady input to the converter during the auto-zeroing period of the r.m.s. detector.

### 5.2.4 THE MICROPROCESSOR SYSTEM

5.2.4.1 The microprocessor system is contained on assembly 19-1014. The system performs two separate functions:

- (a) It converts the output of the voltage measuring circuits to digital form. The result is operated upon arithmetically to provide the measured value to be displayed.
- (b) It provides signals to control the operation of the instrument in accordance with instructions entered by the operator.

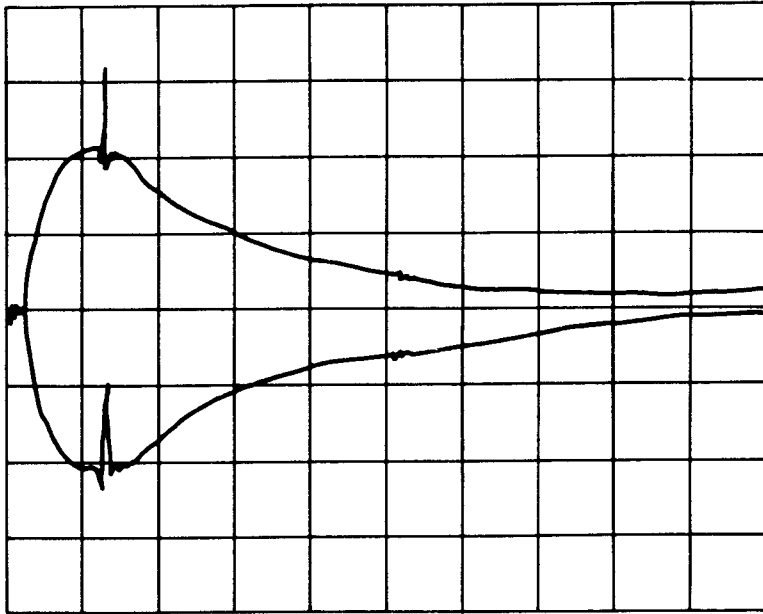

Monitor Point TP 4  
 Vertical scale 50 mV/division  
 Horizontal scale 1  $\mu$ s/division  
 Mean DC level 10 V

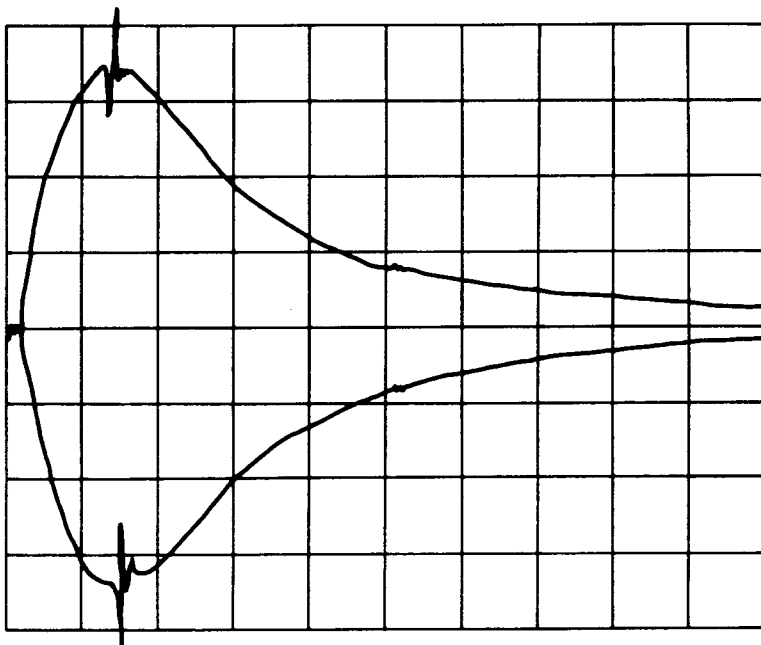

Monitor Point TP 3  
 Vertical scale 100 mV/division  
 Horizontal scale 1  $\mu$ s/division  
 Mean DC level 10 V

5.2.4.2 The microprocessor is interrupt controlled, IRQs being generated every 100ms by the measured signal peripheral interface adaptor (PIA), at every operation of a key in the input/output system and for every data byte received by the GPIB interface.

#### 5.2.4.3 Digital Signal Processing

5.2.4.3.1 The output of the r.m.s. detector is converted to digital form in the analogue-to-digital converter. In response to an IRQ from the measured signal PIA the output of the converter is scaled, according to the values held in the ACAL and FACTORY ECAL stores (and the USER ECAL and CAL FACTOR stores if these are enabled) and stored. A number of successive values, determined by the value held in the AVERAGE store, are then averaged. After noise cancellation the averaged value is processed, in accordance with the primary and computed measurement functions in use, to provide the value which is to be displayed. This value is used to set up a 96-bit serial data string, which is fed to the display on assembly 19-1013. The system also converts the value to be displayed into the nine data bytes of the GPIB output word. The exponent indicator byte and the CR and LF terminating bytes are incorporated to complete the output word, which is fed to assembly 19-1017 after the display has been updated.

#### 5.2.4.4 Instrument Control

5.2.4.4.1 The majority of the instructions governing the operation of the instrument are internal to the microprocessor system, and govern such matters as the manner in which measurement data are processed, the selection of data to be displayed, the storage of data displayed or entered via the keyboard, range setting, error detection, etc. External control lines are limited to:

- (a) Selection of the input to the switched gain amplifier
- (b) Gain of the switched gain amplifier (attenuator switching)
- (c) Calibrator system switching

In addition, the microprocessor system provides a 100 Hz output which provides the drive for the timer and sweep generator on assembly 19-1015.

#### 5.2.5 THE KEYBOARD/DISPLAY SYSTEM

5.2.5.1 The keyboard/display system incorporates a custom built liquid crystal display (LCD). At display update the fresh data to be displayed, which may be the output of the digital signal processor, the contents of a store or an error code, is fed to assembly 19-1013 in the form of a 96-bit serial data string. This is fed into three 32-bit shift registers to convert it from serial to parallel form, the shift register outputs being latched until the next display update occurs. Each element of the LCD is controlled from a separate shift register output. The time taken to update the display is extremely short, and display blanking during updating is unnecessary. The 30Hz alternating supply for the LCD is obtained from an oscillator on assembly 19-1014.



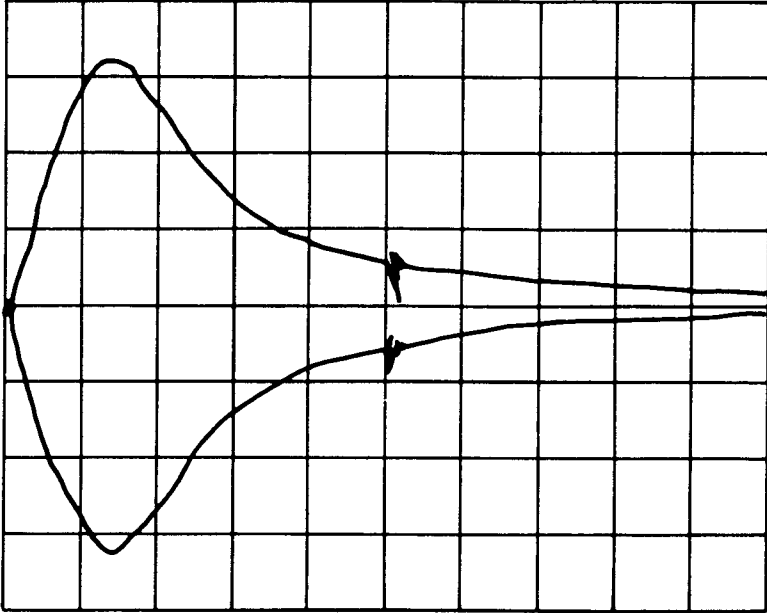

Monitor Point TP 6  
 Vertical scale 10 mV/division  
 Horizontal scale 1  $\mu$ s/division  
 Mean DC level 9 V

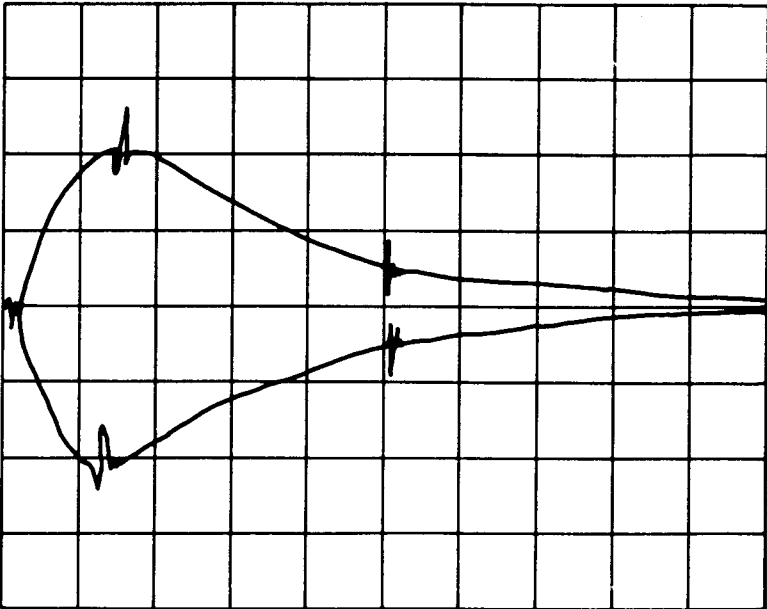

Monitor Point TP 5  
 Vertical scale 5 mV/division  
 Horizontal scale 1  $\mu$ s/division  
 Mean DC level 10 V

5.2.5.2 The input section of the system is formed by a 7 x 4-line keyboard. This may be used to give instructions to the control system or to enter values into the stores used during the digital signal processing. Each key operation generates an IRQ, and is serviced individually by the microprocessor. The first of a series of numeric key operations puts the display to the numbers mode. In this mode the instrument continues to make measurements, but the display continues to show the numbers entered until the instrument is returned to the measurement mode.

## 5.2.6 THE CALIBRATOR SYSTEM

5.2.6.1 The calibrator system generates two independent outputs. One of these, driven by the sampling pulse drive VCO, provides pulses shaped to simulate the output of a measuring head. These are used to calibrate the measuring circuits in the analogue processing system during the automatic internal calibration (ACAL) sequence. The second output is a fixed frequency square wave having a true r.m.s. value of 223.6 mV in 50 $\Omega$ . This output is available at the front and rear panel CALIBRATOR sockets, and may be used for the external calibration of the measuring heads (FACTORY ECAL) and for the measurement of the USER ECAL factors for use with measuring head attachments.

5.2.6.2 Both calibrator outputs are controlled automatically by the microprocessor during calibration sequences. In addition the use of the special functions permits operator control of the external calibrator output.

## 5.2.7 THE GPIB INTERFACE

5.2.7.1 The following functions are carried out by the GPIB interface without involvement of the microprocessor system.

- (a) Distinguishing between universal and addressed commands occurring on the bus.
- (b) Talk and listen address recognition.
- (c) Generation of the signals required by the handshake protocol.

5.2.7.2 The interface passes device dependent data and certain universal bus commands between the bus and the microprocessor. An interrupt is generated for each of the following situations:

- (a) A device dependent data byte is held in the data-in register for the microprocessor to read.
- (b) The last device dependent data byte loaded into the data-out register has been read by the bus.
- (c) DCL or SDC received.
- (d) GET received.
- (e) SPE or SPD received.
- (f) Instruction to change remote/local status (RLC) received. This may be the REN message received false or the GTL command received when in the remote control mode, or REN and the listen address received when in the local control mode.

TEST WAVEFORMS

Assembly 19-1016

TEST CONDITIONS

Measuring head connected to the appropriate CALIBRATOR socket.

Special function 30.1 active.

Oscilloscope externally triggered from TP11, except where stated.

AC coupling, except where stated.

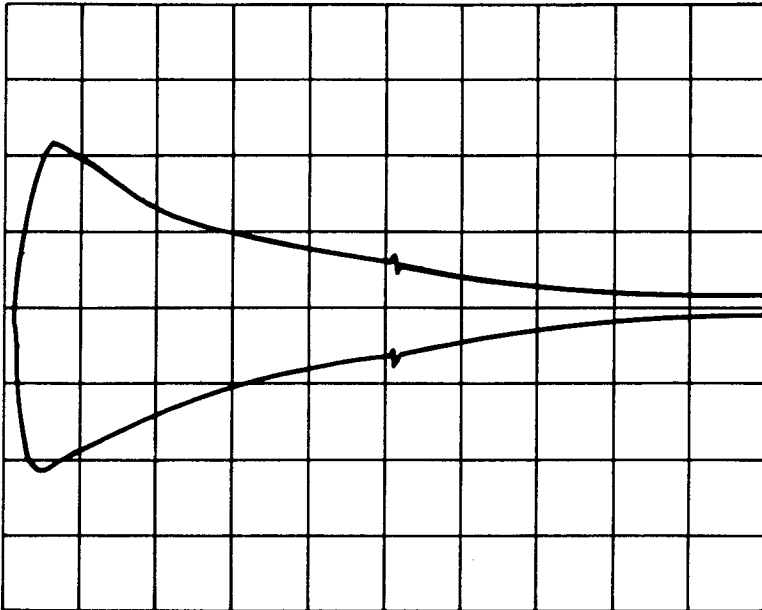

Monitor point R66  
Vertical scale 50 mV/division  
Horizontal scale 1  $\mu$ s/division  
Mean DC level -0.6 V

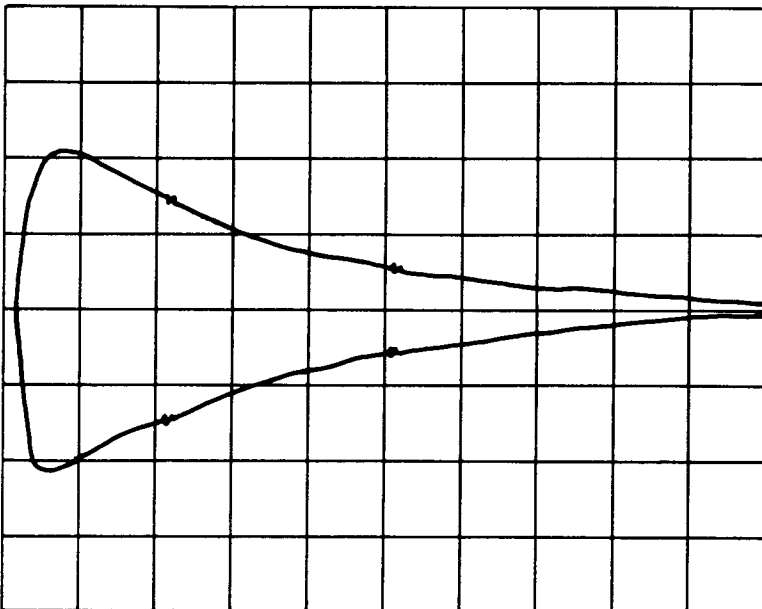

Monitor point TP7  
Vertical scale 50 mV/division  
Horizontal scale 1  $\mu$ s/division  
Mean DC level 2.5 V

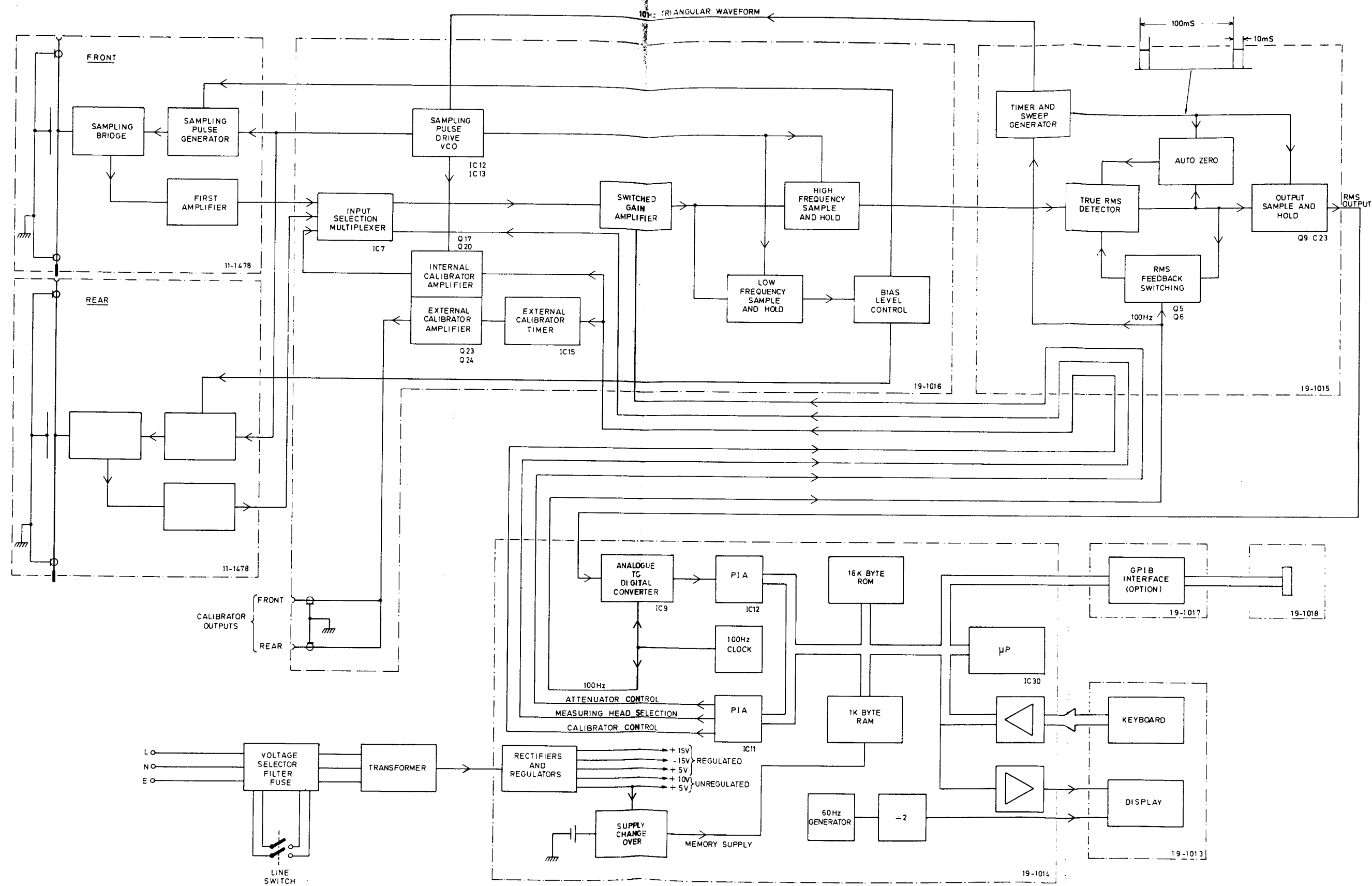

**RACAL**  
TH3174

9303

Fig. 5.1 Block Diagram

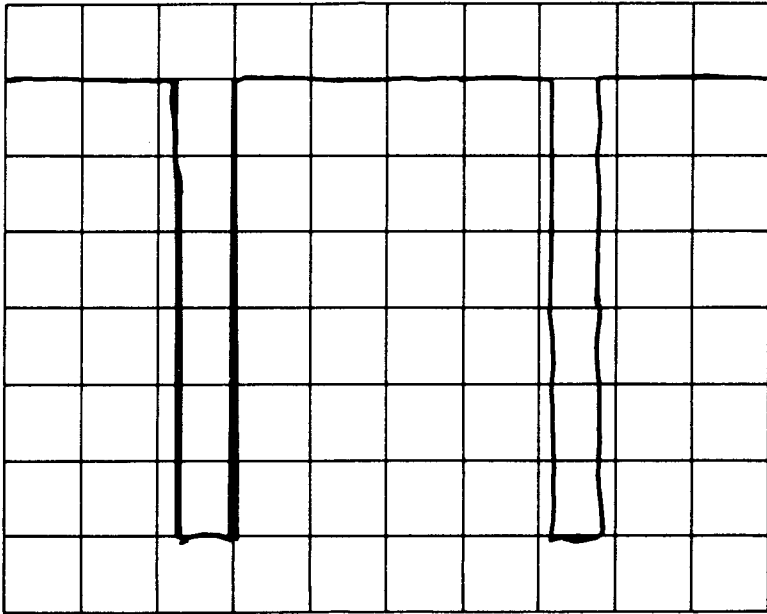

Monitor Point TP 4  
Vertical scale 5 V/division  
Horizontal scale 20 ms/division

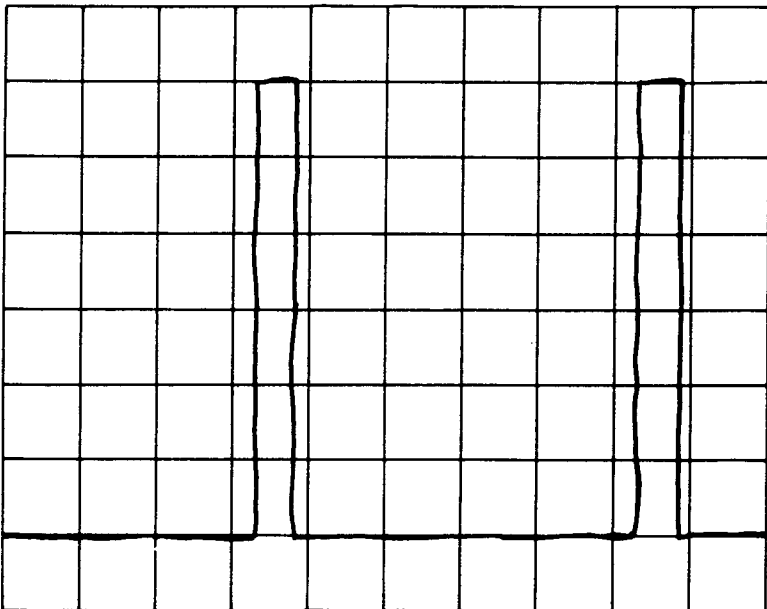

Monitor Point TP 5  
Vertical scale 5 V/division  
Horizontal scale 20 ms/division



TEST WAVEFORMS

Assembly 19-1015

TEST CONDITIONS

Measuring head connected to the appropriate CALIBRATOR socket.  
Special function 30.1 active.  
Oscilloscope internally triggered.  
DC Coupling.

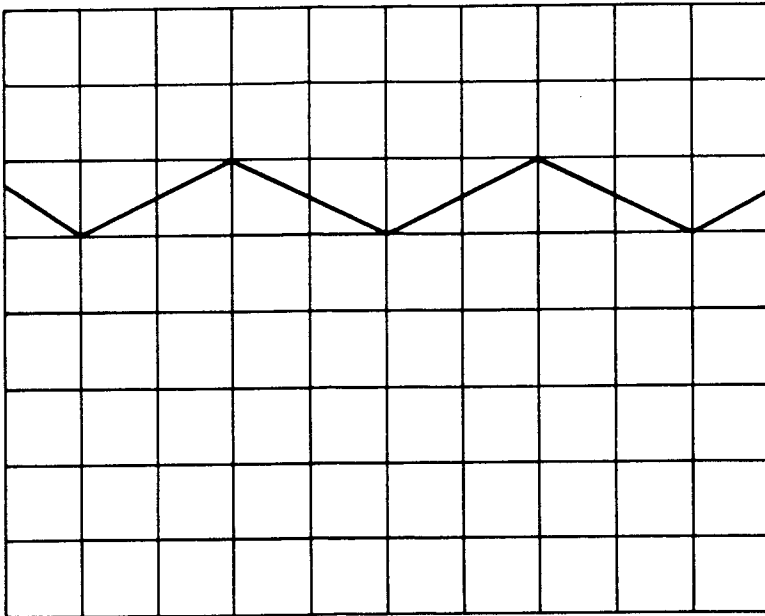

Monitor Point TP 3  
Vertical scale 5 V/division  
Horizontal scale 20 ms/division

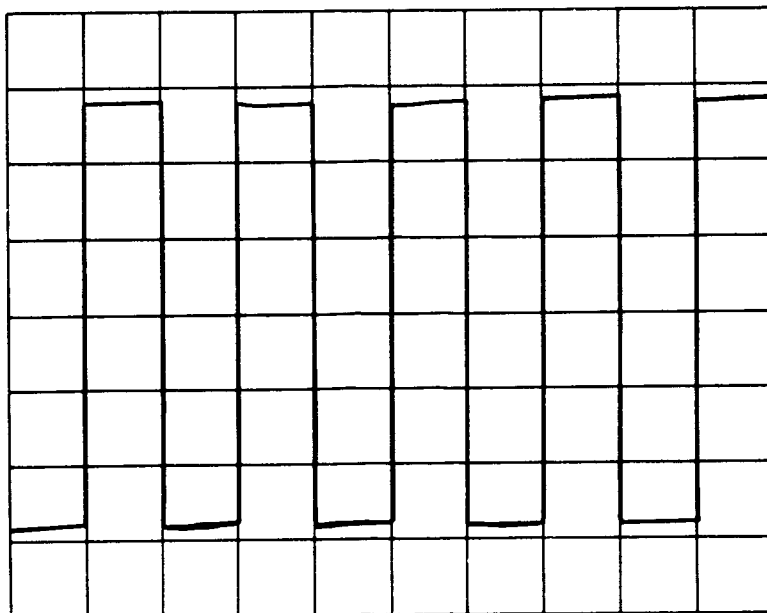

Monitor Point TP 2  
Vertical scale 5 V/division  
Horizontal scale 5 ms/division

## 5.3 TECHNICAL DESCRIPTION

### 5.3.1 THE SAMPLING SYSTEM

5.3.1.1 The sampling system involves circuits mounted on five printed circuit boards. Three of these, assemblies 19-1014, 19-1015 and 19-1016 are mounted in the instrument. The other two, assemblies 19-1011 and 19-1012, are mounted in the measuring head. The circuit diagrams for these assemblies are given in Fig. 3, Fig. 7, Fig. 9 and Fig. 11 in Section 7 of this manual.

#### 5.3.1.2 10 Hz Triangular Waveform Generation

5.3.1.2.1 The timing of the 10 Hz triangular waveform is controlled by the 100 Hz clock, IC3, on assembly 19-1014. The voltage at IC3c/9 is switched between a high and a low level by feedback via R5. The voltage at IC3c/8 ramps towards that at IC3c/9 as C15 charges or discharges via R8. Switching of the voltage level at IC3c/14 occurs each time the voltage at IC3c/8 passes through the level at IC3c/9.

5.3.1.2.2 The clock output passes off assembly 19-1014 at PL15 pin 19 and enters assembly 19-1015 at PL12 pin 19. Here the waveform passes via the driver, IC1d, and clocks the divide-by-ten circuit, IC2. The 10 Hz, unity mark/space ratio waveform occurring at IC2/12 is applied to the integrator, IC1a. The integrator output, which can be monitored at TP3, has a triangular waveform and a frequency of 10 Hz. The waveform leaves assembly 19-1015 at PL11 pin 16.

#### 5.3.1.3 Voltage Controlled Oscillator

5.3.1.3.1 The triangular waveform generated on assembly 19-1015 enters assembly 19-1016 at PL4 pin 16, and is applied to the voltage controlled oscillator formed by IC12 and Q25. As the collector current of Q25 charges C46 the voltage at IC12/2 goes more positive, IC12 being triggered when this voltage equals the internally set trigger level. When this occurs C46 is discharged through IC12/7 and an internal current sink, so that the voltage at IC12/2 and 6 falls. When IC12/6 falls below an internally set threshold level IC12 is reset, disabling the current sink. C46 commences to charge, and the cycle is repeated.

5.3.1.3.2 The frequency of the oscillator depends upon the time taken for the voltage at IC12/2 to change from the threshold level to the trigger level, and therefore upon the collector current of Q25. This is controlled by the 10 Hz triangular waveform, so that the output of IC12 is frequency modulated at 10 Hz. The limits of the frequency sweep are approximately 35 kHz and 70 kHz.

5.3.1.3.3 The variable frequency output from IC12/3 clocks a monostable circuit, IC13b, which provides pulses of controlled length at IC13b/12 and 5. The nominal pulse duration is 1.5  $\mu$ s, and is set by adjustment of R99.





#### 5.3.1.4 Sampling Pulse Generation

- 5.3.1.4.1 The positive going pulses from IC13b/5 pass to the front or rear INPUT socket, via the gate formed by IC14 a, b, c and d, and so to the measuring head in use. The gate directs the pulses according to the logic levels present at IC14c/5 and IC14a/1. These levels are set on the measuring head selection lines by the microprocessor system. A logic '0' on the control line disables the related drive pulse output.
- 5.3.1.4.2 The measuring head contains assemblies 19-1011 and 19-1012. In the quiescent state Q3, Q2 and Q1 on assembly 19-1012 do not conduct. Current flows from the +15 V rail through L1, R2 and R1 on assembly 19-1012 and then through the step-recovery diode D5 and L1 on assembly 19-1011. Charge storage occurs in the diode.
- 5.3.1.4.3 When a positive going pulse occurs at pin 1 of board 19-1012, Q3, Q2 and Q1 all conduct. The voltage at Q1 drain falls, so that the step-recovery diode is reverse biased, and a high reverse current flows in D5, L1 and R1 until the charge stored in D5 is reduced to zero. At this point the diode cuts off rapidly, and the energy stored in L1 gives a pulse in the circuit consisting of L1, C3, T2, T1, the sampling bridge, T1, T2 and C2. The amplitude of this pulse is determined in part by the value of the reverse current which occurs when D5 is reverse biased, since this determines the energy stored in L1. The value of this reverse current depends on the value of R1.
- 5.3.1.4.4 Transformers T1 and T2 ensure that the current pulse gives symmetrical, antiphase voltage pulses, positive at the D2/D4 junction, across the sampling bridge. The voltage across the bridge is sufficient to overcome the reverse bias applied via pins 3 and 4 of assembly 19-1011, so that the bridge is forward biased for the duration of the sampling pulse.

#### 5.3.1.5 Sampling Bridge Operation

- 5.3.1.5.1 The  $\mu$ -stripline carrying the signal to be measured is connected to the sampling bridge by C1 and R1. High frequency boost is provided by C10. While the bridge is reverse biased the D1/D2 junction is isolated from the D3/D4 junction, but, when the bridge is forward biased by the sampling pulse, any voltage applied at the D1/D2 junction unbalances the bridge. A voltage approximately equal to the measured signal value appears at the D3/D4 junction, charging C11.

#### 5.3.1.6 Pulse Amplification

- 5.3.1.6.1 During the 300 ps sampling period C11 charges rapidly through the low impedance of the input circuit and the bridge. At the end of the sampling period it discharges through R6 and R5, with a time constant of approximately 1.5  $\mu$ s. The input to the amplifier containing Q1 and Q2 is therefore a pulse, which may be of either polarity, having a sharp leading edge followed by an exponential return to 0 V lasting some 7.5  $\mu$ s. This is buffered by the unity gain stage containing Q1 and Q2, and fed via pin 5 of assembly 19-1011 to R18 on assembly 19-1012.

# SECTION 7

# PARTS LIST AND CIRCUIT DIAGRAMS

---

5.3.1.6.2 Adjustment of R18 controls the final amplitude of the measuring head output pulse, permitting it to be set to a value for which the FACTORY ECAL factor will be within the permitted range. The output pulse is fed via the measuring head cable to the analogue signal processing system.

### 5.3.1.7 Bias Control Circuit

5.3.1.7.1 The sampling bridge is biased such that the diodes are non-conducting, except during the presence of the sampling pulse. The bias level must maintain the bridge balanced symmetrically, about 0 V. If this is not so, excessive sampling pulse breakthrough may occur. This can overload the analogue processing system, particularly in the lower ranges.

5.3.1.7.2 The bias voltages are taken from the resistor chain R13, R11, R12 and R14 on assembly 19-1012. The voltage across this chain is maintained at 20.4 V by diodes D2, D3, D4 and D5. The total bias across the bridge may be set by adjustment of R11, while the bias balanced is set by the voltage applied, through the measuring head cable, to pin 5. This voltage is derived in the second sampler circuit of the analogue signal processing system, on assembly 19-1016.

### 5.3.2 ANALOGUE SIGNAL PROCESSING SYSTEM

5.3.2.1 The analogue signal processing system circuits are carried on two printed circuit boards, assemblies 19-1016 and 19-1015. The circuit diagrams are given in Fig. 9 and Fig. 11 in Section 7 of this manual.

#### 5.3.2.2 Input Multiplexer

5.3.2.2.1 The signal which is to be processed is selected by the input multiplexer, IC7, on assembly 19-1016. The operation of the multiplexer is controlled by the logic levels on the front and rear measuring head selection control lines, which are set by the microprocessor system. The pulse waveforms from the measuring heads enter the board at the coaxial sockets SK9 and SK10. A waveform, simulating the output of a measuring head, and having an amplitude of 1 V peak-to-peak, is fed to IC7/5 from the calibrator system. Only one of these signals will be present at any one time, since sampling pulse drive signals are only fed to the measuring head selected for use, and both measuring heads are disabled while the internal calibrator is enabled during an ACAL sequence.

#### 5.3.2.3 Switched Gain Amplifier

5.3.2.3.1 The selected signal at IC7/14 is passed, via the buffer stage containing Q1 and Q2, to the 30 dB attenuator comprising R4, R5, R6 and R7. The multiplexer IC6 selects either the full output of the buffer stage, from the junction of C43 and R4, or the attenuated signal, from the junction of R5 and R6, as the input to the amplifier containing Q3, Q4 and Q5. The multiplexer is controlled by the logic level on a 30 dB attenuator control line, which is set by the microprocessor system. The attenuator is in circuit when the line is at logic '0'. Adjustment of R4 permits accurate setting of the attenuator.



- 5.3.2.3.2 Three further attenuator/amplifier stages, incorporating attenuators of 30 dB, 20 dB and 10 dB, follow the one described. Although the four stages operate in a similar manner they differ in the following respects:
- (a) The amplifier Q3/Q4/Q5 incorporates filtering circuits C2/R12 and C3/R15. These shape the amplifier response such that, while it is still able to respond efficiently to the sharp leading edge of the input pulse, the output pulse takes approximately 1.5  $\mu$ s to reach its peak value and has an almost flat top.
  - (b) The amplifiers Q9/Q10/Q11 and Q12/Q13/Q14 incorporate catching diodes D8 and D9 to prevent saturation. These are necessary because, should the amplifier saturate, the output signal would be nearly constant. Since AC coupling is used the signal into the next stage would be small, and the auto-ranging system could down range. This would drive the amplifier further into saturation.
  - (c) Two 10 dB attenuators are provided before the final amplifier stage. One of these, formed by R118, R119, R120 and R117, is inserted in the signal path only when the lowest, 316  $\mu$ V, measurement range is in use.
- 5.3.2.3.3 The gain of each amplifier stage is nominally 20 dB. When the 1 V measurement range is in use, the gain between TP7 and TP3 is approximately unity.
- 5.3.2.4 Second Sampler
- 5.3.2.4.1 The second sampler comprises two sample and hold circuits, fed from the output of the switched gain amplifier. One converts the bipolar pulsed output of the amplifier to an AC signal suitable for driving the r.m.s. measuring circuit, while the other provides the control voltage for the measuring head bias balance.
- 5.3.2.4.2 The signal for the r.m.s. measuring circuits is provided by the sample and hold circuit fed via C28. The transmission gate in IC2a is held in the conducting state by a 1.5  $\mu$ s pulse fed, via Q15, from IC13b/12. During this period C19 charges. When IC2a returns to the non-conducting state the voltage on C19 is held, due to the high input impedance of IC1a.
- 5.3.2.4.3 The pulse used to drive IC2a is taken from the VCO which generates the measuring head sampling pulse drive, so that its leading edge is coincident with the sampling pulse. The output of the switched gain amplifier reaches its peak 1.5  $\mu$ s after the sampling of the measured waveform, so that it is this peak value which is held on C19. This value is proportional to the instantaneous value of the measured signal at the instant it is sampled by the measuring head.
- 5.3.2.4.4 The output of the circuit is taken via the voltage follower, IC1a, a high pass filter, C64, R123, and a second voltage follower IC1b. While C19 is being charged the junction of R46 and R47 is held at 0 V by the transmission gate in IC2b. This ensures that the voltage steps fed out to the r.m.s. measuring circuit at the beginning of each hold period all start from the same level.

6.6.7 CALIBRATOR SOCKETS

6.6.7.1 If, for any reason, a CALIBRATOR socket is detached from its panel, care must be taken to ensure that it is remounted correctly when it is replaced. Failure to do so may adversely affect the socket noise performance. The correct assembly of the mounting hardware is shown in Fig. 6.5.

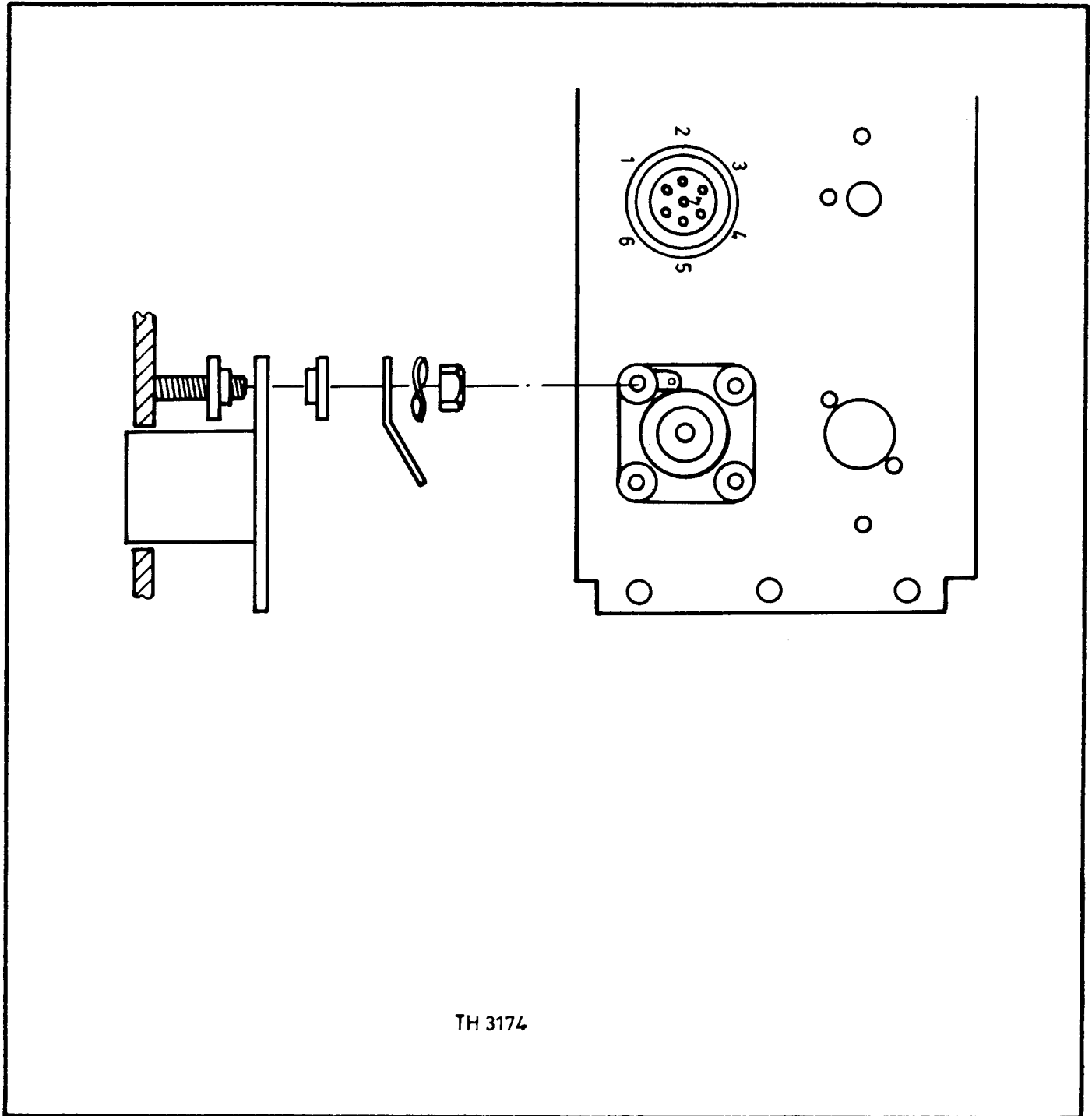

TH 3174

Fig. 6.5 CALIBRATOR Socket Mounting

5.3.2.4.5 Idealised waveforms for the sampling and signal processing systems are given in Fig. 5.2

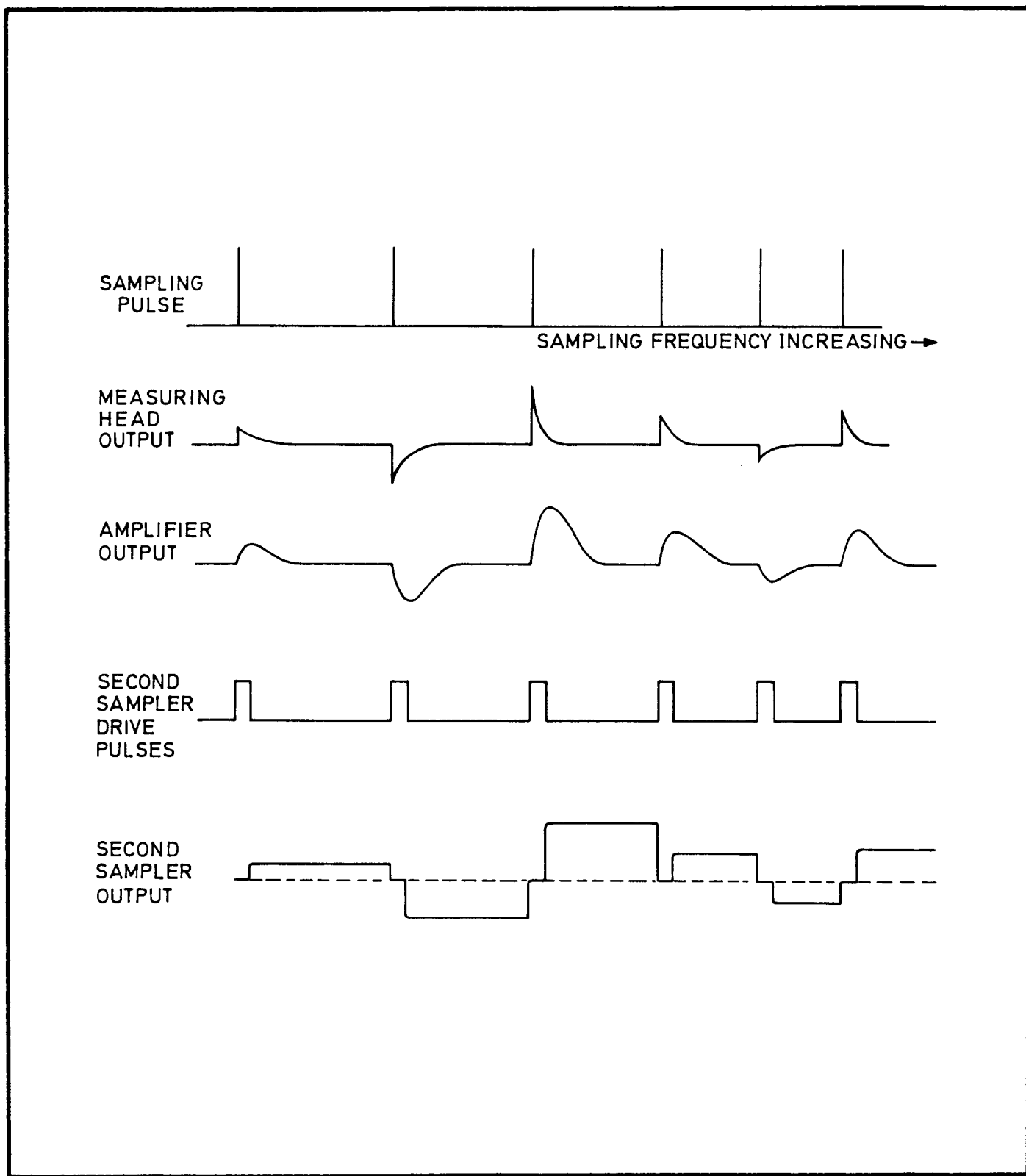

Fig. 5.2 Idealised Waveforms:  
Sampling and Signal Processing



- (b) Clean the contact areas of the LCD using a soft, dry cloth. If necessary a cloth dampened with soapy water may be used to removed grease.
- (c) Clean the display face of the LCD with a soft, dry cloth. An anti-static spray may be used, if required, after cleaning.
- (d) Place the LCD in the front panel aperture, ensuring that the orientation is correct.
- (e) Pull the elastomeric contact strips from the support mouldings and drop the mouldings over the studs. Ensure that they bed down on the front panel, and do not catch on the sides of the LCD.
- (f) Clean the elastomeric contact strips using soapy water. Dry them thoroughly, and replace them in the slots in the support mouldings. Leave the contact strips standing proud of the upper surface of the support mouldings.
- (g) Clean the contacting surface of assembly 19-1013 using iso-propyl alcohol. Refit the assembly as instructed in paragraph 6.6.5.
- (h) Refit the front panel as instructed in paragraph 6.6.4.

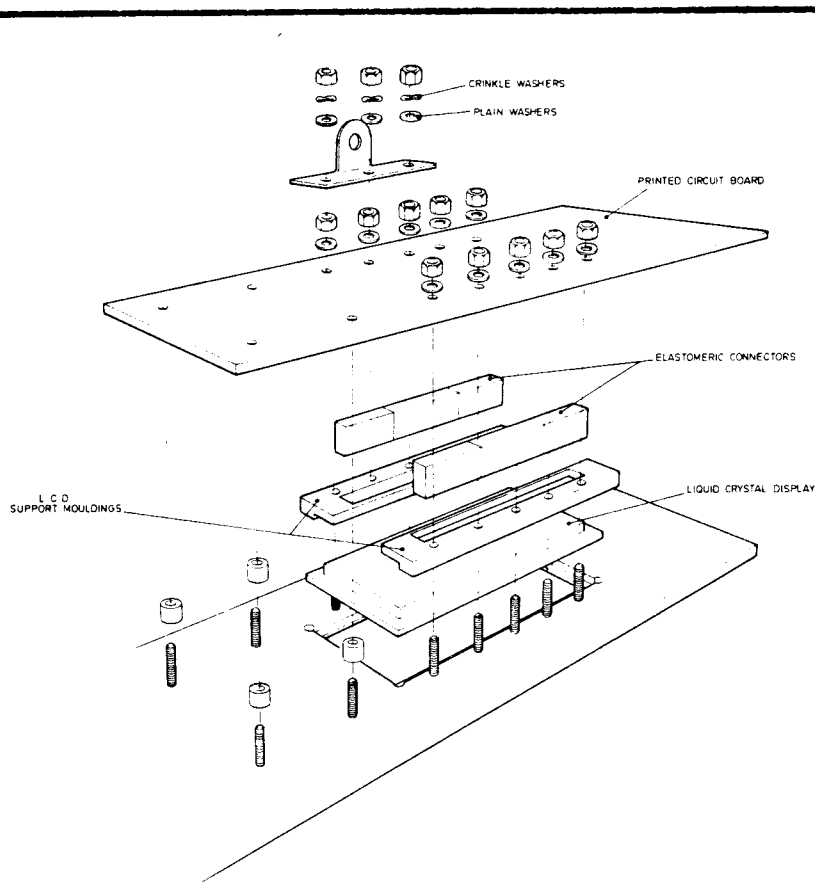

Fig. 6.4 Fitting the Liquid Crystal Display

5.3.2.4.6 If the measuring head bias is not balanced about 0 V, an offset will be added to each sample of the measured signal fed from the measuring head. This will give an offset to the mean level of the input to the second sampler.

5.3.2.4.7 A second sample and hold circuit is fed from the amplifier output via C18. This operates in a similar manner to the circuit previously described. However, it is fed via a circuit of comparatively long time constant, and it does not contain a high pass filter between IC1c and R49 similar to that between IC1a and R46. The output consists of pulses, at the sampling rate, whose mean value is proportional to the mean level of the amplifier output.

5.3.2.4.8 The output from IC1d/8 is fed to the differential input integrator, IC8a. The integrator output is fed, via the voltage follower, IC8b, to the measuring head, where it is used to control the balance of the sampling bridge bias. If a voltage difference exists between IC8a/5 and IC8a/6 a voltage ramp occurs at IC8a/7. The sampling head bias balance will be changed, and this will result in a variation in the mean level of the signal applied to the second sampler. This, in turn, will give a voltage change at IC1d, reducing the voltage difference at the inputs to IC8a. When this difference is reduced to zero the voltage ramp at IC8a ceases. The operating point of the loop can be adjusted by means of R68.

#### 5.3.2.5 True RMS Detector

5.3.2.5.1 The output from IC1b/14, in the sample and hold circuit, forms the input to the true r.m.s. detector on assembly 19-1015. The detector is in the form of a feedback loop containing a multiplier and an integrator. The principle of operation, ignoring the effects of noise and the multiplier input offsets, is given in Fig. 5.3.

5.3.2.5.2 The signal enters the assembly at PL11 pin 4, passing via the gate, Q1, and the voltage follower, IC3, to the inputs to the multiplier IC6/6 and 9. The gate Q1 conducts, except during a period of 10 ms in every 100 ms when the loop auto-zeroing system is operating.

5.3.2.5.3 The multiplier is of the linearised transconductance type, a schematic circuit diagram being given in Fig. 5.4. The operation of the multiplier is covered in Appendix 2 to this section.

## 6.6.5 REMOVAL OF ASSEMBLY 19-1013

6.6.5.1 To remove assembly 19-1013 proceed as follows:

- (a) Remove the front panel, to the limit of its cableform, from the front of the instrument, as instructed in paragraph 6.6.4. Lay the panel, front downwards, flat on the bench.
- (b) Remove the three nuts securing the bracket to assembly 19-1013 and remove the bracket.
- (c) Remove the 14 nuts securing assembly 19-1013 on its support pillars. The assembly can now be lifted clear of the front panel.

CAUTION: Do not touch the contacting surfaces of assembly 19-1013 and the elastomeric contact strips around the LCD on the front panel. Any contamination will lead to poor electrical contact and failure of the LCD elements to function. If the contact strips become contaminated they should be carefully pulled from the slots in the retainers and cleaned with soapy water. The strips must be thoroughly dried before being replaced. If necessary, the contacting surface of assembly 19-1013 should be cleaned using iso-propyl alcohol.

6.6.5.2 The assembly is replaced using the reverse of the above procedure. The securing nuts should be tightened to a torque of 0.34 Nm (3 lbf.in).

## 6.6.6 REPLACEMENT OF THE LCD

6.6.6.1 To remove the LCD proceed as follows:

- (a) Remove the front panel, as instructed in paragraph 6.6.4.
- (b) Remove assembly 19-1013, as instructed in paragraph 6.6.5.
- (c) Lift the LCD support mouldings from the locating studs. The LCD can then be lifted from the aperture in the front panel.

CAUTION: (1) The elastomeric contact strips are free to move in the slots in the support mouldings. Take care they do not fall out.

(2) Avoid all contamination of the elastomeric contact strips with grease from fingers or tools.

6.6.6.2 The fitting of the LCD is illustrated in Fig. 6.4. The fitting procedure is as follows:

- (a) Carefully clean the inside surface of the display viewing window in the front panel. Loose material may be removed using a dry brush. Greasy marks may be removed using a soft, lint-free cloth and iso-propyl alcohol. An anti-static spray may be used, if required, after cleaning.

The inputs to the multiplier are  $(V_S + V_R)$  and  $(V_S - V_R)$

The multiplier output is therefore  $(V_S + V_R)(V_S - V_R)$   
 $= (V_S^2 - V_R^2)$

The integrator output is the mean value of the multiplier output

$$= \overline{(V_S^2 - V_R^2)}$$

The amplifier output is therefore  $A(V_S^2 - V_R^2)$

But the amplifier output is  $V_R$ , so  $\frac{V_R}{A} = \overline{(V_S^2 - V_R^2)}$

If the amplifier gain is large  $\frac{V_R}{A}$  approximates to zero, so that

$$\overline{V_S^2} = \overline{V_R^2}$$

Since  $V_R$  is a direct voltage  $\overline{V_R^2} = V_R^2$ , and

$$V_R = \sqrt{\overline{V_S^2}}, \text{ the r.m.s. value of } V_S.$$

A more complete analysis of the loop operation, taking account of noise and multiplier input offsets is given in Appendix 1 to this section.

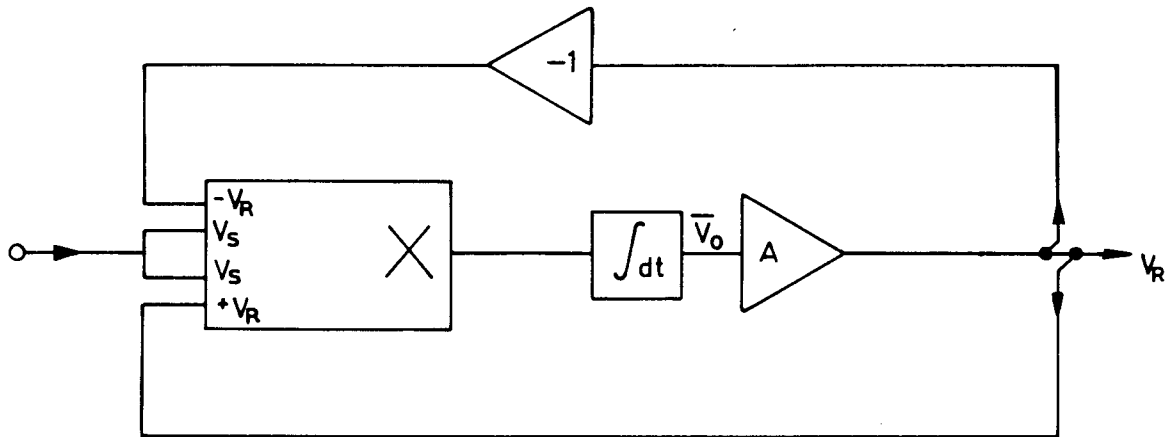

TH3174

Fig. 5.3 Feedback Loop Operation

### 6.6.3.3 When replacing the assembly:

- (a) Ensure that the board is properly located, flat on its supports, before tightening the retaining screws.
- (b) On assembly 19-1016, reconnect the coaxial plugs and insert the ferrite beads in the clip.
- (c) When replacing the module cover, align the threaded collets, which are free to slide in the module side rails, with the holes in the module cover. The head of the cover retaining screws should be tilted slightly towards the front-back centre line of the module when engaging the thread.
- (d) Ensure that the module cover is flat on the module rim when the retaining screws are tightened.

### 6.6.4 REMOVAL OF THE FRONT PANEL

6.6.4.1 The front panel must be removed if access is required to the front face of assembly 19-1013. The panel is removed as follows:

- (a) Remove the instrument covers and the side trim strips.
- (b) Remove the two retaining screws from each front handle and slide the handles out towards the front of the instrument.
- (c) Remove the two screws securing the LINE switch to the inside of the panel. This is most easily done with a round-the-corner screwdriver.
- (d) Remove the screw securing the bracket at the centre front of assembly 19-1014. This screw is removed from the bottom of the instrument.
- (e) Disconnect the ribbon cable 10-2871 between 19-1013 and 19-1014 from 19-1013. (On early model instruments, unsolder the flexible connector from 19-1014).
- (f) Remove the two Taptite (self threading) screws from each end of the front panel. The panel can now be drawn forward to the limit of the cable form to the CALIBRATOR and INPUT sockets.

6.6.4.2 To replace the panel follow the reverse of the above procedure.

**CAUTION:** Do not interchange the Taptite screws with machine threaded screws. The Taptite screws will damage the thread in any machine threaded holes into which they are inserted. Machine threaded screws will not hold the front panel securely.

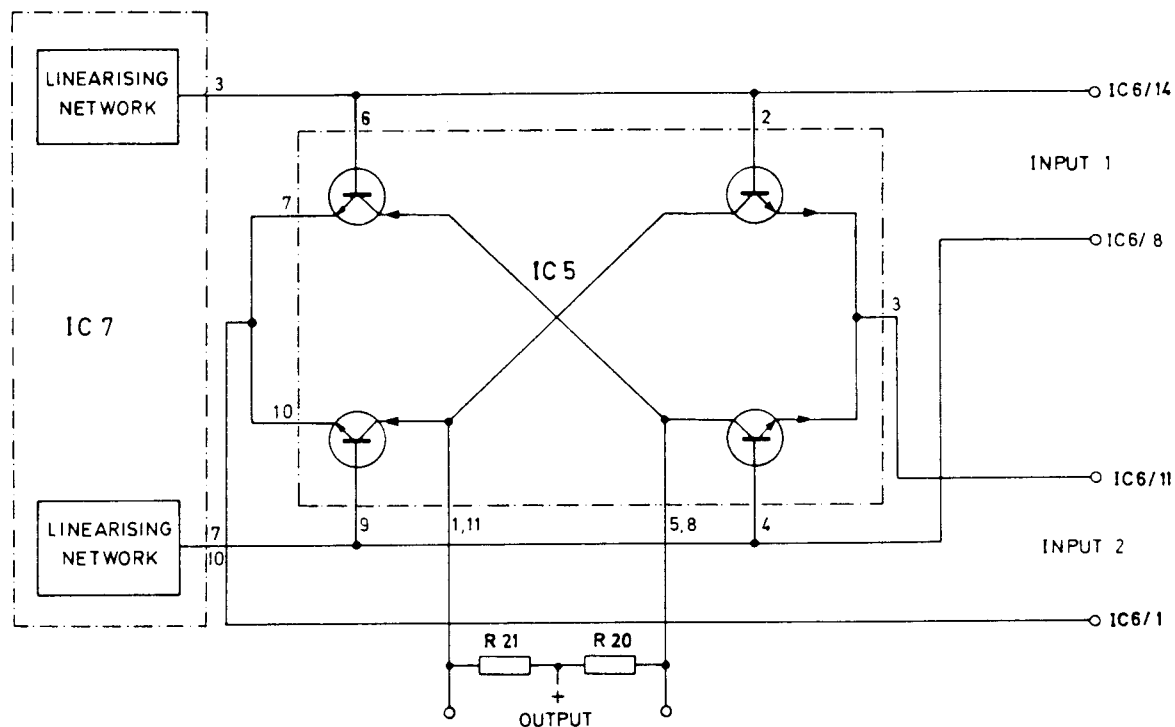

Fig. 5.4 Multiplier

5.3.2.5.4 The transistors of the multiplier are contained in IC5. The use of the transistor array, rather than discrete components, affords close matching of the transistor characteristics. IC5 is specially selected to obtain the degree of matching required. The multiplier linearising networks are formed by the transistors in IC7. This array is also specially selected to obtain the required degree of matching. The base/emitter diodes of these transistors form the loads for the input currents from IC6 pins 8 and 14. They provide an exponential relationship between the input currents and the voltages applied at IC5 pins 4, 9, 2 and 6, which offsets similar non-linearities in the transistors of IC5.

5.3.2.5.5 The multiplier inputs are driven by the transistors in IC6, which are connected, with two of the transistors from IC5 and IC7, to form two long-tailed-pair differential amplifiers. Good matching of these transistors is essential, and IC6 is specially selected to achieve this. When measuring signals of high crest factor the differential signal at the amplifier inputs becomes large, and the transistors may be driven close to cut off at the signal peaks. This results in non-linearity. The effect is overcome by means of D4 and D5, which conduct when the differential signal is large, reducing the emitter coupling resistor value and increasing the amplifier gain.

- (d) Set the signal generator frequency to 100 MHz, 300 MHz, 500 MHz, 1.0 GHz, 1.5 GHz and 2.0 GHz in turn, repeating steps (a) to (c) at each step.
- (e) Switch off the 9303 and disconnect the test equipment.

## 6.6 DISMANTLING AND REASSEMBLY

### 6.6.1 INTRODUCTION

- 6.6.1.1 Instructions for dismantling and reassembling the 9303 are limited to those areas where special care is required or difficulty may be experienced.

WARNING: THE INSTRUMENT MUST BE SWITCHED OFF AND DISCONNECTED FROM THE AC SUPPLY DURING ALL DISMANTLING AND REASSEMBLY OPERATIONS.

### 6.6.2 REMOVAL AND REPLACEMENT OF THE COVERS

- 6.6.2.1 (a) Switch off the instrument and the AC supply. Remove the line power socket.
- (b) Stand the instrument on its front handles, and remove the two screws from each of the plastic mouldings at the rear corners of the instrument. Remove the mouldings.
- (c) The covers can now be removed by sliding them towards the rear of the instrument. Note that the removal of the plastic mouldings also releases the side trim panels, which should either be removed or secured by replacement of the mouldings.
- (d) The covers are replaced in the reverse manner. Note that the straight, unfolded edge of the cover fits to the front of the instrument, and locates in a groove in the rear face of the front panel. The rear edge of the cover is folded under, and locates in a groove in the rear panel.

### 6.6.3 REMOVAL OF ASSEMBLIES 19-1015 and 19-1016

- 6.6.3.1 These assemblies are contained in the screening module. Once the instrument covers have been removed the appropriate module cover (the upper for 19-1015 and the lower for 19-1016) can be released by removing the six retaining screws. This will provide sufficient access for test purposes.

- 6.6.3.2 If access to the unexposed side of an assembly is required, proceed as follows:-

- (a) If removing 19-1016, unplug coaxial plugs from SK7, 8, 9 and 10 and lift the ferrite beads on the cable to SK7 from the clip.
- (b) Remove the six screws holding the board onto its supports within the module. This will enable the assembly to be tilted and lifted out of the module to the extent of the remaining connections. This provides adequate access for servicing.

- 5.3.2.5.6 The differential output from the multiplier is fed to IC4d. Except during the auto-zeroing period Q3 and Q4 are held in the conducting state, while Q10 and Q8 are in the high impedance state. Feedback is therefore applied to IC4d via C20, and the circuit acts as an integrating amplifier. The voltage at TP6 is proportional to the mean level of the multiplier output, and to the true r.m.s. value of the measured signal.
- 5.3.2.5.7 The output of IC4d is fed back to the input of the multiplier at IC6/2 and IC6/12. The feedback circuit is shown in Fig. 5.5.

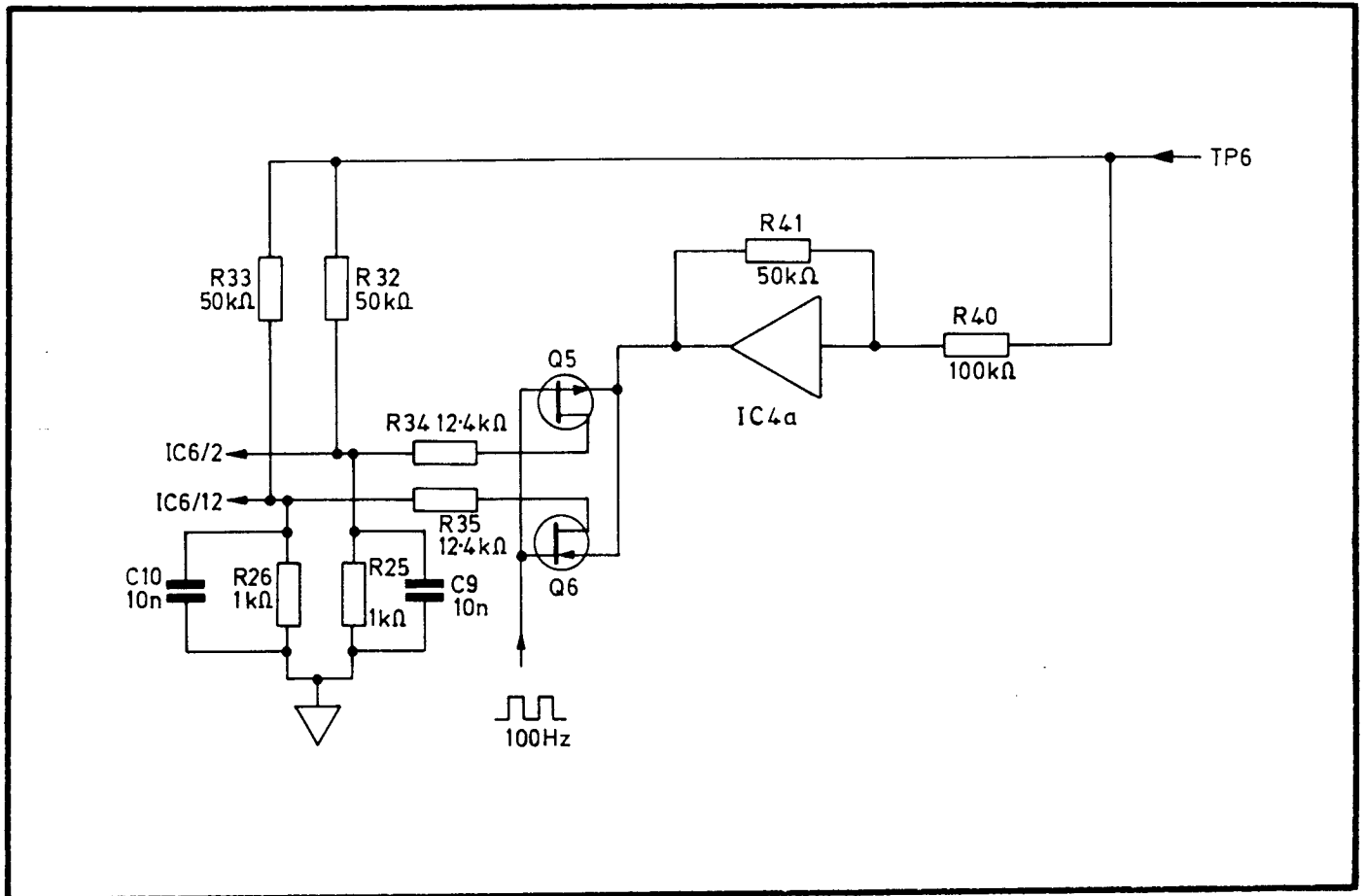

Fig. 5.5 Feedback Switching

- 5.3.2.5.8 The feedback from TP6 to IC6/2 and IC6/12 is in two parts:
- A positive voltage, fed to both IC6/2 and IC6/12 via R32 and R33.
  - A negative voltage fed via IC4a, Q5/Q6 and R34/R35. This is fed to IC6/2 or IC6/12, according to whether Q5 or Q6 is conducting, and is switched between these inputs at 100 Hz.
- 5.3.2.5.9 The gain of IC4a is set by R40 and R41 to 0.5, and the resistance ratios R35/R33 and R34/R32 are 0.25. The negative signal is therefore twice the positive signal, and IC6/2 and IC6/12 receive signals of equal amplitude but opposite sign. The switching transistors are driven from the 100 Hz clock in the microprocessor system via IC1d.



TABLE 6.17

VSWR Return Loss

Frequency	Spectrum Analyser Indication with Measuring Head Connected to VSWR Bridge
100 MHz	- (>27 dB)
500 MHz	- (>27 dB)
1.0 GHz	- (>27 dB)
1.5 GHz	- (>14.5 dB)
2.0 GHz	- (>14.5 dB)

- (d) Exchange the female VSWR bridge for the male bridge.
- (e) Remove the matched 50  $\Omega$  load from the measuring head, and terminate the input port with the additional 50  $\Omega$  load.
- (f) Set the signal generator output to 100 MHz and repeat steps (a) to (c).
- (g) Disconnect the test equipment.

6.5.20 INSERTION LOSS

6.5.20.1 Test equipment required:

<u>Description</u>	<u>Table 6.8 Item No.</u>
Signal Generator	4
Power Meter	5
Attenuator pads (2)	8

6.5.20.2 Connect the 9303 measuring head to the INPUT socket calibrated for its use. Select FRONT or REAR as appropriate. Fit the power sensor to the power meter, and connect it to the signal generator output via two 10 dB attenuator pads. Set the signal generator output to a frequency of 30 MHz.

- 6.5.20.3 (a) Adjust the signal generator output level to give an indication of -10 dBm on the power meter.
- (b) Connect the measuring head in line between the two 10 dB attenuator pads. Check that the power meter indication +10 dBm agrees with the insertion loss figure shown on the measuring head calibration label against the signal generator frequency.
- (c) Remove the measuring head from the circuit and reconnect the two attenuators.

### 5.3.2.6 Output Sample and Hold

5.3.2.6.1 The voltage at TP6 is proportional to the true r.m.s. value of the measured signal. Except during the auto-zeroing period Q9 is in the low impedance state, and C23 charges to this value. The voltage is fed to the digital signal processing system via the voltage follower, IC4b. During the auto-zeroing period Q9 is put to the high impedance state and the output voltage is maintained at the level held on C23.

### 5.3.2.7 Auto-Zeroing

5.3.2.7.1 Every 100 ms an auto-zeroing cycle, lasting 10 ms, is performed. During this period the measured signal input is reduced to zero, and the residual signal at the output of IC4d is used to generate a correction voltage, which is stored. During the 90 ms measurement period which follows, this voltage is injected into the feedback loop of the r.m.s. detector, cancelling the zero error.

5.3.2.7.2 The timing of the auto-zeroing system is controlled by the waveform from IC2/3 in the timing and sweep generator circuit. This waveform, derived from the 100 Hz clock on assembly 19-1014, consists of 10 ms positive-going pulses occurring at 10 Hz, and is applied to the comparators, IC1b and IC1c.

5.3.2.7.3 The edges of the pulses are slowed down by the low-pass filter, R37/C17. A resistor chain, formed by elements of R36 and R37, holds IC1b/6 more positive than IC1c/10, so the comparators are not triggered simultaneously. Idealised waveforms are shown in Fig. 5.6.

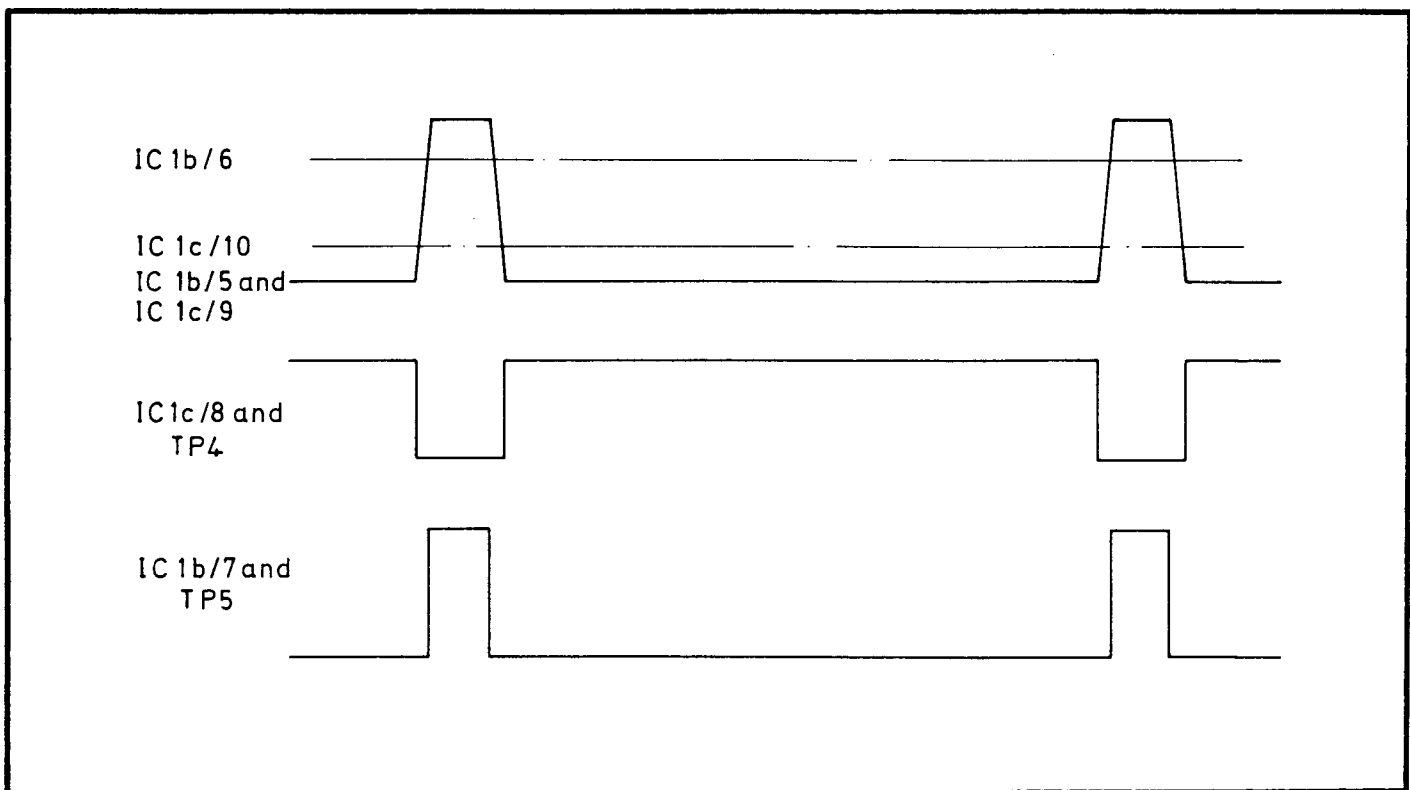

Fig. 5.6 Comparator Waveforms

(f) Check that the indications recorded in step (c) agree with the calibration curve on the measuring head to within  $\pm 1.5\%$ .

(g) Disconnect the test equipment.

### 6.5.19 VSWR CHECK

#### 6.5.19.1 Test equipment required:

<u>Description</u>	<u>Table 6.8 Item No.</u>
Signal Generator	4
Spectrum Analyser	6
VSWR Bridge (Male)	8
VSWR Bridge (Female)	8
50 $\Omega$ Load	10

6.5.19.2 Connect the signal generator to the INPUT port and the spectrum analyser to the OUTPUT Port of the female VSWR bridge as shown in Fig. 6.3. Do not connect the measuring head to the UNKNOWN port. Set the signal generator output to 100 MHz at a level of 0 dBm. Set the spectrum analyser to measure relative power (logarithmic mode). Connect the 9303 measuring head to the INPUT socket calibrated for its use. Terminate the head with the matched 50  $\Omega$  load. Select FRONT or REAR as appropriate.

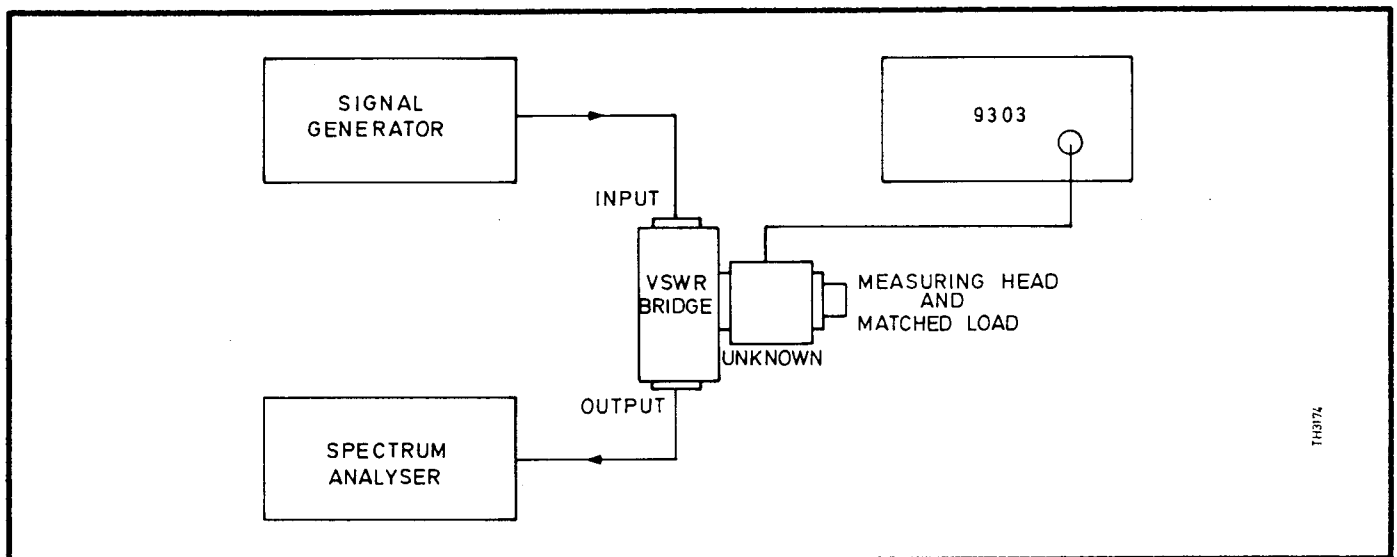

Fig. 6.3 Connections for VSWR Check

- 6.5.19.3 (a) Adjust the spectrum analyser input attenuator and logarithmic reference level controls until the display is set to a suitable reference level.
- (b) Connect the measuring head to the UNKNOWN port of the VSWR bridge and check that the indication on the spectrum analyser is as given in Table 6.17.
- (c) Disconnect the measuring head from the VSWR bridge. Adjust the signal generator frequency to the next value given in the table and repeat steps (a) to (c).

5.3.2.7.4 At the commencement of the auto-zeroing period the following actions are performed by the pulses from IC1b and IC1b:

- (a) The negative-going pulse from IC1c puts Q1 to the high impedance state, isolating the r.m.s. detector loop input.
- (b) Q9 is put to the high impedance state, isolating the loop output.
- (c) Q3 and Q4 are put to the high impedance state, preventing feedback around IC4d via C20.
- (d) Q10 is put to the low impedance state, allowing feedback around IC4d via C25.
- (e) Q8 is put to the low impedance state. This connects the residual loop output, which exists at IC4d/14 when the loop input is open circuited, to the integrator, IC4c. The output of IC4c is applied to IC4d/12, providing an input which drives the output of IC4d to 0 V.

5.3.2.7.5 At the end of the auto-zeroing period the circuit is reset to the measurement mode. The input of IC4c is disconnected from the signal path, as Q8 reverts to the high impedance state, but the zero error correction voltage at TP15, stored in C18, remains connected to the input of IC4d. This provides zero correction during the following measurement period.

#### 5.3.2.8 Prevention of Lock Up

5.3.2.8.1 When the instrument is operated with no input signal, there may be a tendency for the output of the loop to drift negative. If such an output is fed back to the multiplier the effect is cumulative, and the loop locks up with the output driven negative. This is prevented by D10, which becomes reverse biased if the voltage at TP6 is negative, so open circuiting the feedback path.

### 5.3.3 THE MICROPROCESSOR SYSTEM

5.3.3.1 The microprocessor system is carried on assembly 19-1014. The circuit diagram is given in Fig. 7 in Section 7 of this manual.

5.3.3.2 The system acts as a digital signal processing system and as the instrument control system. The digital signal processing function includes the following:

- (a) Conversion of the true r.m.s. detector output to digital form, and reading the digitised measurement.
- (b) Scaling the measurement according to the values held in the ACAL and FACTORY ECAL stores (and the USER ECAL and CAL FACTOR stores if these are enabled).
- (c) Averaging a number of measurements according to the value in the AVERAGE store.

TABLE 6.15

Frequency Response Check Points

Frequency
500 kHz
1 MHz
10 MHz
30 MHz
100 MHz
300 MHz
500 MHz
1 GHz
1.5 GHz
2 GHz

- 6.5.18.4 Connect the DVM to measure the output of the thermocouple. Set the signal generator output to 500 kHz.
- 6.5.18.5 (a) Connect the thermocouple to the signal generator output. Adjust the signal generator output level to 0 dBm. Note the reading on the DVM.
- (b) Connect the measuring head to the signal generator output in place of the thermocouple. Press /STORE//RATIO//RATIO/.
- (c) Record the indication on the 9303. Change the signal generator frequency to the next value given in Table 6.16.
- (d) Connect the thermocouple to the signal generator output in place of the measuring head, and adjust the signal generator output to obtain the same indication on the DVM as was obtained in (a).
- (e) Connect the measuring head to the signal generator output and repeat steps (c) to (e) until measurements have been made at each frequency.

TABLE 6.16

Frequency Response Check Points

Frequency
500 kHz
100 kHz
50 kHz
10 kHz

- (d) Noise cancellation, according to the noise level measured during the FACTORY ECAL and USER ECAL sequences.
- (e) Arithmetic processing in accordance with the primary and computed measurement functions set by the control system.
- (f) Conversion of the processed data into a serial data string for the display.
- (g) Conversion of the processed data into the 12-byte data word to be fed to the GPIB interface.
- (h) Transmission of the serial data string to the display, accompanied by the clock pulses for the output system shift registers.
- (j) Transmission of the 12-byte data word to the GPIB interface.

5.3.3.3 The instrument control function includes the following:

- (a) Acceptance of control instructions from the keyboard or the GPIB interface.
- (b) Acceptance and storage of numerical data from the keyboard or the GPIB interface.
- (c) Setting the attenuator control line logic levels.
- (d) Setting the measuring head control line logic levels.
- (e) Enabling and disabling the calibrator system, and directing the measurements made during calibration cycles to the appropriate stores.

#### 5.3.3.4 Analogue to Digital Conversion

- 5.3.3.4.1 The analogue signal from the true r.m.s. detector enters assembly 19-1014 at PL15 pin 16. It passes via a bilateral switch in IC8 to the input of the analogue-to-digital converter, IC9. The output of the converter is in the form of  $3\frac{1}{2}$  digits in BCD on 13 lines, and is fed to the Peripheral Interface Adaptor (PIA), IC12, at pins 2 to 14. Additional signals are fed to IC12/16, 17 and 18 to indicate that the conversion cycle has been completed, and to IC12/15 to indicate that the output data from IC9 is valid.
- 5.3.3.4.2 A 100 Hz clock signal for IC9 is taken from an astable circuit at IC3/14, and used to drive a monostable circuit, IC14b. The output pulses at IC14/5 have a duration controlled by R9 and C7.
- 5.3.3.4.3 The positive and negative supply voltages for IC9 are derived from the +15 V and -15 V supply rails across D15 and D14. The current reference to IC9/13 can be adjusted, by means of R15, to set the full scale gain of the converter.

6.5.18 FREQUENCY RESPONSE

6.5.18.1 Test equipment required:

<u>Description</u>	<u>Table 6.8 Item No.</u>
Digital Voltmeter	2
Signal Generator	4
Power Meter	5
Attenuator	8
Thermocouple	11

6.5.18.2 Connect the measuring head to the INPUT socket calibrated for its use. Terminate the measuring head with the matched 50  $\Omega$  load. Select FRONT or REAR, as appropriate. Fit the power sensor to the power meter. Connect the attenuator pad to the signal generator output, and set the output to a frequency of 500 kHz.

- 6.5.18.3
- (a) Connect the power sensor to the output of the attenuator. Adjust the signal generator output level to obtain an indication of 0 dBm on the power meter.
  - (b) Connect the measuring head to the attenuator output in place of the power sensor. Press /STORE//RATIO//RATIO/.
  - (c) Record the indication on the 9303. Change the signal generator frequency to the next value given in Table 6.15.
  - (d) Connect the power sensor to the attenuator output in place of the measuring head. Set the signal generator output to give an indication of 0 dBm on the power meter.
  - (e) Connect the measuring head to the attenuator output in place of the power sensor, and repeat steps (c) to (e) until measurements have been made at each frequency.
  - (f) Check that the indications recorded in step (c) agree with the calibration curve on the measuring head to within the following limits:  
  
Below 500 MHz  $\pm$  1.5 %  
500 MHz to 2 GHz  $\pm$  2.5 %
  - (g) Disconnect the test equipment.

### 5.3.3.5 Digital Data Input

5.3.3.5.1 The digital data output from IC9 is fed to the data-in registers of the PIA, IC12. At the end of each analogue-to-digital conversion cycle of IC9, IC12/18 is put to logic '0'. This results in the generation of an  $\overline{\text{IRQ}}$  signal at IC12/37. The microprocessor enters its interrupt routine, during which it establishes that IC12 was the source of the interrupt, and then reads the data from the PIA.

### 5.3.3.6 Digital Data Processing

5.3.3.6.1 The digital data processing operations given in sub-paragraphs 5.3.3.2(b) to (j) are carried out by the microprocessor in accordance with the instructions in the system software, where necessary using numeric values held in memory. A description of the software is considered unnecessary for the purposes for which this manual is intended.

### 5.3.3.7 Serial Data Output to the Display

5.3.3.7.1 Once the value to be displayed has been determined it is used, together with data regarding the non-numeric items to be displayed, to set up the 96-bit data string used to update the display. This data string is fed to the keyboard/display system on the microprocessor data line D0, via IC36a to d and IC33c.

5.3.3.7.2 A series of 96 clock pulses is sent in synchronism with the data string, 32 pulses being directed to each of the display clock lines in turn. The clock pulses are directed to the required lines by IC32, according to the levels set on IC32/1, 2 and 3 by the address lines A0, A1 and A2. The enablement of IC32 is controlled by the chip select circuit, which sets the logic level at IC32/4.

### 5.3.3.8 Parallel Data Output to the GPIB Interface

5.3.3.8.1 After the display has been updated, the measured value is converted to the format required for the GPIB interface output message. The first byte is passed to the data-out register of the General Purpose Interface Adaptor (GPIA) chip on assembly 19-1017.

5.3.3.8.2 When the first data byte has been read from the data-out register to the bus the GPIA chip generates an interrupt request. The microprocessor then transfers a further byte. This process is repeated until the final byte has been transferred.

### 5.3.3.9 Data Input from the GPIB Interface

5.3.3.9.1 The data input from the GPIB interface also takes place byte by byte under interrupt control. When a byte has been written into the data-in register of the GPIA chip from the bus, an interrupt request will be generated. The microprocessor interrupt routine will establish the reason for the interrupt, and the data will be transferred to the microprocessor.



- (d) Press /STORE//SHIFT//EXT. CAL/. Wait until the resulting USER ECAL cycle is complete.
- (e) Enable the USER ECAL factor by pressing /SHIFT//EXT. CAL/.  
*Press Continue*
- (f) Switch on the signal generator and set the output level to that set in paragraph 6.5.17.2.
- (g) Vary the attenuator to set the input level to the 9303 to each of the values given in Table 6.14 in turn. At each stage check that the 9303 has auto-ranged to the correct range and gives the correct measurement indication.
- (h) Disconnect the test equipment.

TABLE 6.14

Accuracy Check

Attenuator Setting	Attenuator Output		9303 Range	Indication
	dBm	dBV		
76 86	-57 -67	-70 -80	316.2 $\mu$ V	316.2 $\mu$ V $\pm$ 5.6 $\mu$ V 100.0 $\mu$ V $\pm$ 3.5 $\mu$ V
66 76	-47 -57	-60 -70	1 mV	1.000 mV $\pm$ 0.009 mV 0.316 mV $\pm$ 0.004 mV
56 66	-37 -47	-50 -60	3.162 mV	3.162 mV $\pm$ 0.027 mV 1.000 mV $\pm$ 0.011 mV
46 56	-27 -37	-40 -50	10 mV	10.00 mV $\pm$ 0.09 mV 3.16 mV $\pm$ 0.03 mV
36 46	-17 -27	-30 -40	31.62 mV	31.62 mV $\pm$ 0.27 mV 10.00 mV $\pm$ 0.11 mV
26 36	-7 -17	-20 -30	100 mV	100.0 mV $\pm$ 0.9 mV 31.6 mV $\pm$ 0.3 mV
16 26	+3 -7	-10 -20	316.2 mV	316.2 mV $\pm$ 2.7 mV 100.0 mV $\pm$ 1.1 mV
6 16	+13 +3	0 -10	1 V	1.000 V $\pm$ 0.009 V 0.316 V $\pm$ 0.003 V
0 6	+19 +13	+6 0	3.162 V	2.000 V $\pm$ 0.030 V 1.000 V $\pm$ 0.020 V

5.3.3.9.2 When the first byte has been read by the microprocessor, the GPIA chip is able to accept a further byte from the bus. When this has been written into the data-in register a further interrupt request is generated. The process is repeated until no further data are available.

#### 5.3.3.10 Data Input from the Keyboard

5.3.3.10.1 Each operation of a key generates an interrupt request. The microprocessor interrupt routine will establish the keyboard as being the source of the interrupt, and the keyboard servicing routine which follows will detect which key has been operated. A data byte, determined by the key operated, is stored, and the  $\overline{\text{IRQ}}$  control line is reset.

5.3.3.10.2 The LED indicators associated with the control keys are operated immediately the data input occurs, and the digits associated with a numerical data input are displayed as the bytes are stored. In other respects the processing of a multi-byte input does not commence until a valid terminating byte is recognised.

5.3.3.10.3 The generation of the  $\overline{\text{IRQ}}$  signal is performed by IC27 and IC31a. The key row lines are normally held at logic '0' by IC37 a, b, c and d, while the column lines are pulled to logic '1' by the resistors in R30. The operation of a key pulls one of the column lines to logic '0' and puts IC27/8 to logic '1', clocking IC31a/6 to logic '0'. This output, buffered by IC33d, forms the  $\overline{\text{IRQ}}$  signal.

5.3.3.10.4 The keyboard servicing routine commences with IC28/1 and 19 being put to logic '0', and IC37/2, 5, 9 and 12 being put to logic '1', by the chip select circuit. Both devices are then in the enabled state. The microprocessor address lines A0, A1, A2 and A3 are first put to logic '1', and then used to set each keyboard row line to logic '0' in turn via IC37 a, b, c and d. When the row line associated with the key which has been operated is put to logic '0', the column line for that switch will also be put to logic '0'. The corresponding output of IC28 will go to logic '1', providing a data byte on the bus which, considered in conjunction with the logic levels on address lines A0, A1, A2 and A3 is unique to the operated key. This byte is transferred into the microprocessor.

5.3.3.10.5 When the byte from the keyboard has been loaded, IC31a is cleared by a logic '0' level applied to IC31a/1 from the chip select circuit. This clears the interrupt request.

#### 5.3.3.11 Attenuator, Measuring Head and Calibrator Control

5.3.3.11.1 The logic levels on the control lines for the attenuators of the variable gain amplifier, measuring head selection and the calibrator are set by transferring data into the data-out register of the control PIA, IC11.

5.3.3.11.2 The control lines are driven from the peripheral data bus ports of IC11. The levels remain set when IC11 is deselected at the completion of the data transfer. The outputs from IC11 are buffered in IC4, IC5 and IC6.

#### 5.3.3.12 The Chip Select Circuit

5.3.3.12.1 The logic levels for chip selection within the system are generated in a circuit containing IC25, IC26 and IC34. The valid memory address (VMA) line from IC30/5 is used to enable IC25 whenever chip selection is required.

*Performance Check*

TABLE 6.13

Linearity Check

Signal Generator Output Level		9303 Indication
0.1 V Steps	1 dB Steps	
1 V	+13 dBm	1.000 ± 0.001
0.9 V		.9000 ± 0.002
	+12 dBm	.8913 ± 0.002
0.8 V		.8000 ± 0.002
	+11 dBm	.7943 ± 0.002
	+10 dBm	.7079 ± 0.002
0.7 V		.7000 ± 0.002
	+9 dBm	.6310 ± 0.002
0.6 V		.6000 ± 0.002
	+7 dBm	.5012 ± 0.003
0.5 V		.5000 ± 0.003
0.4 V		.4000 ± 0.003
	+5 dBm	.3981 ± 0.003
	+3 dBm	.3162 ± 0.003
0.3 V		.3000 ± 0.003

6.5.17 ACCURACY CHECK

6.5.17.1 Test equipment required:

<u>Description</u>	<u>Table 6.8 Item No.</u>
Signal Generator	4
Switchable Attenuator	9

6.5.17.2 Connect the measuring head to the INPUT socket, calibrated for its use. Terminate the head with the matched 50 Ω load and connect it to the attenuator output. Connect the attenuator input to the signal generator output. Set the attenuator to 19 dB and set the signal generator output to a frequency of 500 kHz at level giving 0 dBm ± 0.008 dB from the attenuator output.

- 6.5.17.3
- (a) Switch on the 9303. Select FRONT or REAR, as appropriate, and the auto-ranging mode.
  - (b) Press /STORE//SHIFT//EXT CAL/. Wait until the resulting USER ECAL cycle is complete.
  - (c) Switch off the signal generator output, and set the output to minimum level.

- 5.3.3.12.2 The ROM enabling signals (logic '0' level) are obtained directly from IC25/7, 9, 10 or 11, according to the logic levels applied to IC25/1, 2 and 3 by the microprocessor via address lines A12, A13 and A14. For all other chip enabling signals these address lines are set to give a logic '0' at IC25/15, which is used to enable IC26.
- 5.3.3.12.3 When enabled, IC26 generates one of the following outputs, according to the logic levels set on address lines A10, A9 and A8 by the microprocessor.
- (a) The RAM selection signal (M)
  - (b) The keyboard servicing enablement for IC28 and IC37.
  - (c) The display clock enablement ( $\overline{\text{OPE}}$ ) for IC32
  - (d) The enablement for IC22 or IC29
  - (e) The enablement for IC34.
- 5.3.3.12.4 When enabled IC34 generates the enabling signal for the PIAs IC11 and IC12, or for the GPIA chip in the GPIB interface, ( $\overline{\text{GCS}}$ ), according to the logic levels set on address lines A6, A5 and A4 by the microprocessor.

#### 5.3.3.13 Reset and Memory Supply Changeover Circuit

- 5.3.3.13.1 When the power supply to the instrument is off IC43, IC44, IC45, IC42 and IC15 are powered from the battery, B1. The voltage level detectors IC44 and IC45 detect the low voltage on the +5 V supply rail, and both IC45/6 and IC44/5 are at logic '0'. As a result IC42a/3 and IC42d/13 are at logic '1'. The bistable circuit formed by IC15b and IC15c will have been reset when the instrument supply was switched off, leaving IC15c/8 at logic '1'. Both inputs to IC42d are therefore at logic '1', and IC42d/11 ( $\overline{\text{RESET}}$ ) is held at logic '0'. The logic '1' at IC15c/8 also holds the R/W line in the read condition and the RAM select line at logic '1', via IC43b and IC43c, so preventing access to the memory.
- 5.3.3.13.2 When power is applied the potential on the +5 V rail increases until IC45/6 and IC44/5 go to logic '1', and IC42a/3 goes to logic '0'. As a result IC42d/11 goes to logic '1', releasing the microprocessor from reset, while IC42c/10 goes to logic '1'. As part of its start-up procedure the microprocessor sets a logic '1' at IC11/19, and, therefore, at IC42c/9. The bistable circuit, IC15b and IC15c, is put to the set state, with IC15c/8 at logic '0', releasing the R/W and  $\overline{\text{CS}}$  lines.
- 5.3.3.13.3 When power to the instrument is switched off or fails the reduction in the voltage on the +5 V supply rail is sensed by IC44, and IC44/6 goes to logic '1'. Since IC15d/12 is already held at logic '1' by IC15b, IC15d/11 goes to logic '0', providing a non-maskable interrupt ( $\overline{\text{NMI}}$ ) at IC30/6. At the completion of the current instruction the microprocessor enters its non-maskable interrupt routine. As part of this routine a logic '0' is set at IC11/39, and applied to IC15c/9. This puts the bistable circuit formed by IC15b and IC15c to the reset state, with IC15c/8 at logic '1'. The R/W line is held in the read state and the RAM select line is held at logic '1' via IC43b and IC43c, so preventing corruption of the memory contents with spurious data which may be generated during the power fade period.

6.5.16 LINEARITY ADJUSTMENT

6.5.16.1 Test equipment required

<u>Description</u>	<u>Table 6.8 Item No.</u>
Signal Generator	4
Switchable Attenuator	9

6.5.16.2 Connect the measuring head to the INPUT socket calibrated for its use. Terminate the head with the matched 50  $\Omega$  load, and connect it to the output of the attenuator. Set the attenuator to 20 dB, and connect the attenuator input to the signal generator output. Set the signal generator to an output of 500 kHz at a level giving -7 dBm at the attenuator output. Set the attenuator to 0 dB.

- 6.5.16.3
- (a) Press /RECALL//0//0/. Select the manual ranging mode, and step through to the 1 V range. Press /5//STORE//SHIFT//AVERAGE/. Select FRONT or REAR as appropriate.
  - (b) Press /STORE//RATIO//RATIO/. This will store the displayed value in the RATIO store and put the 9303 to the ratio measurement function.
  - (c) Reset the attenuator to 20 dB.
  - (d) If necessary, adjust R24 on assembly 19-1015 until the 9303 indicates  $.1000 \pm 0.002$ .
  - (e) Reset the attenuator to 10 dB and check that the 9303 indicates  $.3162 \pm 0.002$ .
  - (f) If R24 was adjusted in (d), reset the attenuator to 0 dB and repeat stages (b) to (e) until the correct indications are obtained.
  - (g) Reset the attenuator to 0 dB, and then reduce the output in steps of 0.1 V or 1 dB. At each step check that the 9303 indication is as given in Table 6.13.
  - (h) Switch off the 9303 and disconnect the test equipment. Replace the instrument covers.

#### 5.3.3.14 Test Switchbank S30

- 5.3.3.14.1 The switchbank S30 is used to set a pattern onto the data bus for test purposes, and to indicate to the microprocessor that the GPIB interface is fitted. In normal operation switches 1 to 7 must be set to the open position (where the slider is furthest from the switch section number). Switch 8 must be closed.

#### 5.3.4 THE KEYBOARD/DISPLAY SYSTEM

- 5.3.4.1 The system comprises a 7 x 4 - line keyboard, a liquid crystal display (LCD) and a number of light emitting diode (LED) indicators. Although the LED indicators are related to particular keys, all connection between the keyboard and the display is via the microprocessor system.

- 5.3.4.2 A 30 Hz switching waveform for the LCD is generated by IC3d and IC31b on assembly 19-1014. The remainder of the system is mounted on assembly 19-1013. The circuit diagrams are given in Fig. 5 and Fig. 7 in Section 7 of this manual.

#### 5.3.4.3 The Keyboard

- 5.3.4.3.1 The keyboard switches are of the mechanical, push-operated type. When the microprocessor is not servicing the keyboard all four row lines, entering assembly 19-1013 at pins 7, 8, 11 and 12, are held at logic '0', while the seven column lines, entering the assembly at pins 13 to 19, are held at logic '1'.

- 5.3.4.3.2 Closure of any switch will result in the corresponding column line being pulled to logic '0'. This action generates a IRQ for the microprocessor, which will then service the keyboard. The generation of the IRQ and the keyboard servicing procedure are described in the description of the microprocessor system.

#### 5.3.4.4 The Liquid Crystal Display

- 5.3.4.4.1 The LCD is a custom built device having 79 segments. The information to be displayed is fed from the microprocessor in the form of a 96-bit data string. This enters assembly 19-1013 at pin 22, and is applied to the data input pins of the shift registers, IC1, IC2 and IC3, in parallel. The clock lines for the shift registers enter the assembly at pins 20, 21 and 10. The waveforms on these lines are controlled by the microprocessor system such that 32 bits of the data string are clocked into each register.

- 5.3.4.4.2 All the shift register outputs are switched between logic '0' and logic '1' at 30 Hz by the TRUE/COMPLEMENT signal applied to each register at pin 1. Shift register outputs loaded with logic '0' from the 96-bit data string change level in phase with the signal at pin 1, while those loaded with logic '1' are in antiphase.

- 5.3.4.4.3 The back plane of the LCD is driven from IC2/36 via R1, while the display segments are driven from the remaining shift register outputs. Those segments driven in antiphase to IC2/36 will darken.

NOTE: The final FACTORY ECAL factor and noise figure stored will be used on all measurements made via the INPUT socket in use. If any measuring head other than that used in this test is to be used in this socket, a fresh FACTORY ECAL must be carried out.

(j) Disconnect the test equipment.

6.5.14 CHECKING MEASURING HEAD GAIN

6.5.14.1 Connect the measuring head to the INPUT socket calibrated for its use. Terminate the head with the matched 50  $\Omega$  load and insert it into the appropriate CALIBRATOR socket.

- (a) Press /RECALL//0//0/.
- (b) Select FRONT or REAR, as appropriate.
- (c) Press /3//0//./1//SHIFT//SF/.
- (d) Check that the 9303 reads 223.6 mV  $\pm$ 1 mV.
- (e) Press /0//SHIFT//SF/.

6.5.15 NOISE CHECKS

6.5.15.1 Test equipment required:

<u>Description</u>	<u>Table 6.8 Item No.</u>
50 $\Omega$ Load	10

Connect the measuring head to the INPUT socket calibrated for its use. Terminate the head with the matched 50  $\Omega$  load and the additional 50  $\Omega$  load.

- 6.5.15.2 (a) Press /RECALL//0//0/. Select FRONT or REAR as appropriate.
- (b) On assembly 19-1014 set switch 1 of switch bank S30 to the closed position (where the slider is towards the switch section number).
- (c) Check that the 9303 indicates less than 200  $\mu$ V.
- (d) Press /WATTS/ and /NULL/. Check that the 9303 indicates 0.000 nW  $\pm$  0.001 nW.
- (e) Remove the 50  $\Omega$  load from the measuring head input port and connect the head to the appropriate CALIBRATOR socket.
- (f) Check that the 9303 indicates 0.000 nW  $\pm$  0.01 nW.
- (g) Disconnect the test equipment. Return switch 1 of switch bank S30 to the open position. Ensure that switch 8 of S30 is set to the closed position.

#### 5.3.4.5 The LED Indicators

5.3.4.5.1 With the exception of the LINE indicator LP1, which lights whenever the +5 V supply is available, the LED indicators are controlled by the shift registers, IC4, IC5 and IC6. An indicator will light when the associated shift register output is held at logic '0'.

5.3.4.5.2 When a change in the indicator pattern is required suitable data strings are generated in the microprocessor system. These enter the assembly at pin 4, and are applied to the data inputs of the three registers in parallel. The clock lines of the shift registers enter the assembly at pins 3, 5, and 6, and carry waveforms, generated in the microprocessor system, which clock the data into the appropriate register.

#### 5.3.5 THE CALIBRATOR SYSTEM

5.3.5.1 The system is carried on assembly 19-1016. It contains two independent calibration sources. These are:

- (a) The internal calibration source, which is used during the automatic internal calibration sequence (ACAL).
- (b) The external calibration source, which provides the signal at the front and rear panel CALIBRATOR sockets used during the measurement of FACTORY ECAL and USER ECAL factors.

The circuit diagram is given in Fig. 11 in Section 7 of this manual.

#### 5.3.5.2 The Internal Calibrator

5.3.5.2.1 The signal provided by the internal calibrator simulates the output of a measuring head. The output waveform consists of bipolar pulses, shaped to match the output of a measuring head, and having an amplitude of 1 V peak-to-peak. The pulse frequency is derived from the sampling system VCO, and so varies between 35 kHz and 70 kHz at a 10 Hz rate. Each output pulse is coincident with the leading edge of one of the 1.5  $\mu$ s drive pulses to the second sampler.

5.3.5.2.2 The trigger pulses for the calibrator are taken from the VCO at IC13b/5, and clock a divide-by-two counter in IC16. The counter output, at IC16/5, is therefore at half the VCO frequency, and has a unity mark/space ratio. When the calibrator is not in use this output is disabled by a logic '0' at IC16/4, which holds IC16a in the set state. This logic level is set by the microprocessor system via the INT CAL SELECT control line.

5.3.5.2.3 The transistors Q17, Q18, Q19 and Q20, with IC17a, form a controlled gain DC amplifier. When the output at IC16/5 is disabled (logic '1') Q17 is switched off, and current flows in Q18, Q20 and R77. When the output from IC16/5 is enabled, Q17 is switched between the on and off states. This in turn, switches Q20 on and off, giving current pulses in R77.

5.3.5.2.4 The current in R77 is stabilised by feedback via R80 to the integrator, IC17a. The output at IC17a/1 varies according to the mean level of the feedback pulses, and controls the current in Q19 and Q18. The mean level at which the current stabilises is set by means of a voltage added to the feedback at IC17a/2. This voltage is adjusted by means of R83.



- (l) Adjust R16 on assembly 19-1016 until the 9303 indicates 1000  $\pm$ 5. Return S2 of switch bank S30 to the open position.
- (m) Set the attenuator to 40 dB. Step the 9303 to the 2  $\mu$ W range and press /STORE//RATIO/.
- (n) Step the 9303 to the 2 mW range and set the attenuator to 10 dB.
- (p) Adjust R4 on assembly 19-1016 until the 9303 indicates 1000  $\pm$ 5.
- (q) Disconnect the test equipment

6.5.13 FINAL ATTENUATOR SETTING

6.5.13.1 Test equipment required:

<u>Description</u>	<u>Table 6.8 Item No.</u>
Signal Generator	4
50 $\Omega$ Load	10

6.5.13.2 Connect the measuring head to the INPUT socket which will be calibrated for its use. Terminate the head with the matched 50  $\Omega$  load and connect it to the signal generator output. Set the signal generator output to a frequency of 500 kHz at a level of 0 dBm  $\pm$ 0.008 dB.

- 6.5.13.3
- (a) Select FRONT or REAR as appropriate.
  - (b) Press /1//0//STORE//SHIFT//AVERAGE/, /VOLTS/ and /7//0//./1//SHIFT//SF/.

NOTE: The 9303 will go through a FACTORY ECAL cycle. The factor measured will be stored.

- (c) Disconnect the measuring head from the signal generator output. Load the measuring head input port with the additional 50  $\Omega$  load.
- (d) Press /7//0//./1//SHIFT//SF/.

NOTE: The 9303 will go through a second FACTORY ECAL cycle. The factor measured in (b) will not be changed, but a new noise figure will be measured and stored.

- (e) Remove the 50  $\Omega$  load from the measuring head input port, and reconnect the measuring head to the signal generator output. Select the manual ranging mode and step through to the 316.2  $\mu$ V range.
- (f) Reset the signal generator output to -57 dBm  $\pm$ 0.01 dB.
- (g) Adjust R118 on assembly 19-1016 until the 9303 indicates 316  $\mu$ V  $\pm$ 1  $\mu$ V.
- (h) Repeat (b) to (g) until no further adjustment of R118 is required.

5.3.5.2.5 The voltage square wave across R77 is shaped (differentiated) by C33/R76, to provide a bipolar waveform similar to that produced by a measuring head. Since the square wave is at half the VCO frequency, and an output pulse is generated by both the leading and trailing pulse edges, the calibrator output is at the VCO frequency.

### 5.3.5.3 External Calibrator

5.3.5.3.1 The external calibrator provides a square wave output at 500 kHz having a true r.m.s. voltage of 223.6 mV when loaded with 50  $\Omega$ . The output of a 1 MHz oscillator in IC15 is divided by two in IC16 to provide a 500 kHz signal of accurate unity mark/space ratio at IC16/8. When the calibrator is not in use this output is inhibited by a logic '0' at IC16/10, which holds IC16b in the set state. This logic level is set by the microprocessor system via the EXT CAL SELECT control line.

5.3.5.3.2 When the output at IC16/8 is enabled it drives the amplifier formed by Q21, Q22, Q23, Q24 and IC17b. This amplifier operates in a similar manner to the one used in the internal calibrator, except that current flows in Q24, and not in Q23, when the calibrator is inhibited. The calibrator output is taken across R91, which provides a 50  $\Omega$  source impedance, and is fed to both CALIBRATOR sockets in parallel. The correct output level is only obtained when the system is loaded with 50  $\Omega$ , so that only one socket may be used at a time.

### 5.3.6 THE GPIB INTERFACE

5.3.6.1 The GPIB interface is carried on assembly 19-1017. The circuit diagram is given in Fig. 13 in Section 7 of this manual.

#### 5.3.6.2 Address Setting and Recognition

5.3.6.2.1 When the interface address is set on the bus by the controller it is recognised by the General Purpose Interface Adaptor (GPIA), IC2, by comparison with the interface address held in an internal address register. The address set on the rear panel switches is read by the microprocessor and written into the GPIA address register every 10 ms.

5.3.6.2.2 The microprocessor sees the address switches as an addressable register within the GPIA. When the GPIA receives the appropriate address it responds by generating an enable signal (ASE) at IC2/4. This enables IC12, putting the logic levels set by the address switches onto the data bus. The microprocessor reads the switch settings from the bus, and then writes the pattern into the GPIA address register.

#### 5.3.6.3 Operation as a Listener

5.3.6.3.1 When the interface is addressed to listen the GPIA conducts the handshake procedure up to the point where the ready for data (RFD) indication is given. At this point IC2/27 is at logic '0', setting the data line buffers in IC3 and IC13 to the receive condition. Data from the bus enters the GPIA data-in register, and an interrupt request is generated by IC2/40 going to logic '0'. This puts IC18/8 to logic '1' and so enables IC9c, which pulls the microprocessor IRQ line to 0 V.

(f) Transfer the thermocouple input to the front panel CALIBRATOR output and note the DVM reading. Ensure that this reading and the final reading obtained in (e) are both within  $\pm 0.1\%$  of the reading obtained in (a).

(g) Press /0//SHIFT//SF/ and disconnect the test equipment.

## 6.5.12 SETTING THE UPPER RANGE ATTENUATORS

### 6.5.12.1 Test equipment required:

<u>Description</u>	<u>Table 6.8 Item No.</u>
Signal Generator	4
Switchable Attenuator	9

6.5.12.2 Connect the measuring head to the INPUT socket which will be calibrated for its use. Terminate the head with the matched  $50 \Omega$  load. Connect the attenuator, set to 0 dB, to the signal generator output. Set the signal generator output to a frequency of 500 kHz at a level which gives +13 dBm at the attenuator output. Connect the measuring head to the attenuator output. Set the attenuator to 30 dB.

- 6.5.12.3
- (a) Press /2//0//./2//SHIFT//SF/ /WATTS/ and /1//0//STORE//SHIFT//AVERAGE/.
  - (b) Select the manual ranging mode, and step the 9303 to the 20  $\mu$ W range. Select FRONT or REAR, as appropriate.
  - (c) Press /STORE//RATIO//RATIO/. This will store the measured value in the RATIO store and put the 9303 to the ratio measurement function. The display will now indicate  $1.000 \pm 0.001$
  - (d) Step the 9303 to the 200  $\mu$ W range, and set the attenuator to 20 dB.
  - (e) Adjust R36 on assembly 19-1016 until the 9303 indicates  $10 \pm 0.05$ .
  - (f) Set the attenuator to 40 dB and step the 9303 to the 2  $\mu$ W range. press /STORE//RATIO/.
  - (g) Step the 9303 to the 200  $\mu$ W range, and set the attenuator to 20 dB.
  - (h) Adjust R26 on assembly 19-1016 until the 9303 indicates  $100 \pm 0.5$ .
  - (j) Set the attenuator to 30 dB. On assembly 19-1014, set switch 2 of switch bank S30 to the closed position (with the slider towards the switch section number). Step the 9303 to the 20  $\mu$ W range and press /STORE//RATIO/.
  - (k) Step the 9303 to the 20 mW range and set the attenuator to 0 dB.

- 5.3.6.3.2 The microprocessor interrupt routine will establish the reason for the interrupt. The GPIA and IC19 are enabled by the  $\overline{GCS}$  signal, and the direction of data transfer through IC19 is set by the R/W signal. The GPIA data-in register is addressed, and the data are transferred to the microprocessor.
- 5.3.6.3.3 When the data transfer is complete the GPIA cancels the interrupt request and allows the data accepted (DAC) line to go high. The handshake routine then continues, and a further data byte, if available, is loaded into the data-in register. The interrupt and data transfer sequence is then repeated.
- 5.3.6.4 Operation as a Talker
- 5.3.6.4.1 When the GPIA is addressed to talk the data-out register will normally be empty. Under these conditions an interrupt request is generated by putting IC2/40 to logic '0'. This output is used to generate an interrupt request for the microprocessor, via IC18, IC14d and IC9c, and to set IC10a.
- 5.3.6.4.2 When IC10a is set a logic '1' is applied to IC11/10. Since IC10b is normally reset, and IC2/27 is at logic '1' when the GPIA is addressed to talk, IC11/9 and 11 are also at logic '1', giving logic '0' at IC11/8. This open circuits the bilateral switches between TP1 and TP2, breaking the RFD line to IC2/18. Even if the listening device asserts that it is ready for data, the GPIA will not attempt to load the contents of the data-out register onto the bus, as IC2/18 is held at logic '0' by the bilateral switch in IC6 which is driven from IC4b.
- 5.3.6.4.3 The microprocessor interrupt routine will establish the reason for the interrupt. The GPIA and IC19 are enabled by the  $\overline{GCS}$  signal, and the direction of data transfer through IC19 is set by the logic level on the R/W line. The GPIA data-out register is addressed and a data byte is written into the register.
- 5.3.6.4.4 Following the data transfer the microprocessor sets data bus line BDO to '0' and addresses IC15, using address lines A0, A1 and A2, so that the microprocessor enable (E) pulse is directed to IC10a/11. This clocks IC10a to the reset condition, giving a logic '0' at IC11/10. The bilateral switches in IC6 reconnect the RFD line to the GPIA, and release IC2/18 from 0 V. When the RFD line puts IC2/18 to logic '1' the GPIA loads the contents of the data-out register onto the bus and continues with the handshake sequence.
- 5.3.6.4.5 If, for any reason, the GPIA is taken out of the talk state part way through a message, the data-out register will be left containing an untransmitted data byte. This situation can arise, for example, if the controller stops the message in order to conduct a serial poll.
- 5.3.6.4.6 When the GPIA is readdressed to talk, either of two requirements may apply. The GPIA may be required to continue with the interrupted message, or may be required to transmit a byte (e.g. the status byte) other than that held in the data-out register. The two situations are distinguished by whether there has, or has not, been a data transfer between the GPIA and the microprocessor since the GPIA left the talk state.

- 6.5.10.3 (a) Set the signal generator output to a frequency of 500 kHz at a level of 1 V  $\pm$ 0.005 V peak-to-peak.
- (b) Adjust the oscilloscope Y channel sensitivities until both channel indications are set to the same level at the greatest convenient amplitude.
- (c) Press /RECALL//0//0/ and /3//0//.//2//SHIFT//SF/.
- (d) Transfer the probe feeding the channel which is providing triggering to monitor IC7/5 on assembly 19-1016. This channel will provide a steady display of the calibrator output, while the other channel will provide an unlocked display of the signal generator output.
- (e) Adjust R83 on assembly 19-1016 until the peak-to-peak amplitudes of the two displayed waveforms are identical.
- (f) Press /0//SHIFT//SF/ and disconnect the test equipment.

#### 6.5.11 SETTING THE EXTERNAL CALIBRATOR

##### 6.5.11.1 Test equipment required:

<u>Description</u>	<u>Table 6.8 Item No.</u>
Digital Voltmeter	2
Signal Generator	4
Thermocouple	11

- 6.5.11.2 Press /3//0//.//1//SHIFT//SF/. Wait 15 minutes for 9303 temperature to stabilise. Connect the DVM to measure the output of the thermocouple. Set the output of the signal generator to a frequency of 500 kHz at a level of 0 dBm  $\pm$ 0.004 dB. Connect the output of the signal generator to the thermocouple input. The following procedure must be completed within a period of 10 mins. During this time the ambient temperature must be maintained between 21°C and 25°C.
- (a) Note the reading on the DVM.
- (b) Transfer the thermocouple input to the front panel CALIBRATOR socket of the 9303.
- (c) Adjust R86 on assembly 19-1016 to obtain the same reading on the DVM as was noted in (a)  $\pm$ 0.1 %.
- (d) Transfer the thermocouple input to the rear panel CALIBRATOR socket and note the DVM reading.
- (e) Adjust R86 until the reading obtained at the rear panel CALIBRATOR socket is the arithmetic mean of the readings obtained in (c) and (d). Note the final reading obtained.

- 5.3.6.4.7 In the latter case IC10a will be in the reset condition, giving a logic '0' at IC10a/9 and a logic '1' at IC11/8. The bilateral switches of IC6 between TP1 and TP2 will be in the conducting condition, so the RFD line to IC2/18 is unbroken. When the GPIA is addressed to talk the byte in the data-out register will be transmitted, followed by the remainder of the interrupted message.
- 5.3.6.4.8 If a data transfer from the GPIA to the microprocessor has occurred since the GPIA left the talk state, IC10a will have been set by the last interrupt request from IC2/40. This will be the situation if, for example, a serial poll is to be conducted, as the serial poll enable (SPE) message byte will have been received and transferred. When the GPIA is addressed to talk, IC2/27 goes to logic '1', and, because IC11/9 and 10 are at logic '1', the RFD line is broken by IC6. When the listener sets the RFD line high IC18/1 is put to logic '1'. Since IC18/2 and 13 are at logic '1' an interrupt request to the microprocessor is generated via IC14d and IC9c. The microprocessor will see this as a demand for fresh data from the GPIA, and will over-write the byte held in the data-out register.
- 5.3.6.4.9 During a serial poll, after transferring the status byte to IC2, the microprocessor addresses IC15 to direct the enable (E) signal to IC10b, clocking it to the set state. If the byte transferred is not the status byte, IC15 is addressed to direct the enable signal to IC10a, clocking it to the reset state. In either case IC11/8 will go to logic '1', the RFD input will be connected by IC6 to IC2/18, and the byte will be transmitted.
- 5.3.6.5 Detection of the Serial Poll Disable Message
- 5.3.6.5.1 When a serial poll sequence has been completed the controller sends the serial poll disable (SPD) message. This is detected by IC8b, c and d and IC1, giving a logic '0' at IC1/8. This returns IC10b to the reset condition, giving a logic '1' at IC11/9 and disconnecting the RFD line from IC2/18 at IC6.

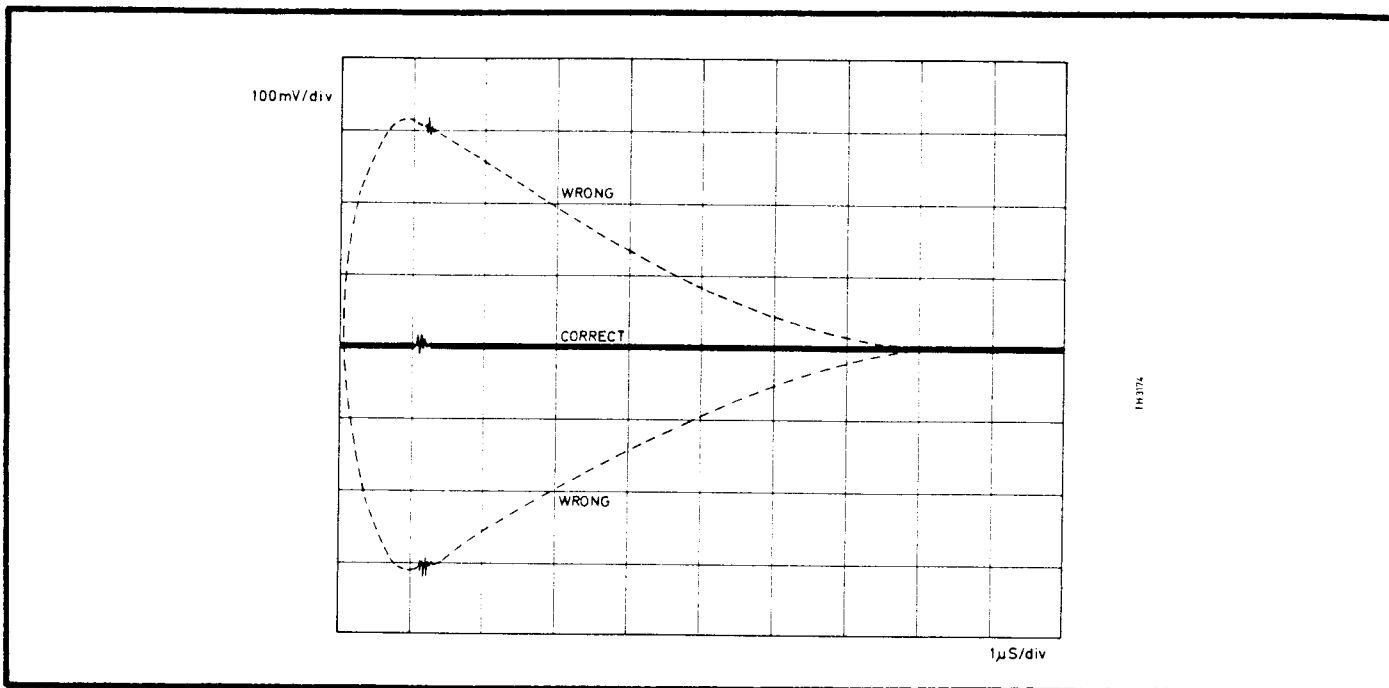

Fig. 6.2 Bias Balance Waveform

6.5.9 SETTING THE SECOND SAMPLER PULSE WIDTH

- 6.5.9.1 Connect the measuring head to the INPUT socket which will be calibrated for its use. Terminate the head with the matched 50 Ω load, and insert it into the appropriate CALIBRATOR socket.
- 6.5.9.2 (a) Select FRONT or REAR as appropriate.
- (b) Press /WATTS/, /METER/ and /AUTO/.
- (c) Press /3//0//./1//SHIFT//SF/.
- (d) Adjust R99 on assembly 19-1016 to obtain the maximum indication possible. The analogue display will be found to be of assistance.
- (e) Press /0//SHIFT//SF/.

6.5.10 SETTING THE INTERNAL CALIBRATOR

6.5.10.1 Test equipment required

<u>Description</u>	<u>Table 6.8 Item No.</u>
Oscilloscope	3
X10 Probe (2)	
Signal Generator	4
50 Ω load	10

- 6.5.10.2 Connect the signal generator output to the 50 Ω load. Connect the probes to the two Y-channel inputs on the oscilloscope, and monitor the signal across the 50 Ω load with both channels of the oscilloscope. Use internal triggering.

APPENDIX 1

ANALYSIS OF RMS MEASURING CIRCUIT

5.A.1.1 The block diagram of the measuring circuit is shown in Fig. 5.7. The voltages  $V_s$  and  $V_n$  represent the signal and noise inputs from the preceding circuit, while  $V_{ox}$  and  $V_{oy}$  are the input offset voltages occurring at the multiplier inputs. The input  $V_c$  is a voltage generated during the auto-zero period and injected into the circuit during the following measurement period.

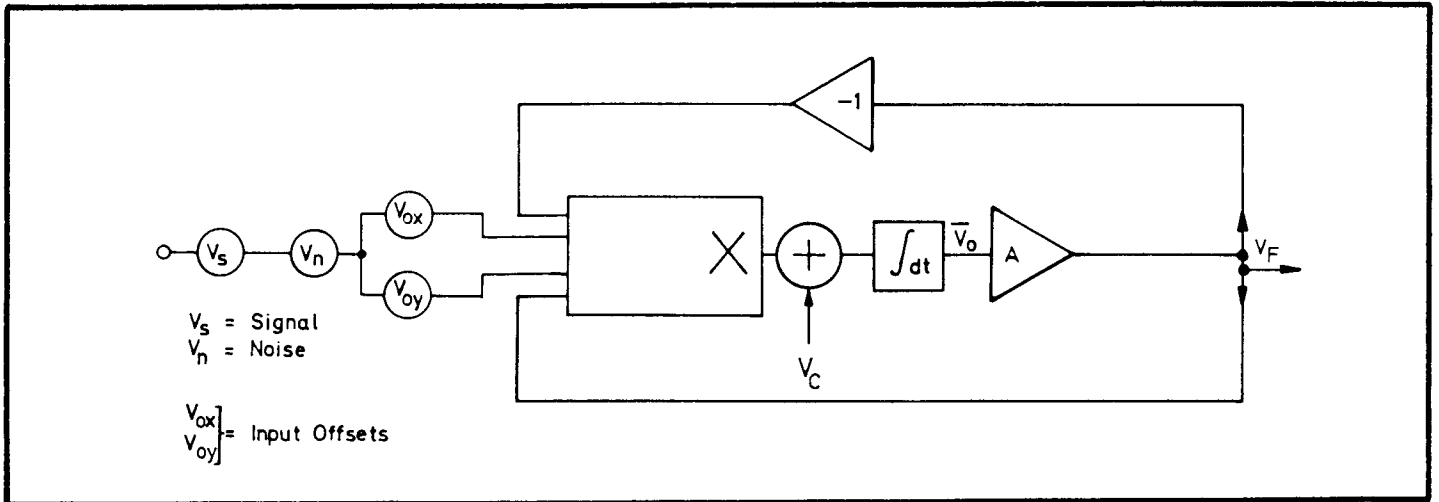

Fig. 5.7 Feedback Loop

5.A.1.2 At the multiplier output:

$$\begin{aligned}
 V_o &= (V_s + V_n + V_{ox} + V_F) (V_s + V_n + V_{oy} - V_F) \\
 &= (V_s + V_n + V_{ox}) (V_s + V_n + V_{oy}) - V_F (V_s + V_n + V_{ox}) + V_F (V_s + V_n + V_{oy}) - V_F^2 \\
 &= (V_s + V_n)^2 + (V_{ox} + V_{oy}) (V_s + V_n) + V_{ox}V_{oy} - V_F (V_{ox} - V_{oy}) - V_F^2 \\
 &= V_s^2 + V_n^2 + 2V_sV_n + V_s (V_{ox} + V_{oy}) + V_n (V_{ox} + V_{oy}) + (V_{ox}V_{oy}) - V_F (V_{ox} - V_{oy}) - V_F^2
 \end{aligned}$$

Since  $V_s$  and  $V_n$  are AC quantities, and so have mean values of zero, at the amplifier input

$$\overline{V_o + V_c} = \overline{V_s^2 + V_n^2 + V_{ox}V_{oy} - V_F (V_{ox} - V_{oy}) - V_F^2 + V_c}$$

But  $V_F = A(V_o + V_c)$ , and if A is large  $\overline{V_o + V_c} = \frac{V_F}{A} = 0$

$$0 = \overline{V_F^2 + V_F (V_{ox} - V_{oy}) - (V_s^2 + V_n^2 + V_{ox}V_{oy} + V_c)}$$



6.5.7 SETTING UP ASSEMBLY 19-1014

6.5.7.1 Test equipment required:

<u>Description</u>	<u>Table 6.8 Item No.</u>
Digital Voltmeter	2
DC Power Supply	12

6.5.7.2 Remove PL15 from assembly 19-1014. Connect the 5 V DC supply between TP2 and 0 V, positive to TP2. Measure the voltage at TP2 with the DVM, and adjust the DC supply to give a voltage of 5 V  $\pm$ 0.5 mV.

- 6.5.7.3
- (a) Switch on the 9303.
  - (b) Press /9//7//.//1//SHIFT//SF/.
  - (c) Adjust R15 until the 9303 indicates 1.000  $\pm$ 0.001.
  - (d) Press /9//7//.//0//SHIFT//SF/. Wait for the ACAL cycle to finish, and check that the 9303 indicates 1.250  $\pm$ 0.001.
  - (e) Adjust the DC supply to give a voltage of 50 mV  $\pm$ 0.15 mV at TP2. Check that the 9303 indicates 0.013  $\pm$ 0.001.
  - (f) Remove the DC supply from TP2. Short circuit TP2 to TP1 and check that the 9303 indicates 0  $\pm$ 0.002. An error indication is normal.
  - (g) Switch the 9303 off. Remove the short circuit between TP2 and TP1 and replace PL15.

6.5.8 SETTING THE MEASURING HEAD BIAS BALANCE

6.5.8.1 Test equipment required:

<u>Description</u>	<u>Table 6.8 Item No.</u>
Oscilloscope	3
X10 Probe	
X1 Probe	

6.5.8.2 Connect the measuring head to the INPUT socket which will be calibrated for its use. Terminate the head with the matched 50  $\Omega$  load. Connect the oscilloscope, via a X1 probe, to monitor TP7 on assembly 19-1016. Use external, negative-edge triggering, taking the trigger signal, via the X10 probe, from TP11 on assembly 19-1016.

- (a) Switch the 9303 on. Select FRONT or REAR, as appropriate.
- (b) Select the manual ranging mode, and the 3.162 V range.
- (c) Adjust R68 on assembly 19-1016 to obtain the best waveform in accordance with Fig. 5.2. Note that there is a delay in circuit response to adjustment of R68.
- (d) Disconnect the test equipment.

5.A.1.3 If the sense of the feedback voltages to the x and y inputs is reversed the last expression becomes

$$0 = V_F^2 - V_F (V_{ox} - V_{oy}) - (V_s^2 + V_n^2 + V_{ox} V_{oy} + V_c)$$

The difference between the two expressions is the sign of the second term. Thus, if the feedback sense is switched at a rate such that the integrator provides adequate averaging, the mean value of this term is zero, and it can be ignored. Such feedback switching thus reduces the effect of the offsets at the multiplier input.

Solving  $0 = V_F^2 - (V_s^2 + V_n^2 + V_{ox} V_{oy} + V_c)$  for  $V_F$  gives

$$V_F = \sqrt{V_s^2 + V_n^2 + V_{ox} V_{oy} + V_c}$$

The required output from the circuit is

$$V_F = \sqrt{V_s^2}$$

so the actual output shows an error of  $\sqrt{V_n^2 + V_{ox} V_{oy} + V_c}$

5.A.1.4 The voltage  $V_c$  is generated in the auto-zero circuit. During auto-zeroing  $V_s$  is made zero, and the residual value of  $V_F$  is integrated. This integral is injected as  $V_c$ , such that the residual value of  $V_F$  is driven to zero. At this point

$$V_c = - (V_n^2 + V_{ox} V_{oy})$$

$V_c$  is maintained during the measurement period, so that the unwanted input to the amplifier due to noise and the multiplier input offsets is cancelled.

TABLE 6.11

Voltage Regulation Test Limits

Voltage Selector Setting	Upper Limit	Lower Limit
240 V	269 V	210 V
220 V	246 V	193 V
120 V	134 V	105 V
100 V	112 V	88 V

6.5.6.8 On assembly 19-1014:

- (a) Transfer the DVM to measure the voltage at TP9 relative to 0 V.
- (b) Turn R25 fully anti-clockwise.

6.5.6.9

- (a) Reduce the variac output to zero, and then increase it to the lower limit given in Table 6.11.
- (b) Turn R25 clockwise until the voltage at TP9 switches to a level less than +0.5 V.
- (c) Reduce the variac output until the voltage at TP9 switches to a level greater than +2.4 V. The variac output must be greater than the voltage given in Table 6.12.

TABLE 6.12

Switching Level

Voltage Selector Setting	Minimum Switching Voltage
240 V	180 V
220 V	165 V
120 V	90 V
100 V	75 V

6.5.6.10

Switch off the 9303 and the supply to the variac. Disconnect the 9303 from the variac. Replace the integrated circuits listed in Table 6.10. Connect the 9303 to the AC supply.

## APPENDIX 2

### OPERATION OF LINEARISED TRANSCONDUCTANCE MULTIPLIER

- 5.A.2.1 A schematic circuit of the multiplier is given in Fig. 5.8. The inputs are the differential current inputs at 1 and 2. It is a property of this circuit that the ratios  $I_P/I_Q$  and  $I_S/I_R$  are equal, and are equal to the ratio of the currents in the linearising networks. (Proof of this property is unnecessary for the purposes of this manual).

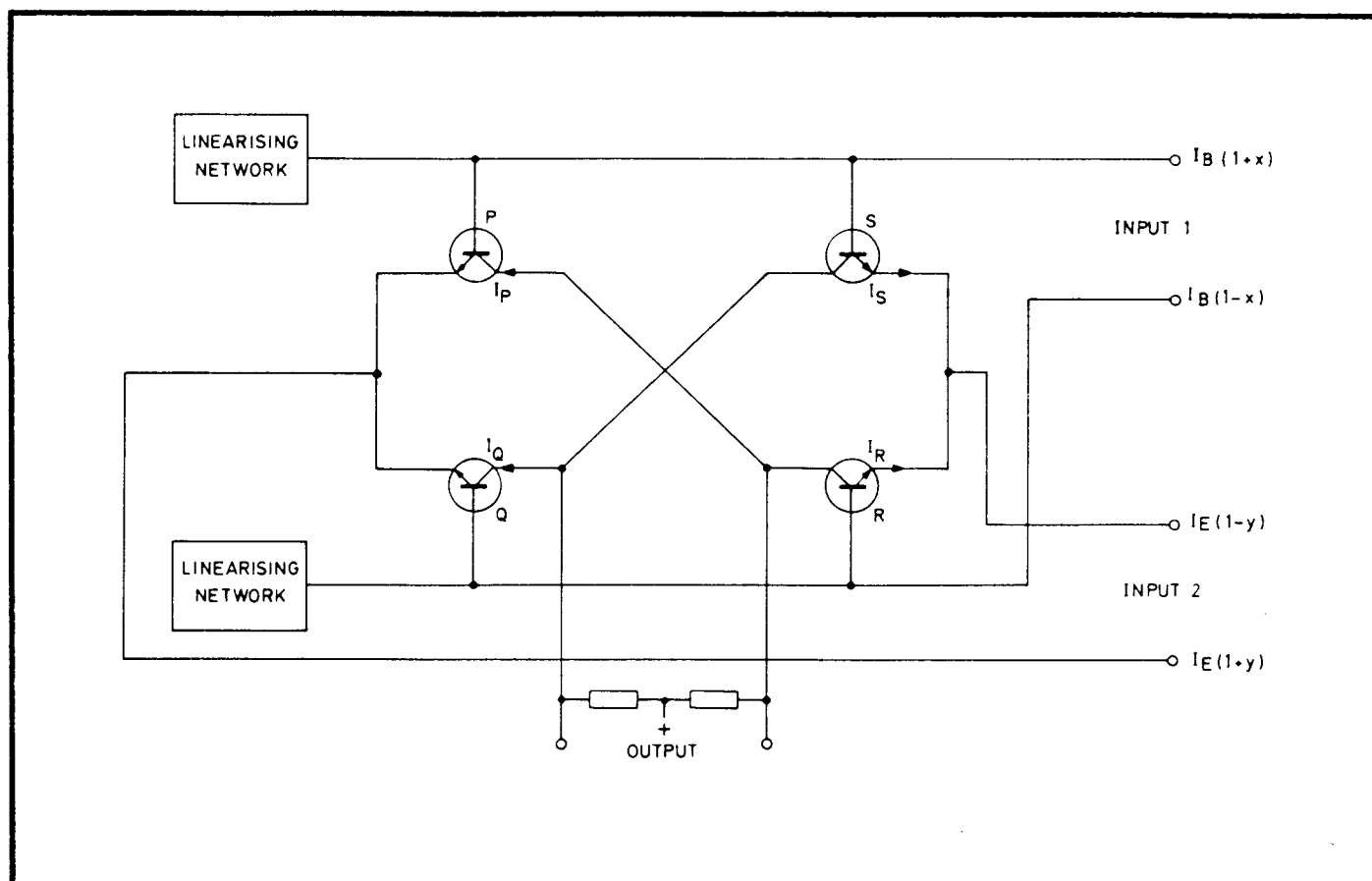

Fig. 5.8 Multiplier Operation

- 5.A.2.2 If the currents at input 1 with zero input signal are both  $I_B$ , then the currents with an applied signal of  $2I_Bx$  will be  $I_B(1+x)$  and  $I_B(1-x)$ . The currents at input 1 form the currents in the linearising networks, and so set the ratios of the collector currents  $I_P/I_Q$  and  $I_S/I_R$  to  $(1+x)(1-x)$ .
- 5.A.2.3 The currents at input 2 with a signal of  $2I_Ey$  will be  $I_E(1+y)$  and  $I_E(1-y)$ . The collector currents of the multiplier transistors will then be:

$$\begin{array}{ll}
 I_P = \frac{1}{2}I_E (1+y)(1+x) & \text{Two currents having a total of } I_E(1+y) \\
 I_Q = \frac{1}{2}I_E (1+y)(1-x) & \text{and a ratio } 1+x/1-x \text{ (equal to the ratio of the} \\
 & \text{linearising networks).}
 \end{array}$$

$$\begin{array}{ll}
 I_S = \frac{1}{2}I_E (1-y)(1+x) & \text{Two currents having a total of } I_E(1-y) \\
 I_R = \frac{1}{2}I_E (1-y)(1-x) & \text{and a ratio of } 1+x/1-x.
 \end{array}$$

6.5.6.5 Set the 9303 LINE switch to OFF. Using the power supply lead, connect the earth pin of the power input plug to a good earth point. Connect the line and neutral pins to the output of the variac. Connect the multimeter to monitor the variac output. Connect the measuring head to the rear panel INPUT socket.

6.5.6.6 (a) Switch on the AC supply to the variac. Adjust the variac to give an output equal to the setting of the supply voltage selector.

(b) Switch on the 9303. Using the DVM, measure the voltage, relative to 0 V, on pin 2 of the front panel INPUT socket (see Fig. 6.1). Adjust R44 on assembly 19-1014 until the measured voltage is between +14.99 V and +15.01 V.

(c) Transfer the DVM to measure the voltage, relative to 0 V, on pin 5 of the front panel INPUT socket. Adjust R49 on assembly 19-1014 until the measured voltage is between -14.99 V and -15.01 V.

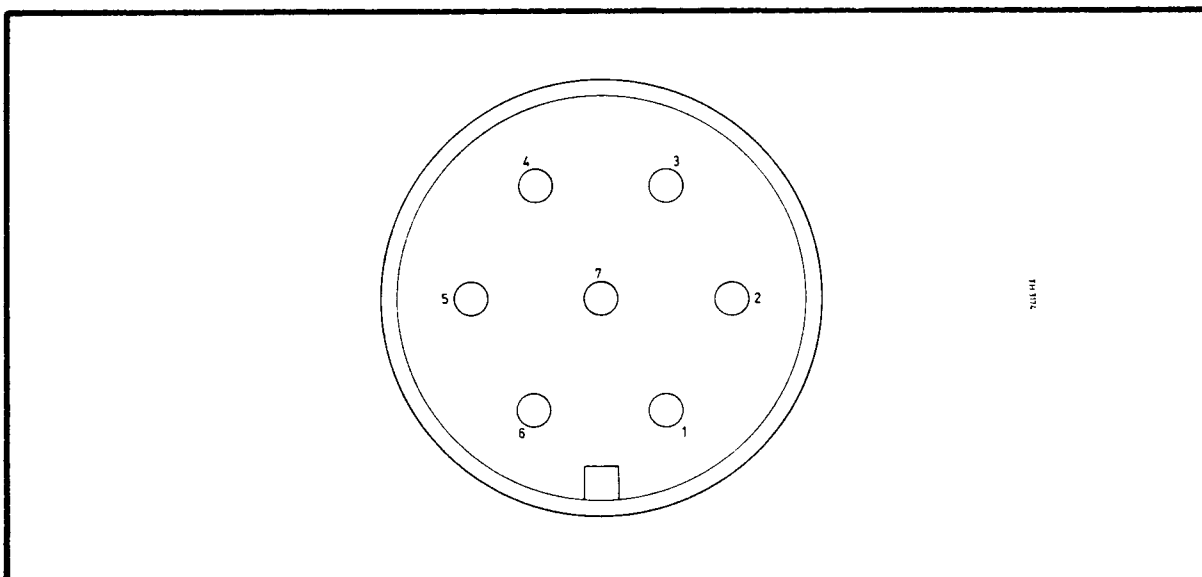

Fig. 6.1 Input Socket  
(Viewed from the front)

(d) Transfer the DVM to measure the voltage at TP3 on assembly 19-1014 relative to 0 V. The voltage must be +5 V  $\pm$ 0.25 V.

(e) Transfer the DVM to measure the voltage at pin 1 of R34. The voltage must be +9.3 V  $\pm$ 1 V.

(f) Transfer the DVM to measure the voltage at TP10. The voltage must be 4.9 V  $\pm$ 0.4 V.

6.5.6.7 Adjust the variac to give an output equal to the upper voltage limit relating to the supply voltage selector setting, as given in Table 6.11. Measure the +15 V, -15 V, +5 V and +9.3 V supplies at the points given in the previous paragraph. Adjust the variac output to the lower voltage limit and repeat the measurements. The voltages must not have changed by more than 100 mV.

5.A.2.4 The multiplier output is the differential current given by

$(I_p + I_R) - (I_Q + I_S)$  and is proportional to

$$\frac{1}{2}I_E (1+y)(1+x) + (1-y)(1-x) - (1+y)(1-x) - (1-y)(1+x)$$

$$= \frac{1}{2}I_E \cdot 4xy$$

$$= \frac{1}{2I_B} \cdot 2I_Bx \cdot 2IEy$$

The differential output current is therefore proportional to the product of the differential input currents.

6.5.6.3 On assembly 19-1014:

- (a) Remove the integrated circuits shown in Table 6.10.

CAUTION: Ensure that the ROMs, IC16, 17, 18 and 19 can be identified to ensure replacement in the correct sockets.

TABLE 6.10

Integrated Circuit Locations

IC Number	Type	Racal-Dana Part Number		
		Build State 1	Build State 2	Build State 3
9	8750			
11	6821			
12	6832			
16	2732	22-8515	22-8540	22-8570
17	2732	22-8514	22-8539	22-8569
18	2732	22-8513	22-8538	22-8568
19	2732	22-8512	22-8537	22-8567
20	6514-9			
21	6514-9			
30	6802			

- (b) Set all sections of the switch bank S30 to the open position (where the slider is furthest from the switch section number).
- (c) Measure the resistance from IC39/3 to ground, with the current source lead of the meter to IC39/3. The resistance must be greater than 30  $\Omega$ .
- (d) Measure the resistance from IC38/3 to ground, with the current source lead of the meter to ground. The resistance must be greater than 30  $\Omega$ .
- (e) Measure the resistance from TP3 to ground, with the current source lead of the meter to TP3. The resistance must be greater than 30  $\Omega$ .

- 6.5.6.4 Check the resistance between the earth pin of the power input plug and the outer ring of the DIN socket on the front panel. The resistance must be less than 1  $\Omega$ .

## 6.1 INTRODUCTION

6.1.1 This section is written in five parts which relate to:

- (a) General maintenance information
- (b) Fault finding procedures for assemblies 19-1014 and 19-1017.
- (c) Signature analysis on assemblies 19-1014 and 19-1017.
- (d) Setting up and calibration procedures.
- (e) Dismantling and reassembly of the 9303.

## 6.2 GENERAL MAINTENANCE INFORMATION

### 6.2.1 REPAIR AND CALIBRATION OF THE MEASURING HEAD

6.2.1.1 Although a circuit diagram, a parts list and a description of the operation of the measuring head are given in this manual, it is not recommended that the customer should attempt to repair or recalibrate this item. For this reason the calibration procedure given in this section includes functional checks of the measuring head only. Where the proper functioning or calibration of a measuring head is doubted, it is recommended that customers should take advantage of the repair and calibration service offered by Racal-Dana Instruments and their agents.

### 6.2.2 BATTERY REPLACEMENT

6.2.2.1 The non-volatile memory is maintained by means of a lithium primary cell, Racal-Dana part number 23-2513, having an expected in-service life of two years. The battery voltage is not an indication of the remaining life, and it is recommended that the cell be changed on a preventive maintenance basis.

6.2.2.2 Whenever possible the battery should be changed with the instrument switched off and disconnected from the AC supply. This will result in corruption of the non-volatile memory contents, and recalibration of the measuring heads (FACTORY ECAL) as described in Section 4, paragraph 4.4 must be carried out. If it is essential that the contents of the non-volatile memory are preserved, it is possible to change the battery with the instrument connected to the AC supply and switched on.



6.5.6 SETTING UP THE POWER SUPPLIES

6.5.6.1 Test equipment required:

<u>Description</u>	<u>Table 6.8 Item No.</u>
Multimeter	1
Digital Voltmeter	2
Variac	13

- 6.5.6.2 (a) Disconnect the power lead from the power input plug.
- (b) Put the LINE switch to ON.
- (c) Set the supply voltage selector to each of the positions shown in Table 6.9 in turn. Measure the resistance between the line and neutral points on the rear of S29 on assembly 19-1014, and ensure that the correct values are obtained. Ensure that the value obtained for the 120 V setting is greater than that obtained for the 100 V setting, and that the value obtained for the 240 V setting is greater than that for the 220 V setting.
- (d) Set the voltage selector to suit the local AC supply. Check that the correct supply fuse for this setting is fitted.

TABLE 6.9

Power Input Resistance

Voltage Selector Setting	Resistance
100 V	6 $\Omega$ - 11 $\Omega$
120 V	6 $\Omega$ - 11 $\Omega$
220 V	24 $\Omega$ - 37 $\Omega$
240 V	26 $\Omega$ - 41 $\Omega$

- WARNING: (1) DANGEROUS AC VOLTAGE LEVELS ARE EXPOSED WHEN THE COVERS ARE REMOVED WITH THE AC SUPPLY CONNECTED.
- (2) BATTERY REPLACEMENT SHOULD ONLY BE CARRIED OUT BY PERSONS SKILLED IN THE REPAIR OF ELECTRONIC EQUIPMENT.
- (3) IF THE BATTERY IS TO BE CHANGED WITH THE INSTRUMENT SWITCHED ON, THE TIP OF THE SOLDERING IRON USED MUST BE ISOLATED FROM EARTH.
- (4) LITHIUM BATTERIES CAN BE DANGEROUS IF WRONGLY TREATED. FOLLOW THE INSTRUCTIONS GIVEN ON THE WARNING PAGE AT THE FRONT OF THIS MANUAL REGARDING THEIR HANDLING AND DISPOSAL.

6.2.2.3 The battery is mounted at the left hand side of the upper surface of the processor board, 19-1014, towards the front of the instrument. Two different types of battery are supplied by Racal-Dana Instruments. These are electrically interchangeable, but are connected to the circuit in different ways. All instruments will accept both types of battery.

6.2.2.4 The procedure for changing the battery is as follows:

- (a) Remove the top and bottom covers from the instrument as instructed in paragraph 6.6.2.
- (b) Cut the tie wrap securing the battery to the processor board. Retain the insulating pad which is held by the tie wrap to the underside of the board.
- (c) Unsolder the NEGATIVE connection of the battery. This is the end of the battery furthest from the front panel of the instrument. It may be secured to pin 22, or to a through hole in the board adjacent to pin 22, according to the battery type.
- (d) Unsolder the POSITIVE connection of the battery. This may be secured to pin 23, or to a through hole in the board adjacent to pin 23.
- (e) Solder the POSITIVE connection of the replacement battery into position.
- (f) Solder the NEGATIVE connection of the replacement battery into position.
- (g) Measure the voltage between pin 22 and ground. The voltage difference must not be more than 10 mV, with pin 22 negative with respect to ground.

IF THIS CONDITION IS NOT MET DISCONNECT THE BATTERY IMMEDIATELY. CHECK THAT THE BATTERY POLARITY IS CORRECT, AND THAT IT IS NOT SHORT CIRCUITED.

TABLE 6.8  
Test Equipment Required for Calibration

Item	Description Recommended Model	Required Parameters
1	Multimeter AVO Model 8	AC Volts: 90 V to 264 V Ohms: 1 $\Omega$ to 41 $\Omega$
2	Digital Voltmeter Racal-Dana Model 4005	DC Volts: 15 V with 10 mV resolution 5 V with 0.1 mV resolution 50 mV with 0.01 mV resolution 2 mV with 1 $\mu$ V resolution
3	Oscilloscope with Qty 2/X10 Probes Qty 1/X1 Probe H.P. 1740A	Bandwidth 100 MHz
4	Signal Generator	Frequency range: 10 kHz to 2 GHz Maximum output: +19 dBm
5	Power Meter H.P. 436A with HP8482A and H.P. 8482H sensors.	VSWR better than 1.05 to 1 GHz
6	Spectrum Analyser	To measure relative powers in the range 15 to 30 dB over the frequency range from 100 MHz to 2 GHz.
7	VSWR Bridge Wiltron Type 60N50 and 60NF50	Type N male and female connections Directivity not less than 46 dB.
8	Fixed Attenuator (2) Radiall Type 414710	10 dB VSWR better than 1.05 to 1 GHz VSWR better than 1.12 from 1 GHz to 2 GHz.
9	Switchable Attenuator	0-90 dB in 1 dB steps Accuracy $\pm 0.01$ dB at 500 kHz
10	50 $\Omega$ Load	Type N female
11	Thermocouple Ballantine 1395A-0.4	Input impedance 50 $\Omega \pm 1\%$ . To accept 0 dBm. Reversal error not more than $\pm 0.1\%$ . Output to be not more than 0.02 dB down at 10 MHz, and not more than 0.5 dB down at 100 MHz, relative to output at DC.
12	DC Power Supply	5 V settable to $\pm 0.5$ mV, and 50 mV, settable to $\pm 0.15$ mV.
13	Variac	To supply 0 V to 264 V from 240 V supply or 0 V to 132 V from 110 V supply at 50 VA.

- (h) When the voltage between pin 22 and ground is correct, secure the battery and the insulating pad to the board using a new tie wrap, Racal-Dana part number 24-0140. The insulating pad must cover the track in the vicinity of the battery on the underside of the board.

6.2.3 SPECIAL FUNCTIONS FOR MAINTENANCE PURPOSES

6.2.3.1 The special functions listed in Table 6.1 are provided for use during maintenance and calibration. They are additional to the special functions for operator use, which are listed in Table 4.1 of Section 4, and are called by pressing

/X//X//.//X//SHIFT//SF/

Where XX.X is the special function number.

TABLE 6.1

Additional Special Functions

Special Function Number	Function
30.0	Cancels 30.2
30.2	Turns on internal calibrator
97.0	Enables and initiates ACAL
97.1	Resets all cal factors
	Selects manual ranging
	Selects 1 V range
	Disables automatic ACALs.
98.0	Cancels 98.1
98.1	Enables all display elements (display check)

## 6.5 CALIBRATION PROCEDURE

WARNING: THIS PROCEDURE REQUIRES THE INSTRUMENT TO BE OPERATED WITH THE COVERS REMOVED. LETHAL VOLTAGE LEVELS ARE EXPOSED UNDER THESE CONDITIONS.

### 6.5.1 INTRODUCTION

6.5.1.1 The procedure given in the following paragraphs provides the means of calibrating the 9303. It is essential that the tests be carried out in the order given, since the results obtained depend, in many cases, on successful completion of previous tests. The procedure should always be followed before returning the 9303 to use after repair. It may also be used as the basis for testing to check the functioning of the instrument.

CAUTION: When the procedure is used to test the functioning of the instrument special function 97.1 must NOT be used, nor should any variable component be adjusted.

### 6.5.2 TEST EQUIPMENT REQUIRED

6.5.2.1 The test equipment required is listed in Table 6.8. A particular model of instrument is recommended in some cases, but other instruments having the required parameters may be used.

### 6.5.3 TEMPERATURE DURING CALIBRATION

6.5.3.1 Throughout the calibration procedure the ambient temperature must be maintained within the range from 18°C to 28°C. During the setting up of the external calibrator circuit the ambient temperature must be maintained between 21°C and 25°C.

### 6.5.4 SIGNAL SOURCE LEVEL SETTING

6.5.4.1 At several points in the procedure instructions are given to set the level of a signal generator output to a prescribed level. Except where other tolerances are given for a specific setting, all settings must be made to a tolerance of ±1%. Additional test equipment, not shown in Table 6.8, may be required to set the level to this degree of accuracy.

### 6.5.5 ADDITIONAL MEASURING HEAD

6.5.5.1 The instructions given are for a 9303 fitted with a single measuring head. If an instrument is to be used with two measuring heads, the setting up of both INPUT sockets and testing of both measuring heads should be carried out at the same point in the procedure. The required accuracy must be achieved for both sockets or measuring heads at each stage before proceeding further. The two CALIBRATOR sockets must NOT both be loaded at any point in the calibration procedure.

## 6.2.4 TEST SWITCHES

6.2.4.1 A bank of eight switches, S30, is mounted on assembly 19-1014. It provides the special facilities shown in Table 6.2 for use during testing and calibration. The function shown in the table is provided when the relevant switch is in the closed position (where the slider is moved in the direction of the arrow moulded on it or towards the switch section number).

TABLE 6.2

Test Switch Functions

Switch Section	Function
1	Inhibits noise cancellation
2	Selects 30 dB attenuator number 2
3	Inhibits all error indications
8	Indicates the GPIB interface is fitted

6.2.4.2 It is essential that switches 1 to 7 are set to the open position and switch 8 is set to the closed position when the 9303 is in use as a measuring instrument.

## 6.3 FAULT FINDING ON ASSEMBLIES 19-1014 AND 19-1017

### 6.3.1 INTRODUCTION

6.3.1.1 The procedure given in the following paragraphs provides a means of fault finding on assemblies 19-1014 and 19-1017, involving the technique of signature analysis. The signatures given are those obtained using the Hewlett-Packard 5004 signature analyser.

### 6.3.2 ASSEMBLY 19-1014

6.3.2.1 Suggested procedures to be followed in the event of certain forms of equipment failure are given in Table 6.3. Where required, signature analysis should be carried out in accordance with the instructions in paragraph 6.4.

### 6.3.3 ASSEMBLY 19-1017

6.3.3.1 Suggested procedures to be followed in the event of malfunction of the GPIB interface are given in Table 6.4. Limited signature analysis can be carried out on assembly 19-1017, as an aid to fault finding, in accordance with the instructions given in paragraph 6.4. No fault finding on assembly 19-1017 should be attempted unless assembly 19-1014 is known to be functioning correctly.

TABLE 6.7

Integrated Circuit Locations

IC Number	Type	Racal-Dana Part Number		
		Build State 1	Build State 2	Build State 3
16	2732	22-8515	22-8540	22-8570
17	2732	22-8514	22-8539	22-8569
18	2732	22-8513	22-8538	22-8568
19	2732	22-8512	22-8537	22-8567

TABLE 6.3

Fault Finding Procedure, Assembly 19-1014

Fault	Procedure
Random LCD elements or LED indicators come on when 9303 is switched on. Keyboard is inoperative.	(a) Check that <del>RESET</del> pulse occurs at IC30/40 when 9303 is switched on. (b) Check that TP9 is at logic '0'. (c) Check address bus signatures at IC16, 17, 18 and 19 sockets. (d) Check data bus signatures. (e) Check the <del>OPE</del> signal signature at IC32/4. (f) Check the display and LED clock signatures at IC32/10, 11, 12, 13, 14 and 15.
All LCD elements on. Keyboard is inoperative.	(a) Check that TP9 is at logic '0'. (b) Check address bus signatures at IC20 and IC21 sockets. (c) If signatures are correct, change IC20 and/or IC21.
Er23, Er24, Er25 or Er26 permanently displayed	(a) Check address bus signatures at IC16, 17, 18 and 19 sockets. (b) If signatures are correct, change IC16, 17, 18 and/or 19.
Display or LED's not operating	(a) Check signatures at IC32/1, 2, 3, 4, 10, 11, 12, 13, 14 and 15. (b) Check for 30 Hz waveform of exact 1:1 mark/space ratio at IC33/10.
Keyboard inoperative or partially operative	(a) Check KEY ENABLE and <del>KEY ENABLE</del> signatures at IC28/19 and IC37/9. (b) Check row scan signal signatures at IC27/8.
Incorrect selection of range, calibrator or measuring head. Incorrect selection of digital output of IC9.	Check signatures at IC34/1, 2, 3, and 4, IC11/23 and IC12/23.



- NOTE: (1) The same ROW SCAN signature is obtained when any key in a row is pressed. A check of every key should be made.
- (2) A signature is obtained at IC27/8 when any key is pressed. Although the probe is applied to a single point, each key row has its own signature.

6.4.3.2 If signature analysis on assembly 19-1017 is required it should be carried out at this stage, before carrying out the data bus analysis on assembly 19-1014. Apply the probe of the analyser to the points given in Table 6.6 and check that the correct signatures are obtained.

TABLE 6.6

System Signatures for Assembly 19-1017

Test Point	Signal Name	Signature
IC14/4	A3	5H20
IC14/6	GPIB ENABLE	PHH1
IC11/6	IC2 SELECT	341A
IC15/15	IC10b CLOCK	053A
IC15/14	IC10a CLOCK	3HA8
IC15/13	IC9a ENABLE	3052
IC15/12	IC7a RESET	0F15
IC15/11	IC9b ENABLE	8304

6.4.3.3 The data bus signatures for assembly 19-1014 depend upon the hardware build state of the instrument and the issue number of the software fitted. For this reason no table of signatures is given. It is essential that the ROMs fitted belong to the same hardware compatible set, that they are of the same issue number, and that they are fitted in the correct positions, as shown in Table 6.7. It should be noted that the part numbers for the ROMs in a set are the same for all software issue numbers, but the issue number is marked on the component body.

6.4.3.4 When the signature analysis is completed, switch off the 9303 and disconnect the analyser. On assembly 19-1014 remove the link from between TP8 and TP4. On switch bank S30, return switch 1 to the open position and set switch 8 to the closed position. Replace the instrument covers.

TABLE 6.4

Fault Finding Procedure, Assembly 19-1017

Fault	Procedure
Instrument will not go into Talk, Listen or Remote.	<ul style="list-style-type: none"> <li>(a) Set the TALK ONLY address switch to logic '1' and check that the TALK annunciator appears in the display. If it does not check that switch 8 of S30 on assembly 19-1014 is closed. Reset the TALK ONLY address switch to logic '0'.</li> <li>(b) Carry out the signature analysis procedure for assembly 19-1017.</li> <li>(c) Set the instrument's address to 00000.</li> <li>(d) Connect a GPIB monitor, set to act as a controller, to the 9303 GPIB connector.</li> <li>(e) Set the DAV message false (high).</li> <li>(f) Set the REN and ATN messages true (low).</li> <li>(g) Check that the 9303 responds and puts NRFD and NDAC true, followed by NRFD false.</li> <li>(h) Set DI08 to DI01 to 00100000, and set DAV true. The 9303 should respond by setting NRFD true. The 9303 should set NDAC false.</li> <li>(j) Set DAV false. The 9303 should respond as in step (g).</li> <li>(k) Set ATN false (high). The 9303 should go to the remote state, and the REMOTE indicator should light.</li> </ul>
<p>In the event of failure at any stage, check that the logic levels at IC2 on assembly 19-1017 are the same as those at the controller.</p>	

TABLE 6.5

System Signatures for Assembly 19-1014

Test Point	Signal Name	Signature
IC29/9	Data Bus	0001
IC29/3, 5, 7, 12, 14, 16 and 18	Data Bus	0000
IC23/9	A0	5555
IC23/12	A1	CCCC
IC23/7	A2	7F7F
IC23/14	A3	5H21
IC23/5	A4	0AFA
IC23/16	A5	UPFH
IC23/3	A6	52F8
IC23/18	A7	HC89
IC23/3	A8	2H70
IC24/14	A9	HPP0
IC24/9	A10	1293
IC24/7	A11	HAP7
IC25/1	A12	3C96
IC25/2	A13	3827
IC16/18	R1	F2A6
IC17/18	R2	PC01
IC18/18	R3	12U3
IC19/18	R4	4POA
TP6	IC26 ENABLE	6H49
IC26/9	IC22/29 ENABLE	H814
IC26/12	KEYBOARD SERVICE ENABLE	HFP6
IC36/12	KEYBOARD SERVICE ENABLE	HFP7
IC37/8	ROW 1 SCAN	6F34
IC37/6	ROW 2 SCAN	495C
IC37/11	ROW 3 SCAN	AP72
IC37/3	ROW 4 SCAN	U45A
IC27/8	ROW 1 SCAN	6F35
	ROW 2 SCAN	495A
	ROW 3 SCAN	AP73
	ROW 4 SCAN	U45C
IC26/11	OPE	47F9
IC32/15	} SERIAL DATA CLOCKS	HFU5
IC32/14		C73F
IC32/13		PHFP
IC32/12		3C72
IC32/11		FPHH
IC32/10		C3C6
IC26/4	RAM ENABLE	A8C1
IC26/10	IC34 ENABLE	86F3
IC34/15	IC12 ENABLE	OP84
IC34/14	IC11 ENABLE	UFUA
IC34/12	GPIB ENABLE	PHHO

TABLE 6.4 (Continued)

Fault Finding Procedure, Assembly 19-1017

Fault	Procedure
Instrument will go to listen but not remote.	<p>(a) Carry out steps (a) to (g) as instructed above.</p> <p>(b) Set DIO8 to DIO1 to 0100000 and set DAV true. The 9303 should respond by setting NRFD true and NDAC false.</p> <p>(c) Set NRFD false and NDAC true by means of the GPIB monitor.</p> <p>(d) Set ATN false. The 9303 should respond by setting DAV true.</p>
<p>In the event of failure at any stage, check that the logic levels at IC2 on assembly 19-1017 are the same as those at the controller. If failure occurs at step (d) check the functioning of the interrupt circuitry.</p>	
Instrument sends incorrect data when talking.	<p>Check data bus lines and bus transceivers on assembly 19-1017 to ensure both logic levels are possible.</p>

## 6.4 SIGNATURE ANALYSIS

### 6.4.1 PREPARATION FOR SIGNATURE ANALYSIS

6.4.1.1 Switch off the instrument and disconnect the AC supply. Remove the covers, as instructed in paragraph 6.6.2, and carry out the following operations on assembly 19-1014:

- (a) Remove ICs 11, 12, 20 and 21
- (b) Short circuit TP8 to TP4
- (c) Set switch 1 on switchbank S30 to the closed position (where the slider is towards the switch section number). Set the remaining switches of S30 to the open position.

6.4.1.2 If analysis is to be carried out on assembly 19-1017, IC2 on that assembly must be removed in addition to the operations given in paragraph 6.4.1.1.

### 6.4.2 CONNECTION OF THE SIGNATURE ANALYSER

6.4.2.1 Connect the signature analyser as follows:

- (a) CLOCK input to TP5, negative edge trigger.
- (b) START and STOP to IC25/3, positive edge trigger.
- (c) GROUND to TP4.

### 6.4.3 ANALYSIS PROCEDURE

WARNING: THIS PROCEDURE REQUIRES THE INSTRUMENT TO BE OPERATED WITH THE COVERS REMOVED. LETHAL VOLTAGE LEVELS ARE EXPOSED UNDER THESE CONDITIONS.

6.4.3.1 Connect the 9303 to the AC supply and switch the instrument on. Apply the probe of the analyser to the points given in Table 6.5, and check that the correct signatures are obtained.